

TM 1-4920-451-13&P

TECHNICAL MANUAL

OPERATOR'S AND INTERMEDIATE
MAINTENANCE MANUAL INCLUDING
REPAIR PARTS AND SPECIAL TOOLS LIST

FOR

SHOP SET, ROTOR, AIRMOBILE

PIN

4920-99-CL-A84

NSN

4920-00-405-9270

"Approved for public release; distribution is unlimited."

HEADQUARTERS, DEPARTMENT OF THE ARMY
1 May 1991

CHANGE
NO. 1

HEADQUARTERS
DEPARTMENT OF THE ARMY
WASHINGTON, D.C., 29 JANUARY 1993

OPERATOR'S AND INTERMEDIATE
MAINTENANCE MANUAL INCLUDING
REPAIR PARTS AND SPECIAL TOOLS LIST
FOR
SHOP SET, ROTOR, AIRMOBILE

P/N
4920-99-CL-A84

NSN
4920-00-405-9270

DISTRIBUTION STATEMENT A: Approved for public release; distribution is unlimited.

TM 1-4920-451-13&P, 1 May 1991, is changed as follows:

1. Remove and insert pages as indicated below. New or changed text material is indicated by a vertical bar in the margin. An illustration change is indicated by a miniature pointing hand.

Remove pages

Insert pages

3-27 through 3-30

3-27 through 3-30

2. Retain this sheet in front of manual for reference purposes.

By Order of the Secretary of the Army:

GORDON R. SULLIVAN
General, United States Army
Chief of Staff

Official:

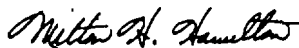

MILTON H. HAMILTON
Administrative Assistant to the
Secretary of the Army
03379

DISTRIBUTION:

To be distributed in accordance with DA Form 12-31-E, block no. 3148, requirements for TM 1-4920-451-13&P.

WARNING
PRECAUTIONARY DATA

Personnel performing operations, procedures and practices which are included or implied in this Technical Manual shall observe the following warnings. Failure to observe these warnings and precautionary information can cause serious injury, death, or destruction of materiel.

WARNING

An operating procedure, practice, etc., which, if not correctly followed, could result in injury or loss of life.

CAUTION

An operating procedure, practice, etc., which, if not strictly observed, could result in damage or destruction of equipment.

NOTE

An operating procedure, condition, etc., which is essential to highlight.

WARNING

When all equipment and materiel is stored on the stationary side of the shelter, the limited floor space presents an obstacle to operating personnel. This is most critical during the raising and lowering of the roof panel. Failure to observe supplemental expansion instructions could result in personnel inside the shelter becoming trapped between the roof panel and equipment. Serious injury to personnel could result.

WARNING

The fold-out floor counterbalance cables must be secured at the cable housings prior to aligning the shelter hinged floor. If the counterbalance cables are not secured, the counterbalance cables will remain under tension. DO NOT attempt to remove cables if the counterbalance cables are not secured. Removing cables while under tension could cause serious injury to personnel.

WARNING

HIGH VOLTAGE exists in the electrical system of the shop. All electrical inspections, repairs or replacement will be performed with the power off and only by qualified electricians. Serious shock hazards exist which could result in injury or death to personnel.

WARNING

Four personnel are needed when moving or lifting the Environmental Control Unit (ECU). Unit weighs approximately 290 pounds. Trying to move or lift an ECU without sufficient help can cause serious injury to personnel.

WARNING

Cabinets are extremely heavy when fully equipped. At least two personnel are required to lift or move. Attempting to lift or move cabinet without sufficient personnel can result in severe injury.

WARNING

Methylethylketone (MEK), used to clean replacement inserts, is flammable and toxic. Use only in well ventilated areas. Breathing vapors can cause headaches and nausea. Repeated contact with skin can cause irritation. If irritation persists see a doctor. If in contact with eyes, wash immediately with water for 15 minutes and seek medical attention.

Safety goggles will be worn when drilling and cleaning holes for insert replacement. Flying chips can cause eye injury or blindness.

WARNING

High pressure compressed air against skin or near eye can cause injury or blindness. Do not direct compressed air against skin or near eyes. Always wear safety goggles when working with compressed air.

WARNING

Extreme care must be taken while performing all types of welding operations. Serious health and fire hazards exist. Harmful light rays can cause eye injury or blindness. Protective face masks and goggles must be used as well as other special clothing to reduce risks. Poisonous fumes, burns, electric shock, fire and explosion hazards are some of the additional possibilities of injury associated with welding operations. It is essential that all safe practices be strictly observed.

CAUTION

Shop utilizes 3-PHASE Electric Current. Proper phasing must be achieved when wiring the Power Distribution Panel to power source. Improper phasing can result in damage to the ECUs and other electrically operated equipment.

CAUTION

Care must be taken to ensure that proper hardware is used to secure equipment for transport. Lack of correct hardware could cause extensive damage to equipment or the shelter when shop is moved.

CAUTION

Torque values must be observed to prevent possible damage to equipment or the shelter, Improper procedures could result in extensive damage to government property. See App. G.

TECHNICAL MANUAL
No. 1-4920-451-13&P

HEADQUARTERS
DEPARTMENT OF THE ARMY
WASHINGTON, D.C., 1 May 1991

OPERATOR'S AND INTERMEDIATE
MAINTENANCE MANUAL INCLUDING
REPAIR PARTS AND SPECIAL TOOLS LIST FOR

S H O P S E T , R O T O R , A I R M O B I L E

REPORTING ERRORS AND RECOMMENDING IMPROVEMENTS

You can help improve this manual. If you find any mistakes or if you know of any way to improve the procedures, please let us know. Mail your letter, DA Form 2028 (Recommended Changes to Publications and Blank Forms), or DA Form 2028-2 located in the back of this manual direct to: Commander, US Army Aviation Systems Command ATTN: AMSAV-MC, 4300 Goodfellow Blvd., St. Louis, MO 63120-1798. A reply will be furnished directly to you.

		Page
CHAPTER 1.	INTRODUCTION	1-1
SECTION I.	General Information	1-1
SECTION II.	Equipment Description and Data.	1-1
SECTION III.	Principles of Operation	1-4
CHAPTER 2.	OPERATOR INSTRUCTIONS	2-1
SECTION I.	Initial Shop Expansion	2-1
SECTION II.	Preparing Shop For Operation	2-5
SECTION III.	Preparing Shop For Shipment or Storage	2-19
CHAPTER 3	MAINTENANCE INSTRUCTIONS	3-1
SECTION I.	Repair Parts, Special Tools, TMDE and Support Equipment	3-1
SECTION II.	Service Upon Receipt	3-1
SECTION III.	Maintenance Procedures	3-2
APPENDIX A	REFERENCES	A-1
APPENDIX B	MAINTENANCE ALLOCATION CHART	B-1
SECTION I.	Introduction	B-1
SECTION II	Maintenance Allocation Chart	B-4
SECTION III	Tool and Test Equipment	B-6
SECTION IV	Remarks	B-6

APPENDIX C	COMPONENTS OF END ITEM AND BASIC ISSUE ITEMS LIST	C-1
SECTION I.	C-1
SECTION II.	Components of End Item.....	C-1
SECTION III.	Basic Issue Items (BI)	C-2
APPENDIX D	REPAIR PARTS AND SPECIAL TOOLS LIST	D-1
SECTION I.	Introduction	D-1
SECTION II.	Repair Parts list	D-7
	Functional Group Numbers	
	01 Fasteners	D-7
	02 Fixtures	D-9
	03 Electrical	D-15
	04 Special Brackets and Fabricated Components	D-16
	05 Floor Plug Inserts	D-23
	99 Bulk	D-24
SECTION III.	Special Tools List	D-25
SECTION IV.	National Stock Number (NSN) and Part Number (P/N) Index	D-25
APPENDIX E	EXPENDABLE/DURABLE SUPPLIES AND MATERIALS LIST	E-1
APPENDIX F	ILLUSTRATED LIST OF MANUFACTURED ITEMS	F-1
APPENDIX G	TORQUE LIMITS	G-1
ALPHABETIC INDEX	INDEX 1

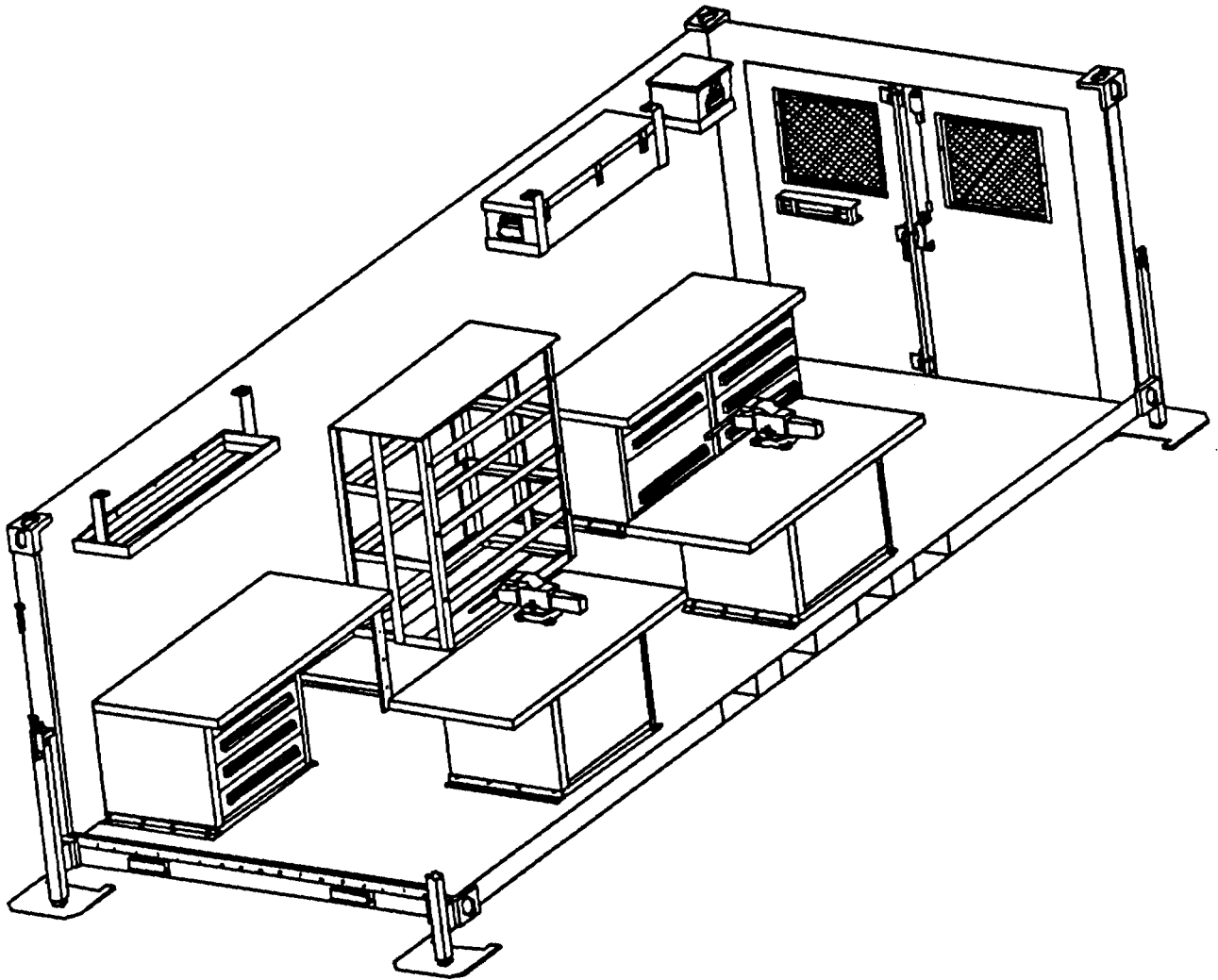

CHAPTER 1 INTRODUCTION

SECTION I. GENERAL INFORMATION

1-1. scope.

Type of Manual: Operator and Intermediate Maintenance

Equipment Name: Rotor Shop

Purpose of Equipment: To provide rotor repair and maintenance support for divisional aviation units. This shop is utilized in conjunction with other maintenance shops in the AVIM support unit.

1-2. Maintenance Forms, Records and Reports.

Department of the Army forms and records used to maintain this equipment will be those prescribed by DA PAM 738-751, The Army Maintenance Management System - Aviation (TAMMS-A).

1-3. Reporting Equipment Improvement Recommendations (EIR).

If your Rotor Shop needs improvement, let us know. Send us an EIR. You, the user, are the only one who can tell us what you don't like about your equipment. Let us know why you don't like the design. Put it on an SF 368 (Quality Deficiency Report). Mail it to: Commander, US Army Aviation Systems Command, ATTN: AMSAV-QRF, 4300 Goodfellow Blvd., St. Louis, MO 63120-1798. We will send you a reply.

1-4. Destruction of Army Materiel to Prevent Enemy Use.

Procedure for destroying Army materiel to prevent enemy use are listed in TM 750-244-1-4, Procedures for Destruction of Aviation Ground Support Equipment (FSC 4920), to Prevent Enemy Use.

1-5. Preparation for Storage or Shipment.

For general technical information on preparation for storage and shipment refer to TM 55-1500-204-25/1 and TM 743-2001. For specific information to prepare the shop for storage or shipment refer to paragraph 2-12.

SECTION II. EQUIPMENT DESCRIPTION AND DATA

1-6. Characteristics, Capabilities and Features.

a. Characteristics.

- (1) Provides work area for Rotor Shop to perform its maintenance function.
- (2) Provides rotor repair and maintenance support for the AVIM unit.
- (3) Housed in a tactical, one side expandable, shelter (NSN 5411-01-124-1377).

b. Capabilities and Features.

(1) Transportable by highway, rail, marine or air (C-130, C-141 or C-5 aircraft, Army CH-47 and CH-54 helicopter).

(2) Can be operated in any geographic area under any climatic condition.

(3) Can be stored/transported and operated out of the same ISO shelter.

1-7. Location and Description of Major Components.

a. Equipment Location in Transport/Storage Mode (Shelter Closed).

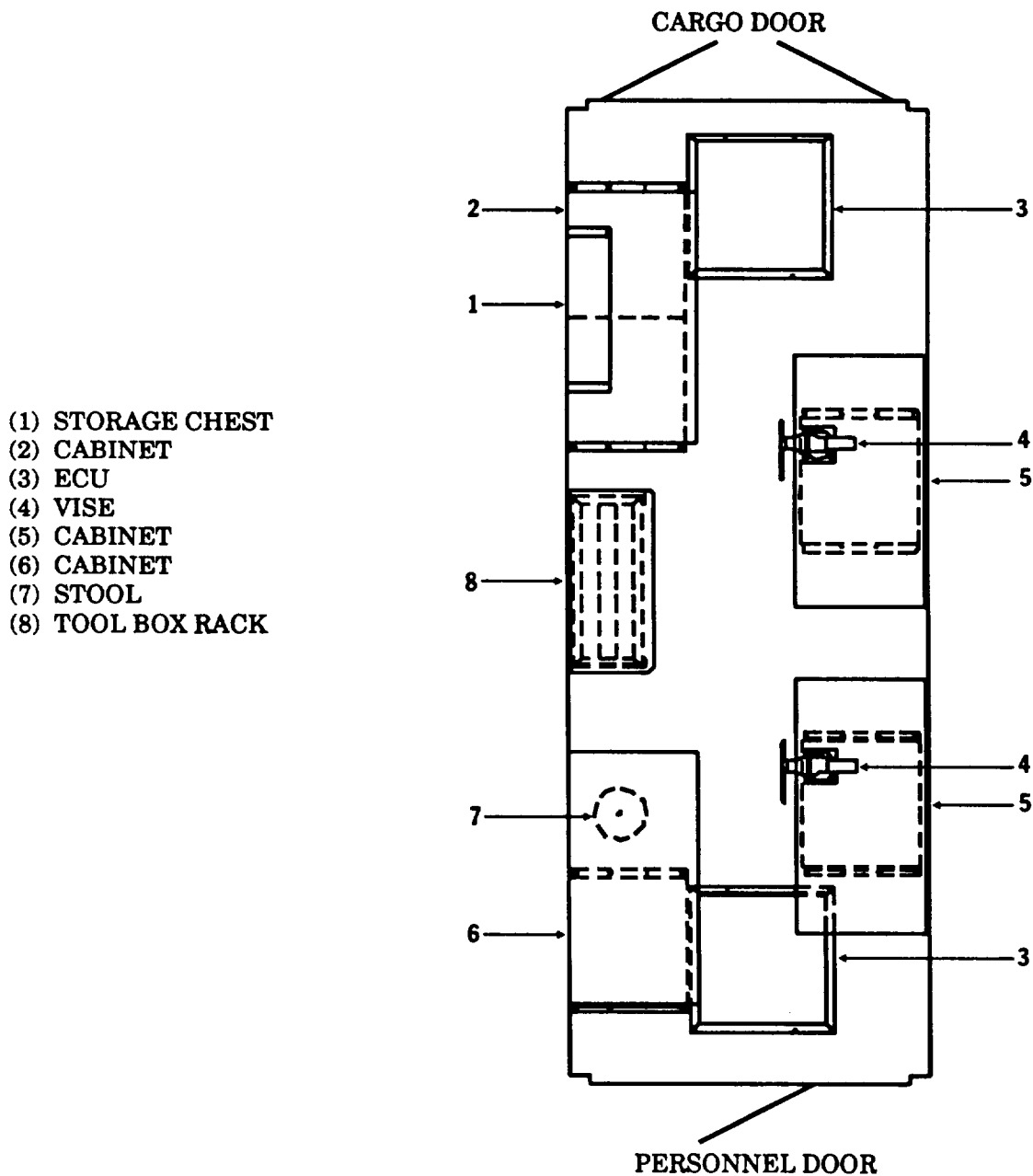

1-7. Location and Description of Major Components -Continued.

b. Recommended Equipment Location in Operational Mode (Shelter Expanded).

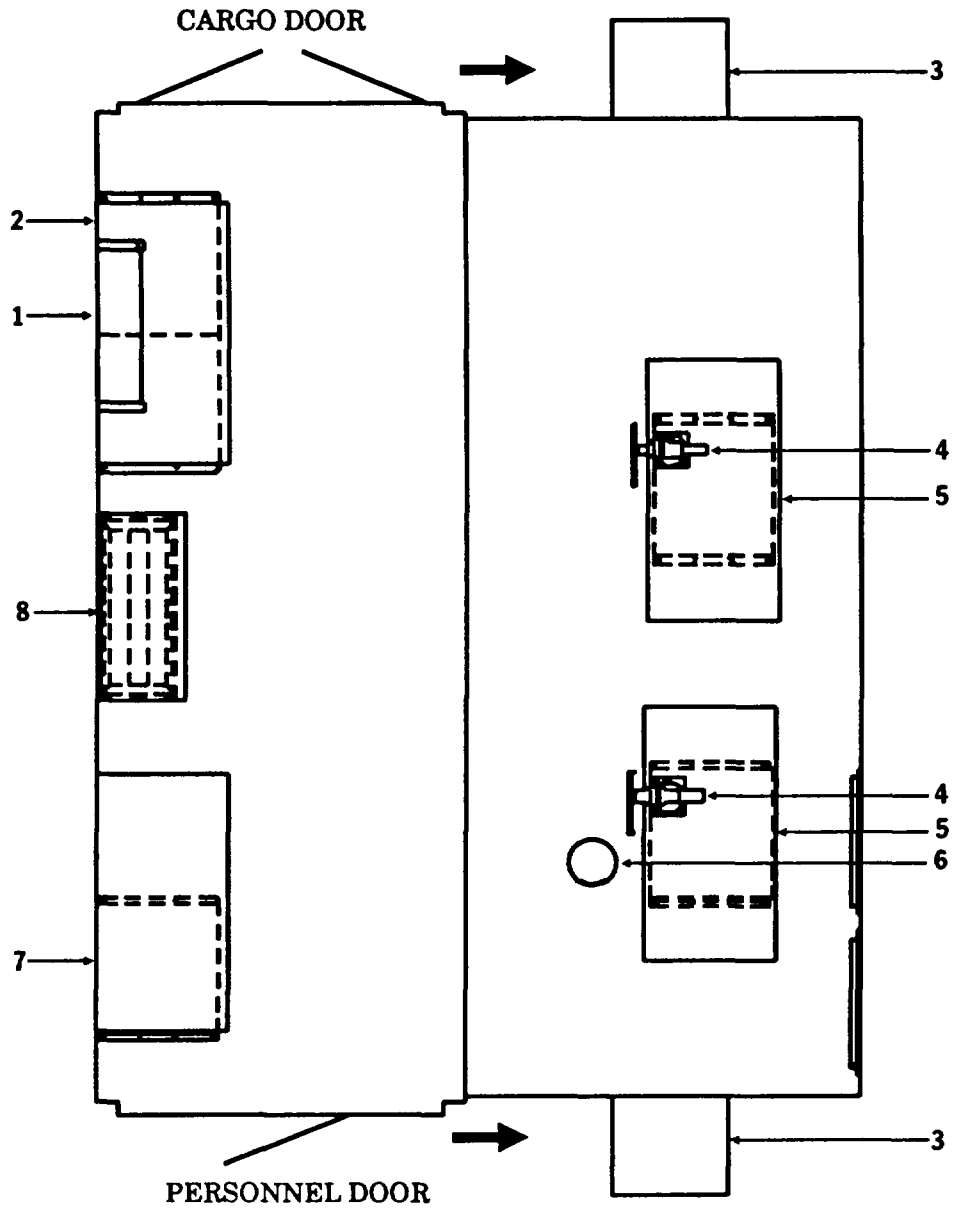

- (1) STORAGE CHEST
- (2) CABINET
- (3) ECU
- (4) VISE

- (5) CABINET
- (6) STOOL
- (7) CABINET
- (8) TOOL BOX RACK

SECTION III. PRINCIPLES OF OPERATION

1-8. After the shelter has been expanded, the operator will unbolt selected items of equipment. These items will be moved to recommended positions on the expanded side of the shelter (see para., 1-7b). The selected items, when moved, will not be secured (bolted) in place. This allows the shop personnel a certain flexibility in the event long or bulky material must be repaired within the shelter. The recommended locations were selected for proper utilization of floor space and maximum safety for the operating personnel.

1-9. Detailed instructions for unbolting equipment and the recommended sequence for movement are contained in Chapter 2, Section II. Supplemental procedures for opening and closing the shelter are contained in Chapter 2, Sections I and III. TM 10-5411-201-14 is required for detailed instructions.

1-10. Electrical power to operate the Rotor Shop is provided by a generator or a commercial power source. A power distribution panel (PDP) is used between the power source and the power entry panel of the shelter. Overload protection is provided by circuit breakers.

CHAPTER 2 OPERATOR INSTRUCTIONS

SECTION I. INITIAL SHOP EXPANSION

2-1. Placement of Rotor Shop. The Rotor Shop should be located with power cable length, tactical deployment, exhaust/inlet of ECUs and phasing between related shops kept in mind. The shop's power entry panel, next to the personnel entrance door, should be facing toward the power source and power distribution panel.

2-2. Shelter Expansion

a. Remove shop storage chest, located on fixed sidewall near ceiling at cargo entrance door, from mounting bracket for easy access to hardware and tools.

b. Observe shelter expansion instructions in TM 10-5411-201-14 until two handles of solar bar are extended and hinged roof is slid outward. Continue shelter expansion observing supplemental expansion instructions found below.

c. Supplemental Expansion Instructions.

WARNING

When all equipment and materiel is stored on the stationary side of the shelter, the limited floor space presents an obstacle to operating personnel. This is most critical during the raising and lowering of the roof panel. Failure to observe supplemental expansion instructions could result in personnel inside the shelter becoming trapped between the roof panel and equipment. Serious injury to personnel could result.

1. Two personnel, outside the shelter, must lift the roof panel (1) far enough to allow two people inside to release the support struts (2), extend them to full length and insert quick-release pins (3).

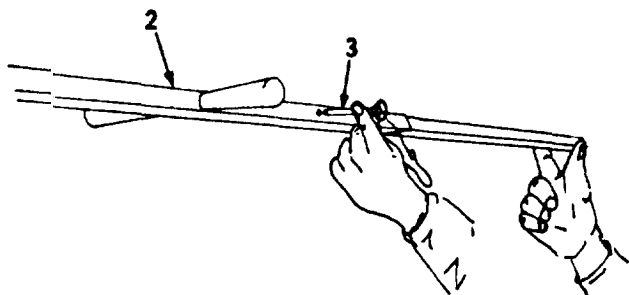
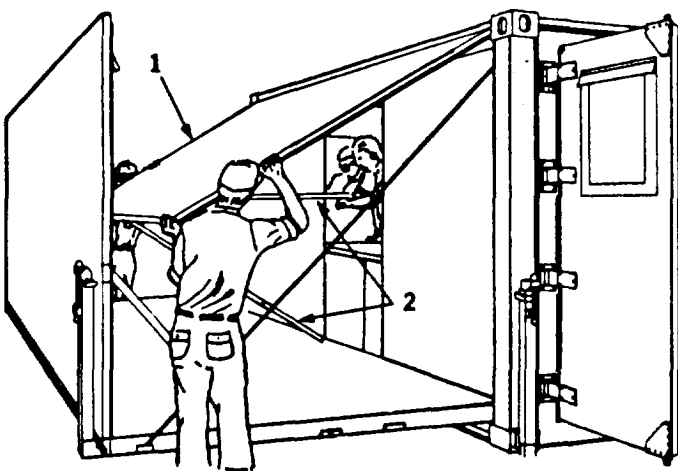

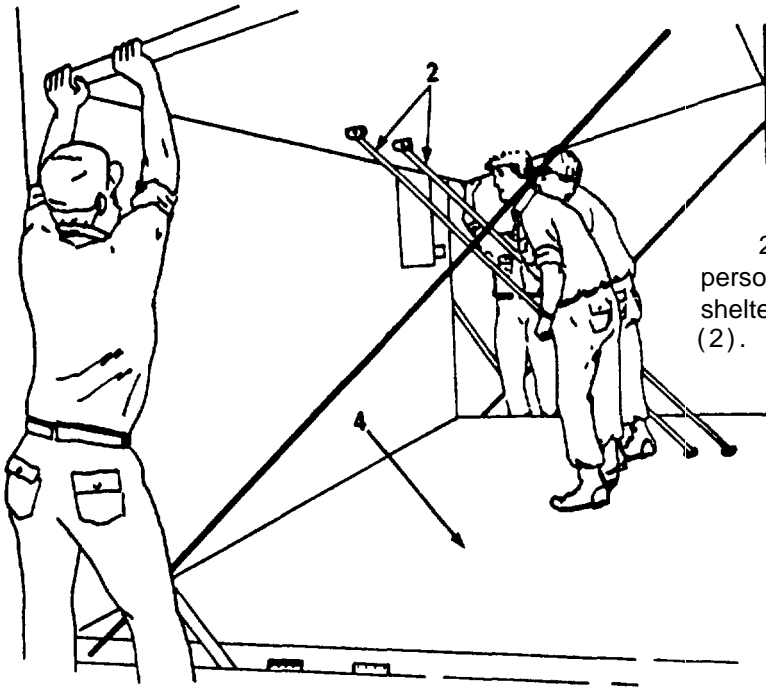

2. As soon as there is enough floor area (4), the personnel inside will move to the expanded side of the shelter raising the roof with extended support struts (2).

3. Once the struts (2) are totally supporting the roof panel (1), the end walls (5) are swung to the open position.

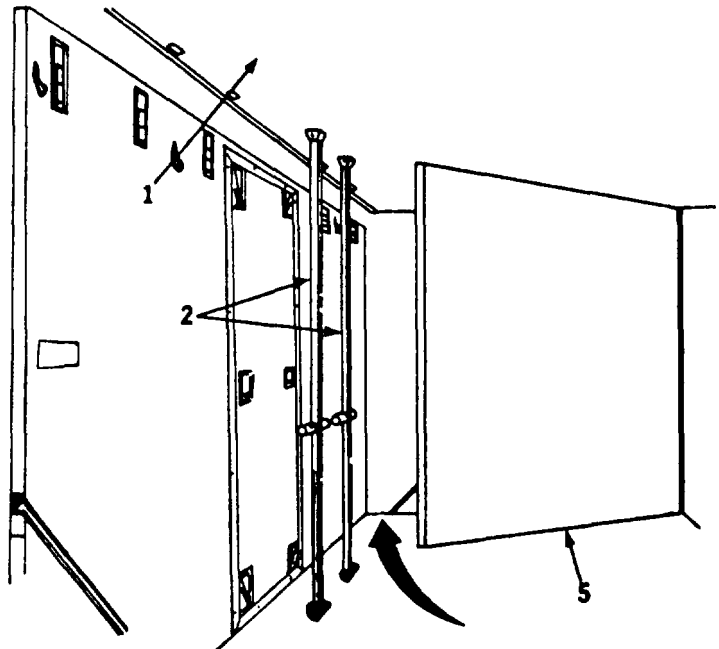

WARNING

The fold-out floor counterbalance cables must be secured at the cable housings prior to aligning the shelter hinged floor. If the counterbalance cables are not secured, the counterbalance cables will remain under tension. DO NOT attempt to remove cables if the counterbalance cables are not secured. Removing cables while under tension could cause serious injury to personnel.

NOTE

It may be necessary to further lower the fold-out floor to expose the cable stop balls in order to engage the slide stops.

4. Ensure slide (6) are closed against counterbalance cable stop balls (7) on cable reels (8) at each end of shelter.

5. Continue with remaining expansion procedures outlined in TM 10-5411-201-14 for final expansion of the shelter.

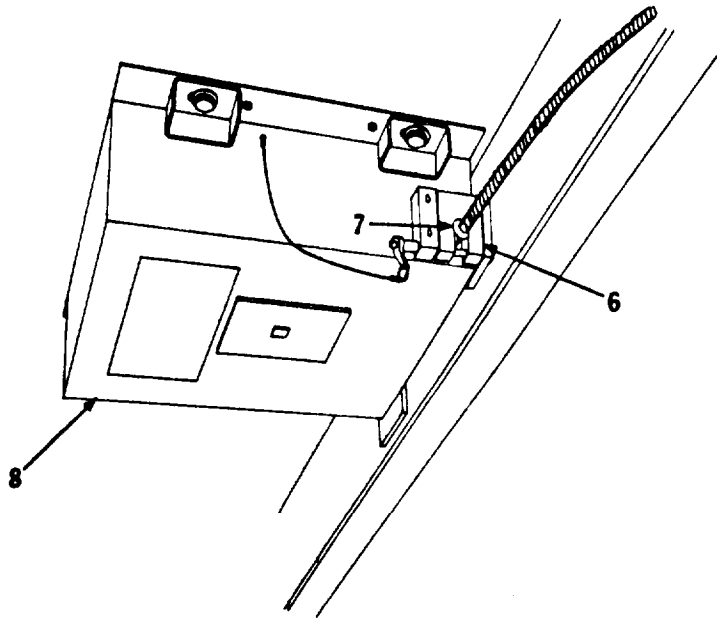

d. Removing Counterbalance Cables.

1. After shop erection is complete (AND COUNTERBALANCE CABLES ARE SECURED), remove three screws (1) from cable retainer block (2).

2. Let cable (3) and retainer block (2) hang loose next to shelter.

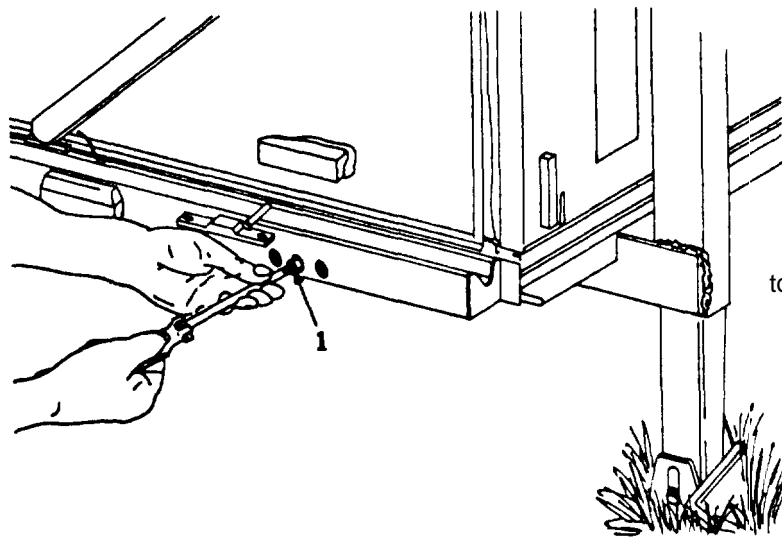
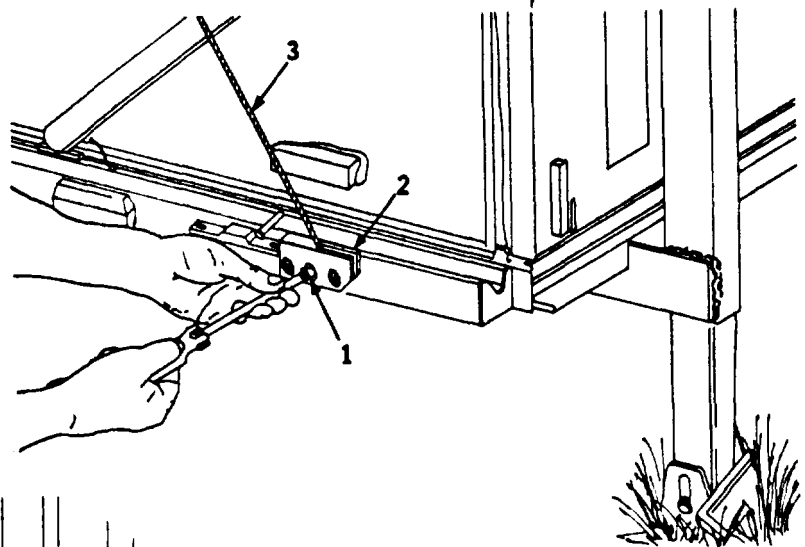
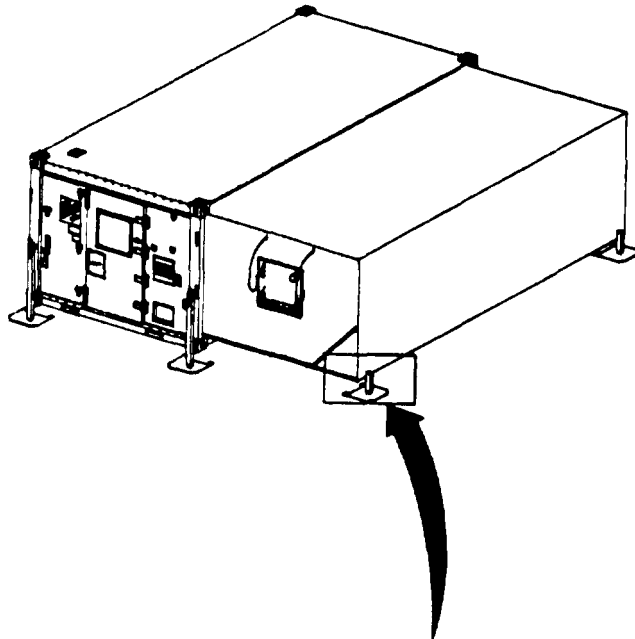

3. Install retainer block screws (1) and secure.

4. Repeat 1,2, and 3 above for remaining cable.

e. Shop is now ready for positioning of equipment to operational mode.

SECTION II. PREPARING SHOP FOR OPERATION

2-3. Electric Power.

a. External Grounding of Shop.

1. Remove ground rod assembly from shop.
2. Install external ground IAW TM 10-5411-201-14 and TC 11-6.

WARNING

HIGH VOLTAGE exists in the electrical system of the shop. All electrical inspections, repairs or replacement will be performed with the power off and only by qualified electricians. Serious shock hazards exist which could result in injury or death to personnel.

CAUTION

Shop utilizes 3-PHASE Electric Current. Proper phasing must be achieved when wiring the Power Distribution Panel to power source. Improper phasing can result in damage to the ECUs and other electrically operated equipment.

b. Connection Power Distribution Panel to Power Source. A qualified electrician will connect power distribution panel power cable to power source IAW TM 5-6150-226-13&P, and set power distribution power panel main circuit breaker to ON and individual breakers OFF.

c. Connection Shelter Power er Cable Two 100-foot cables provided may be connected or used individually.

1. **Remove power cable(s) (1) from shop.**

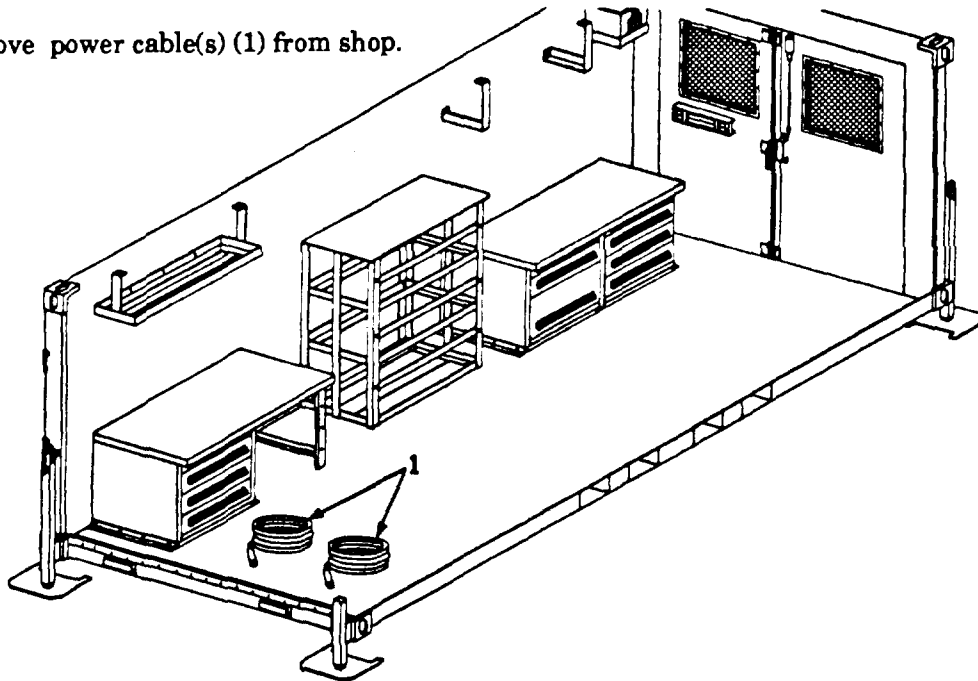

2. Ensure main circuit breaker (2) in breaker panel (3) is set to OFF position before connecting power cable.

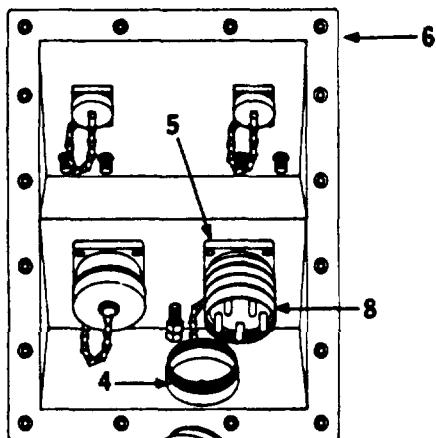
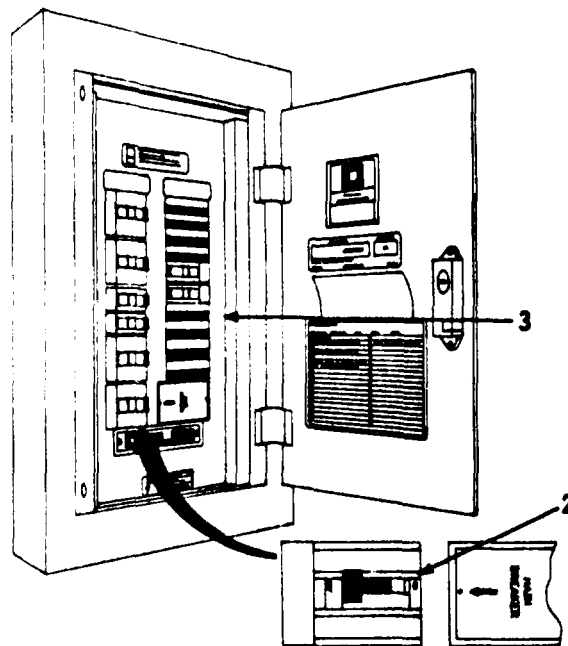

3. Remove dust cap (4) from J1 Service Entrance receptacle (5) on power entry panel (6).

4. Insert cable female connector (7) firmly into receptacle (5) and secure with lock ring (8).

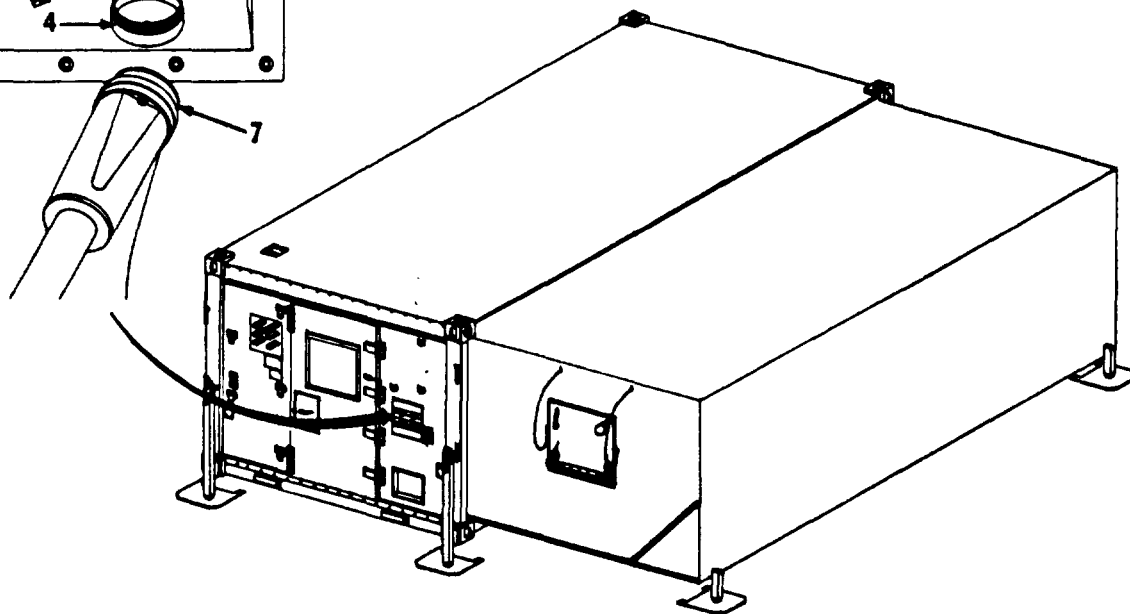

CAUTION

Ensure that the power cable is not twisted, kinked or laid over sharp objects.

5. Extend power cable(s) (1) between shop (9) and power distribution panel (10).

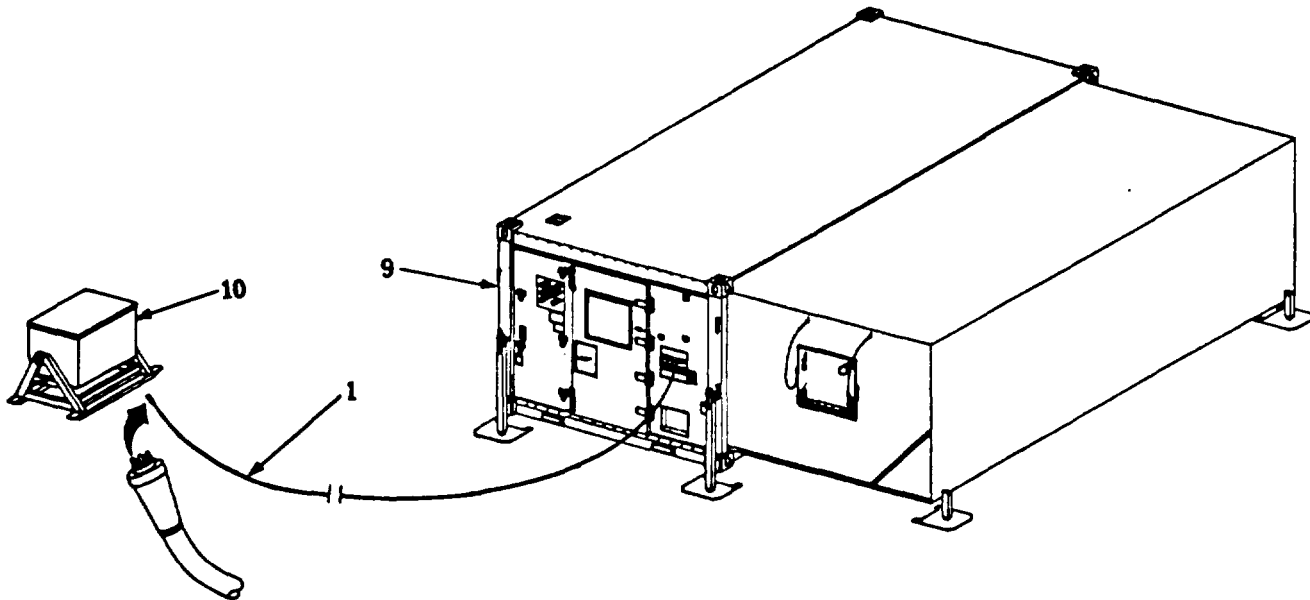

d. Connecting Shelter Power Cable to Power Distribution Panel.

1. Ensure corresponding shelter's power cable outlet circuit breaker (1) in power distribution panel (2) is set to OFF position.
2. Connect the shelter power cable (3) to power distribution panel (2).
3. Set corresponding shelter's power cable outlet circuit breaker (1) to ON position.

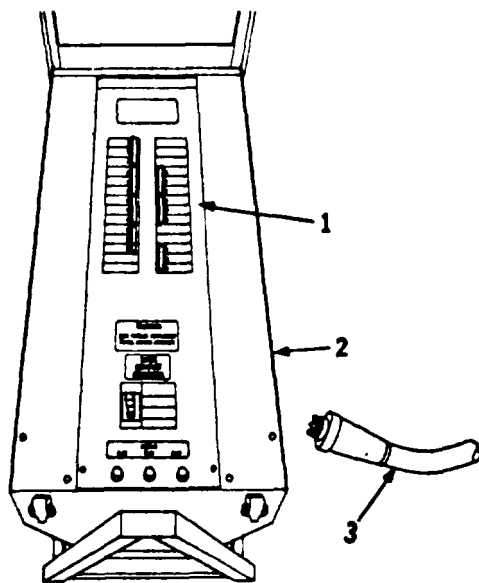

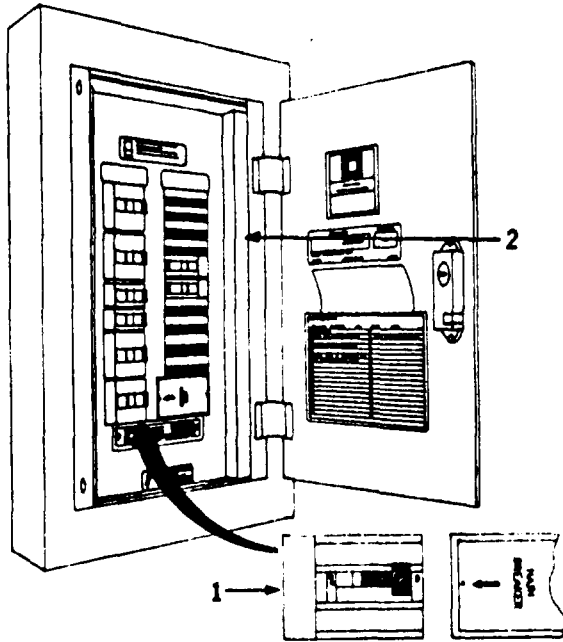

e. Power On at Shelter.

1. Ensure all circuit breakers are in the OFF position.
2. Set main circuit breaker (1) in the shelter breaker panel (2) to ON position.
3. Set selected circuit breakers to ON position.

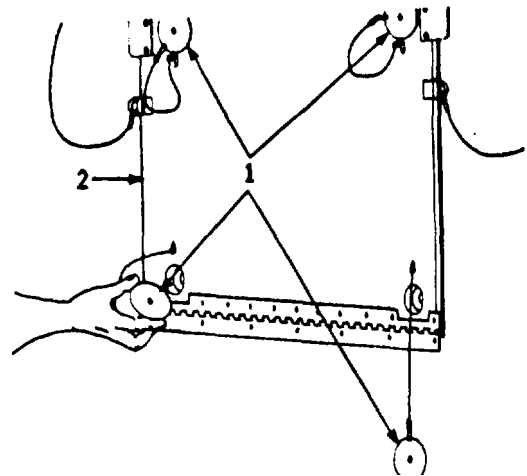

2-4 Positioning Shop Equipment for Operation.

a. Positioning ECUs for Operation.

1. Remove four plugs (1) on outside of shelf (2).

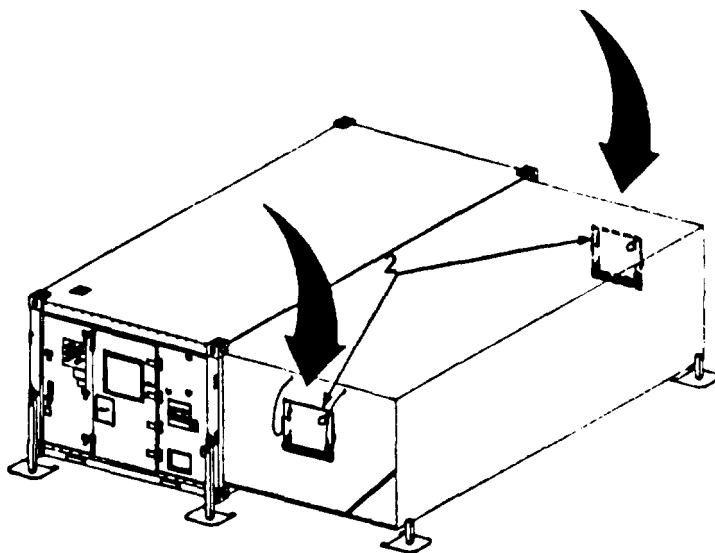

2. From inside shelter, loosen two latch bolts (3) on shelf (2). Turn latches (4) to release fold-down shelf (2).

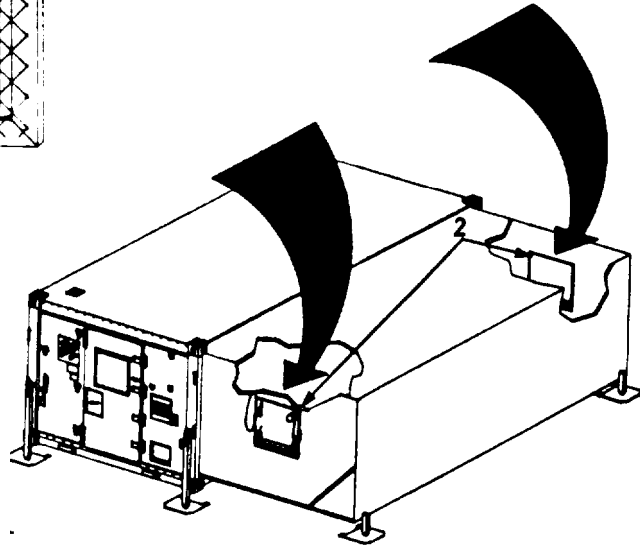
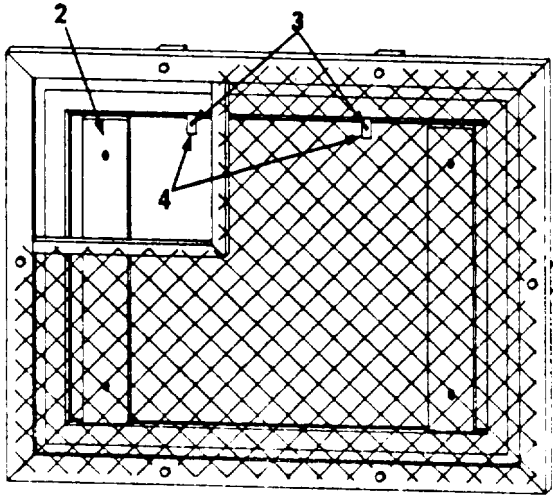

3. Lower shelf (2) to the limit of the support cables (5).

4. Obtain one ECU seal (6) from storage chest and insert at frame bottom (7).

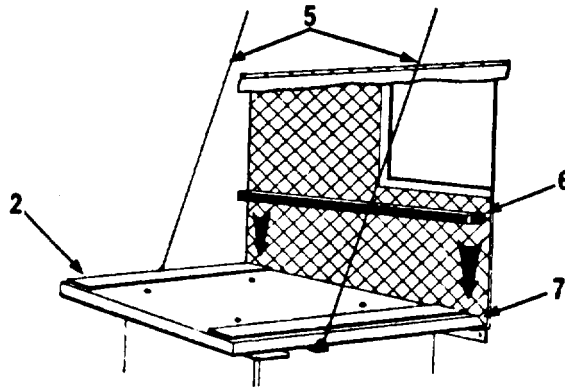

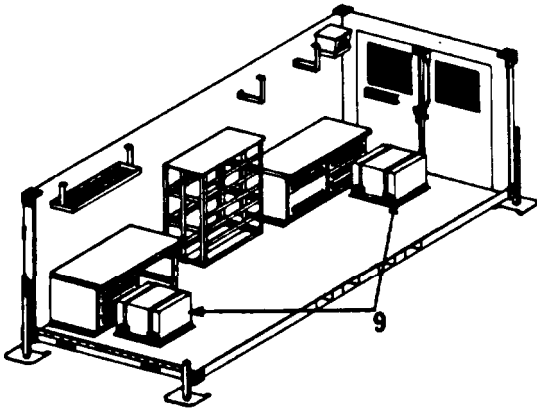

5. Loosen cargo straps (8) on ECU (9), release from ring bolts (10) and remove.

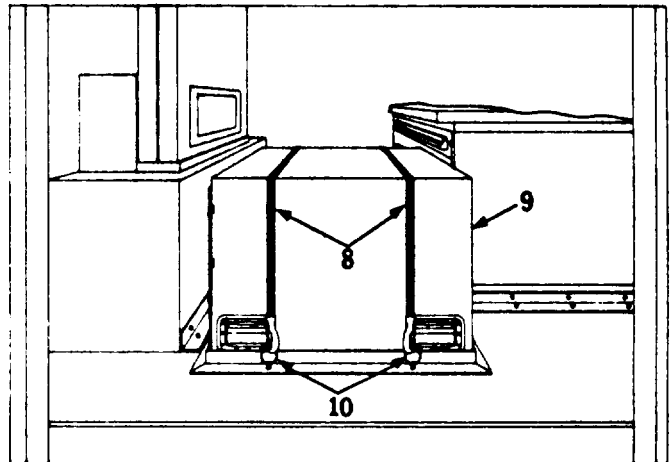

WARNING

Four personnel are needed when moving or lifting the Environmental Control Unit (ECU). Unit weighs approximately 290 pounds. Trying to move or lift an ECU without sufficient help can cause serious injury to personnel.

6. Use lift handles (11) to raise ECU (9), from the floor frame (12).

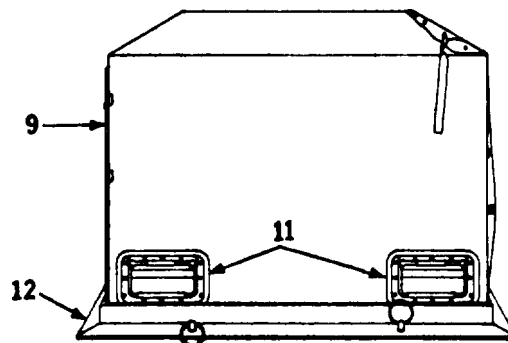

7. Carry ECU (9) outside and position near end wall shelf (2).

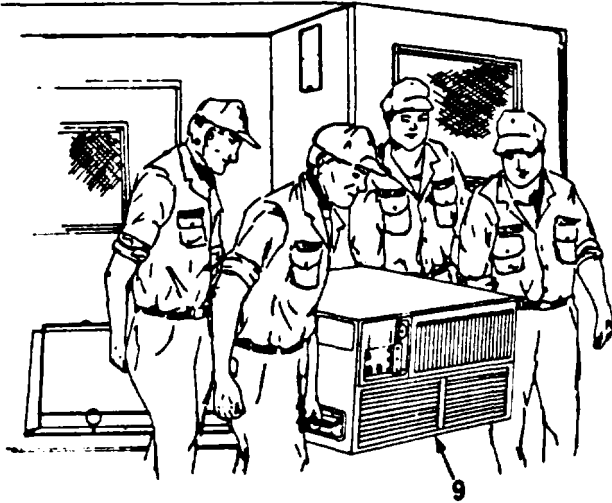

8. Lift ECU (9) onto fold-down shelf (2) with control panel (13) facing toward inside of shop.

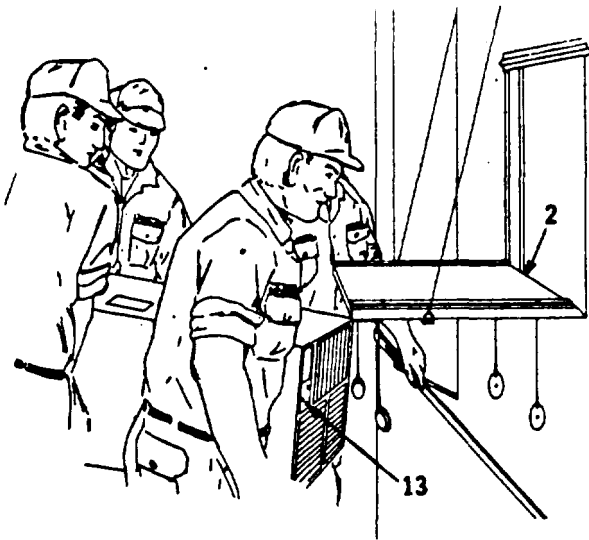
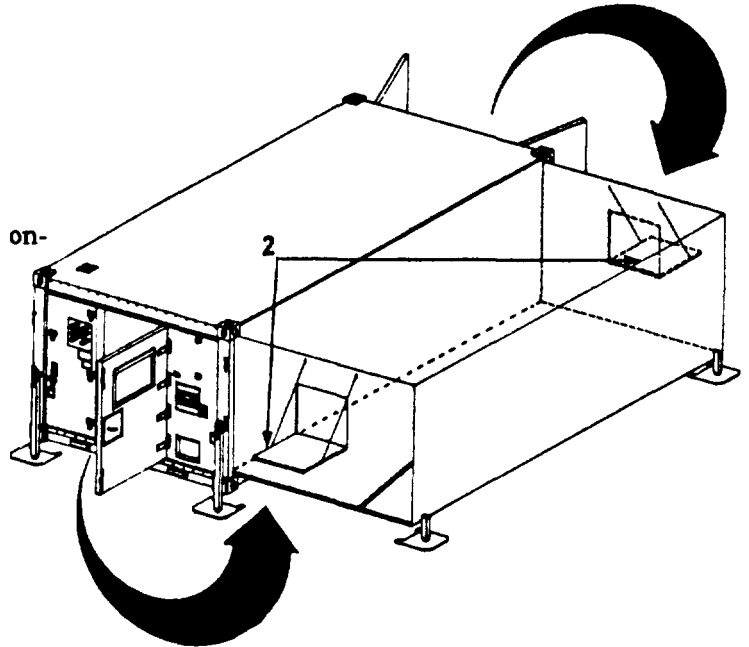

9. Slide ECU (9) forward between support cables (5).

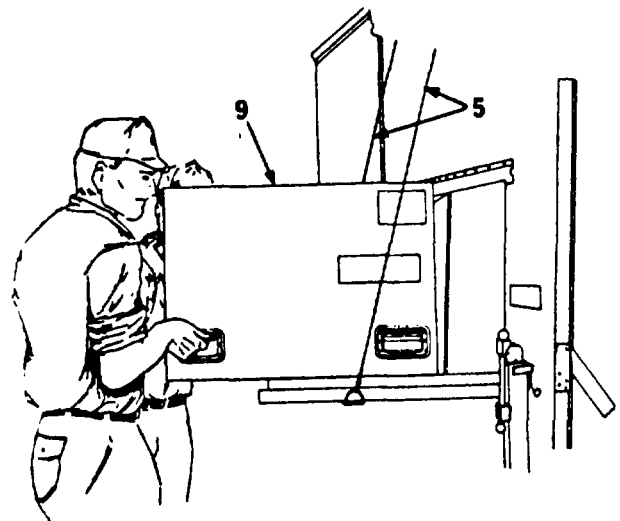

10. Aline bolt holes (14) in base of ECU with holes (15) in shelf (2).

11. Obtain ECU mounting hardware from shop storage chest and install IAW TM 5-4120-384-14.

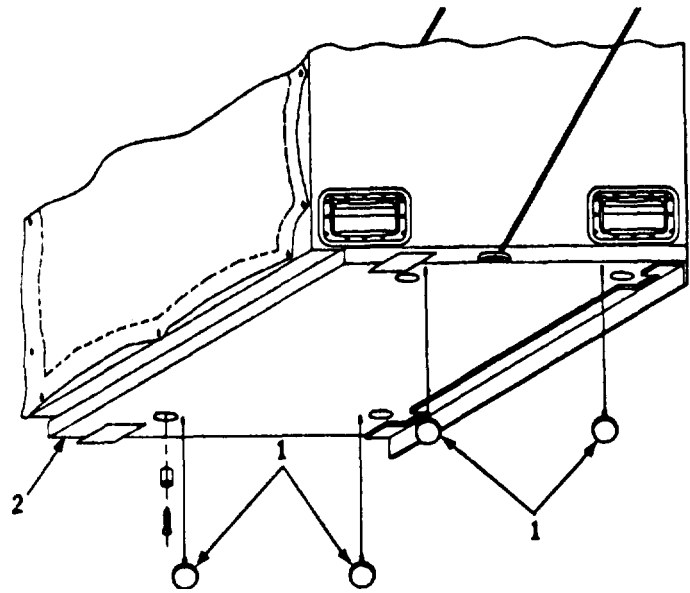
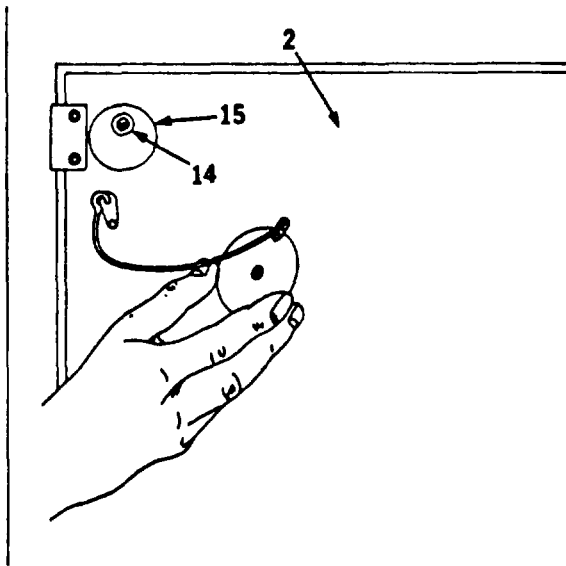

12. Install four plugs (1) in shelf (2).

NOTE

Proper fit between ECU and surrounding seal is essential to maintain light discipline.

13. Check seal (16) around ECU (9) for proper fit and alinement. It may be necessary to temporarily remove the ECU Security Screen (17) to properly aline ECU seal.

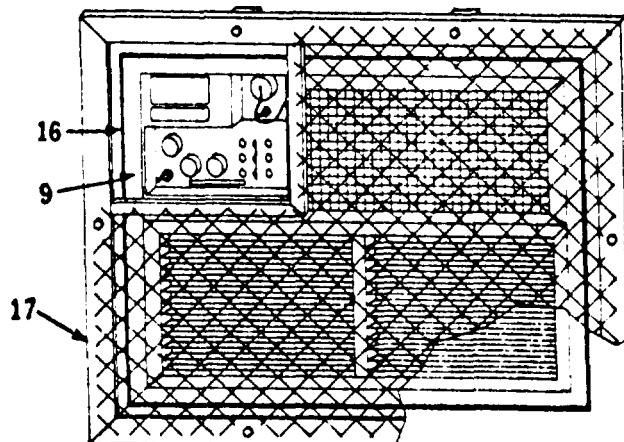

b. Connecting Power to ECU.

1. Set ECU MODE SELECTOR switch (1) to OFF position.
2. Remove cap (2) from receptacle (3).
3. Align end of ECU cable connector (4) and ECU power input receptacle (3). Push firmly until seated.
4. Screw connector lock ring (5) on receptacle (3).

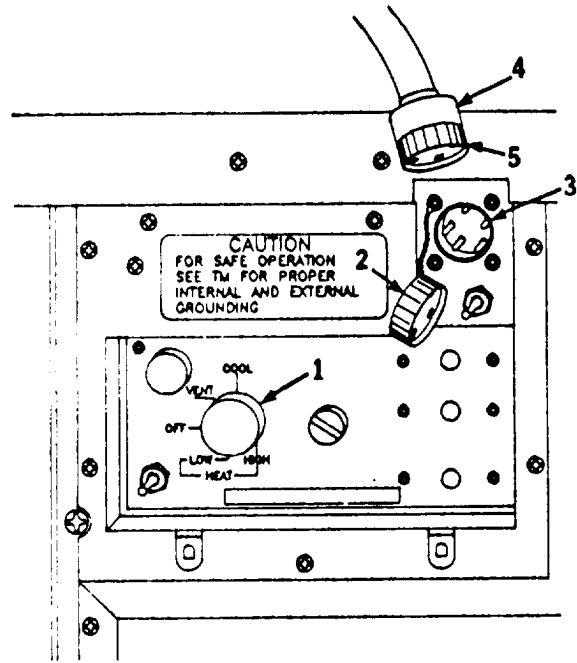

c. Repeat a and b above for remaining ECU.

d. Storing ECU Support Frames.

1. Remove four ring bolts (1) from both ECU support frames (2). Move frames to expanded side wall.

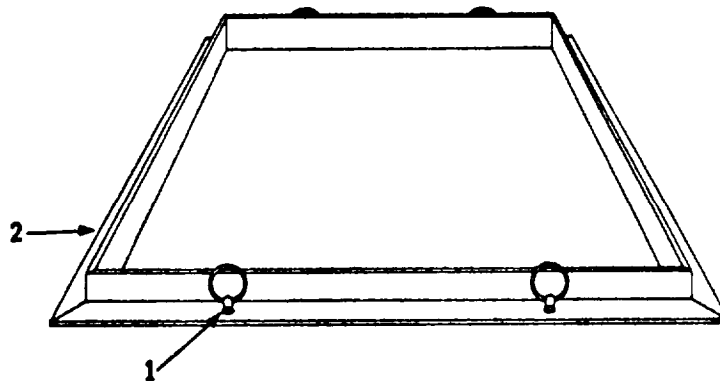

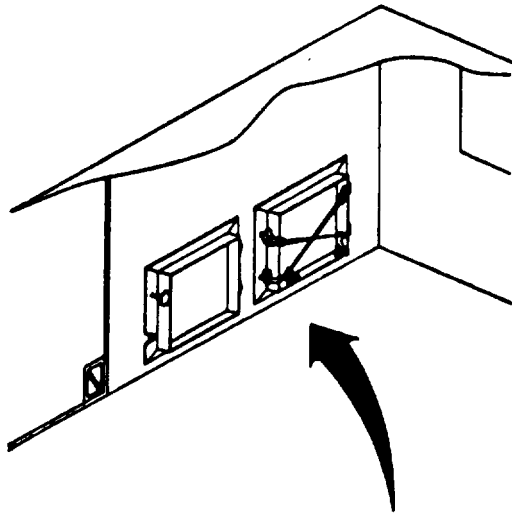

2. Position frames (2) against wall, align holes in frames with wall inserts and secure each frame with

3. Hook cargo straps (3) to ring bolts (1). Tighten and secure.

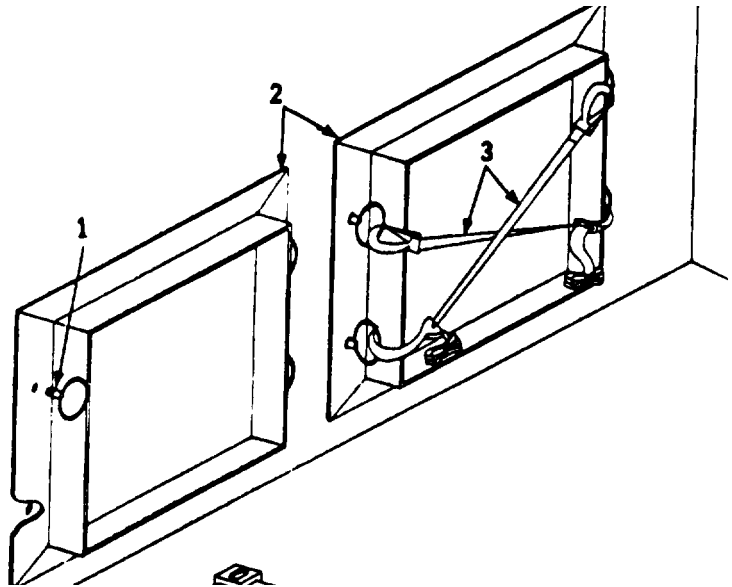

4. Obtain eight floor plugs (4) from shop storage chest. Install in floor inserts (5).

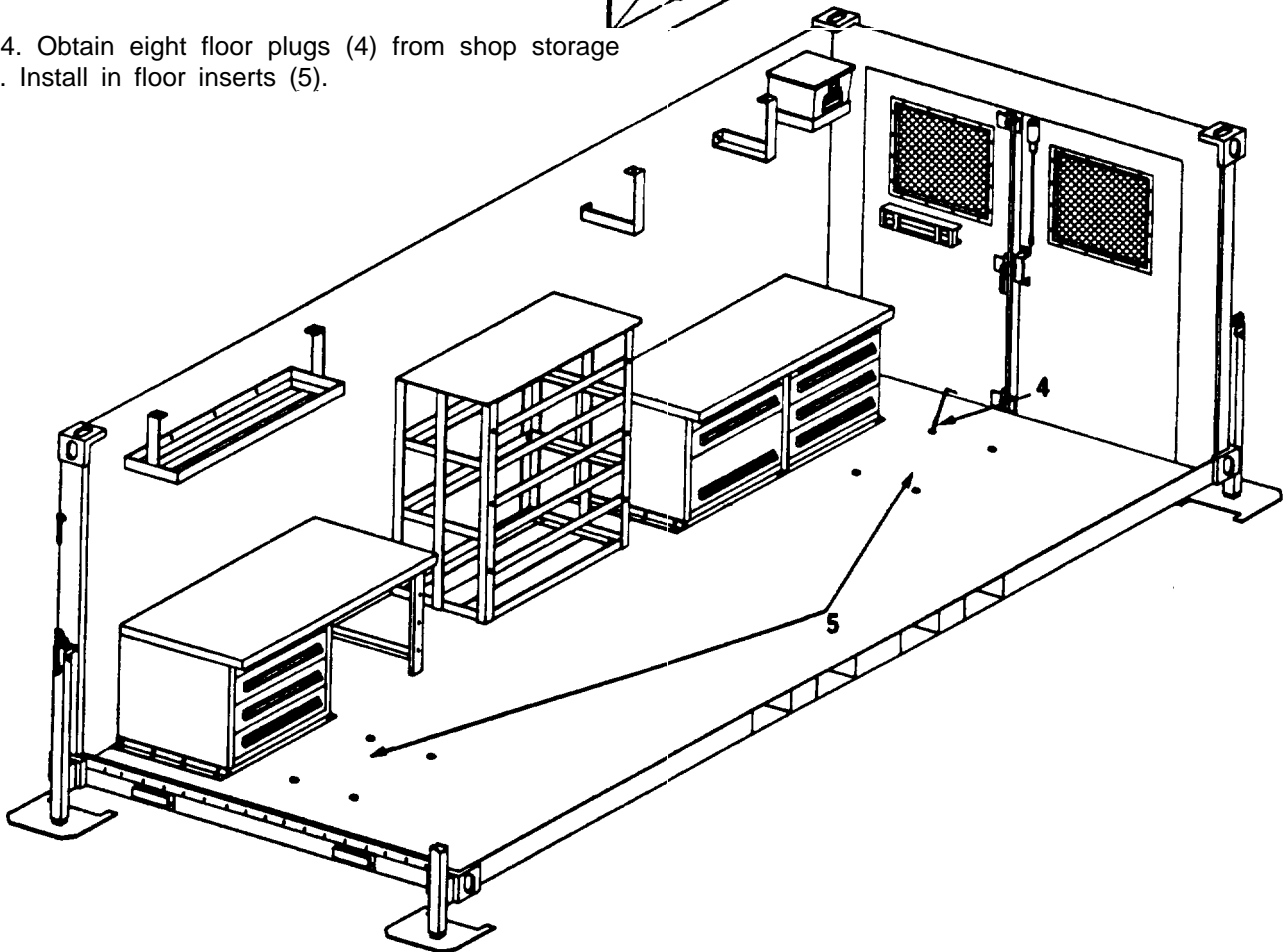

e. Positioning Cabinets for Operation.

1. Remove eight bolts (1), lockwashers (2) and washers (3) from brackets (4) located on two sides of cabinet (5). Store bolts, lockwashers, and washers in storage chest.

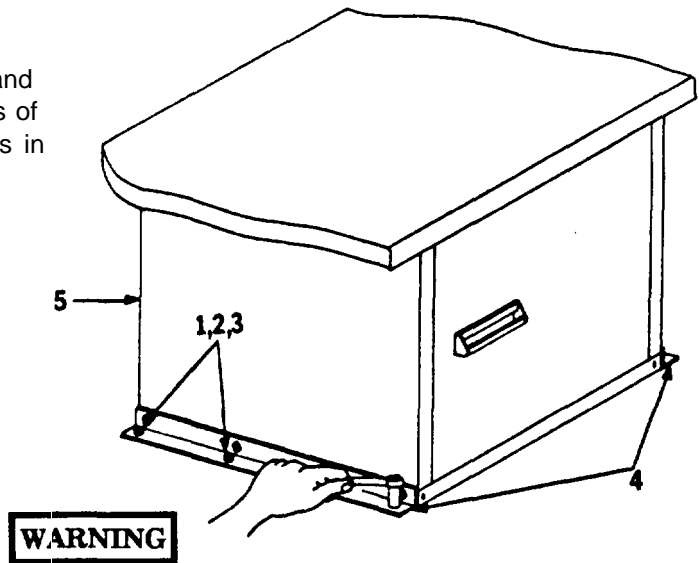

Cabinets are extremely heavy when fully equipped. At least two personnel are required to lift or move. Attempting to lift or move cabinet without sufficient personnel can result in severe injury.

2. Position cabinet (5) by sliding along floor to recommended location.

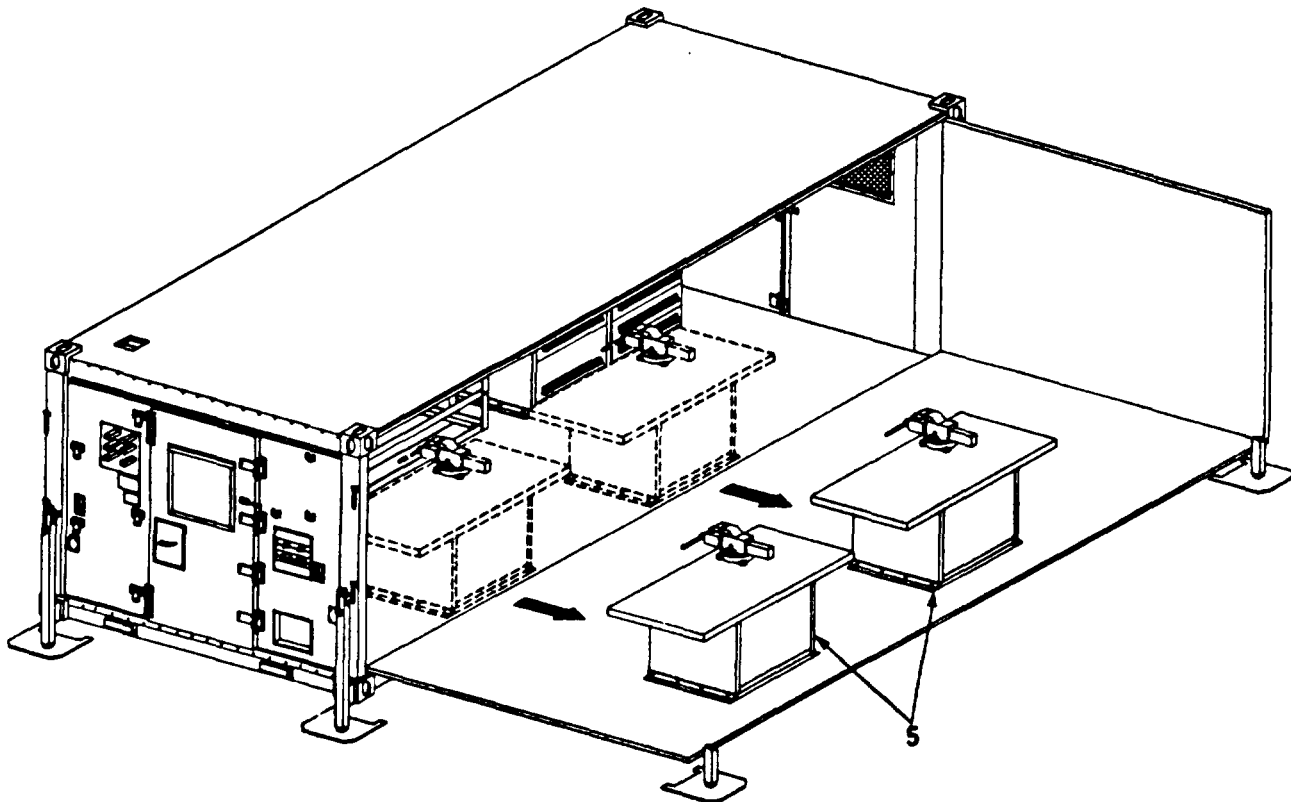

3. Repeat 1 and 2 above for remaining cabinet.

4. Obtain sixteen floor plugs (6) from shop storage chest and install into floor inserts (7).

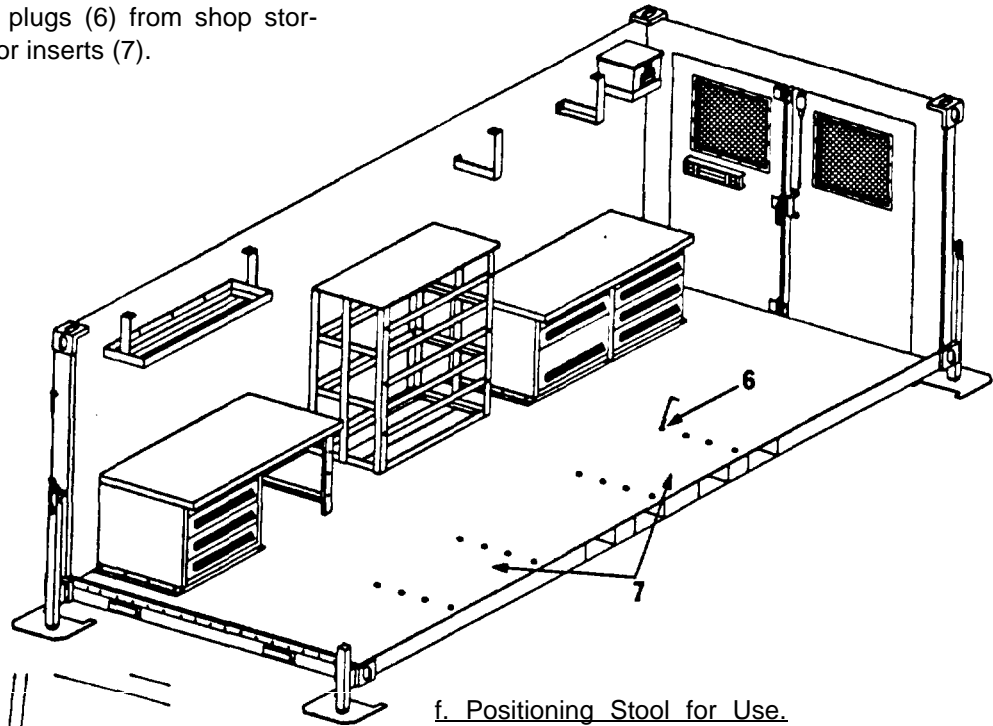

f. Positioning Stool for Use.

1. Remove one bolt (1), lockwasher (2) and washer (3) from inverted stool seat (4). Store bolt, lockwasher and washer in shop storage chest.

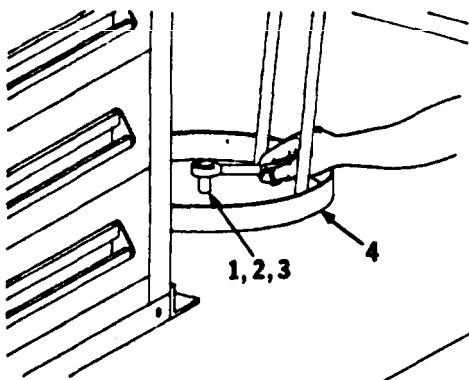

2. Position stool (4) at workbench.

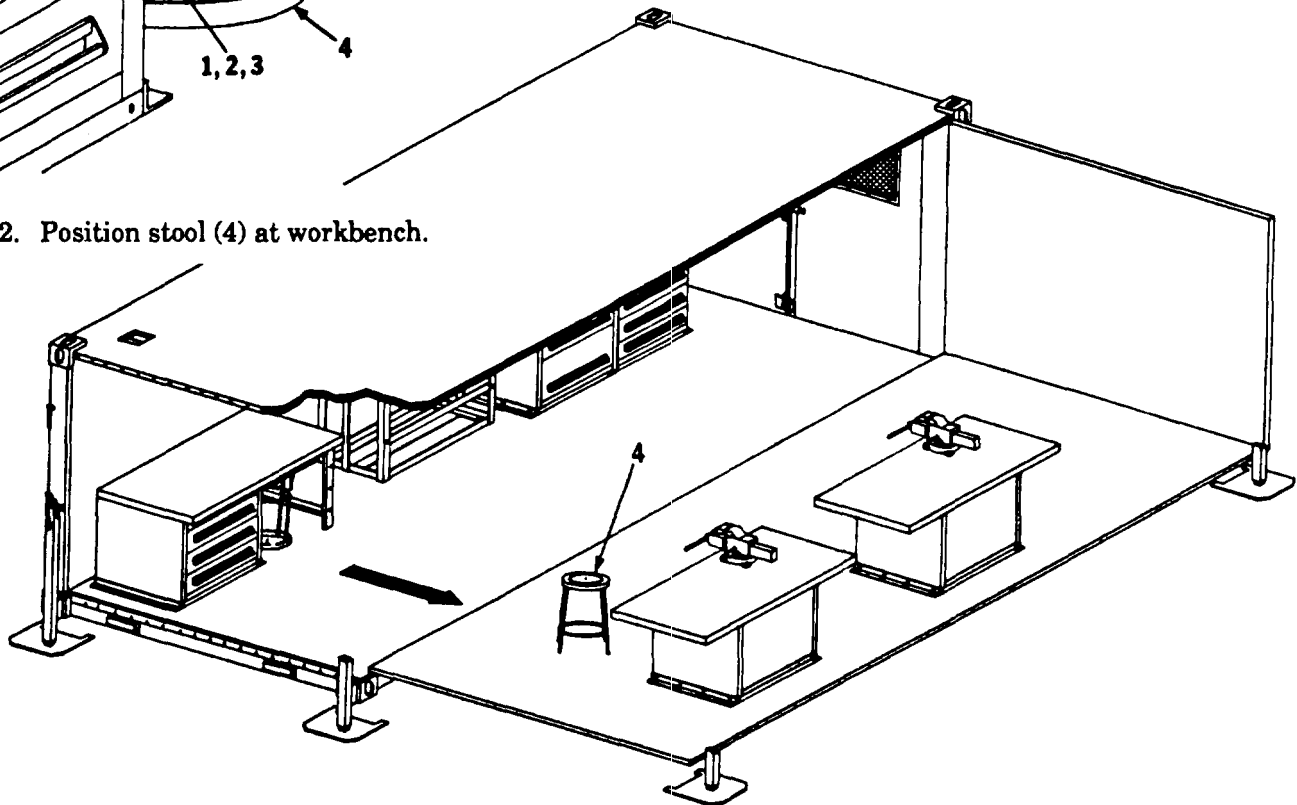

3. Obtain one floor plug (5) from shop storage chest and install into floor insert (6).

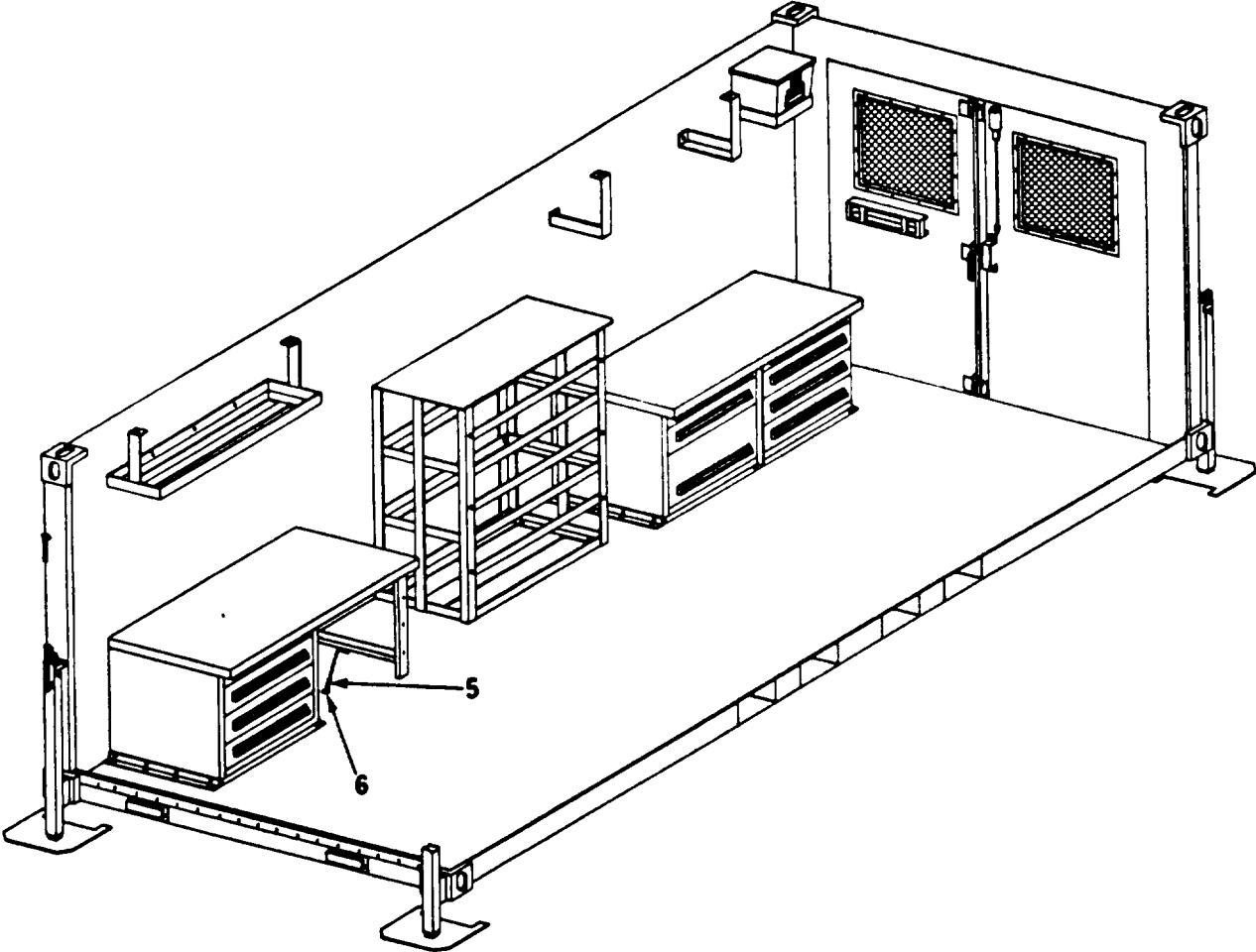

2-5. Other Shop Utilities. In addition to electrical power the shop is provided with connections for compressed air and water.

a. Connecting Compressed Air.

1. Remove protective dust cap (1) from air inlet nipple (2) at the service utility panel (3). Store in shop storage chest.

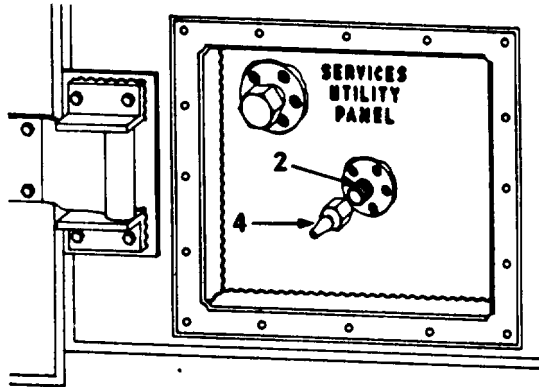
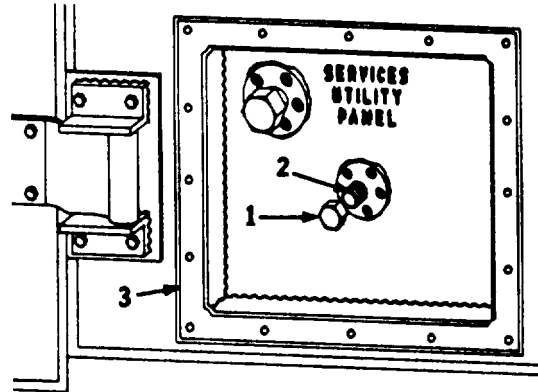

2. Obtain a quick disconnect coupling (4) from storage chest.

3. Install the quick disconnect coupling (4) on air inlet nipple (2).

4. Tighten coupling (4) securely.

b. Connecting Water Supply

1. Remove protective dust cap (1) from each end of water feed thru connector (2). Store in shop storage chest.

2. Install adapters and fittings as required.

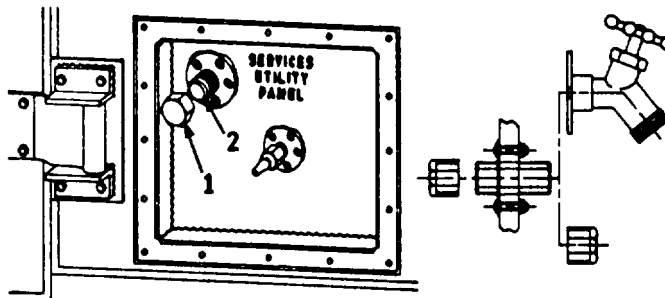

2-6. Storage of Hardware.

CAUTION

Care must be taken to ensure that proper hardware is used to secure equipment for transport. Lack of correct hardware could cause extensive damage to equipment or the shelter when shop is moved.

a. All hardware removed from equipment will be collected and placed in cotton mailing bags (see item 3, App E). Bags are stored in the shop storage chest until shelter is to be moved and equipment bolted to the floor.

b. Position storage chest (1) in mounting bracket (2).

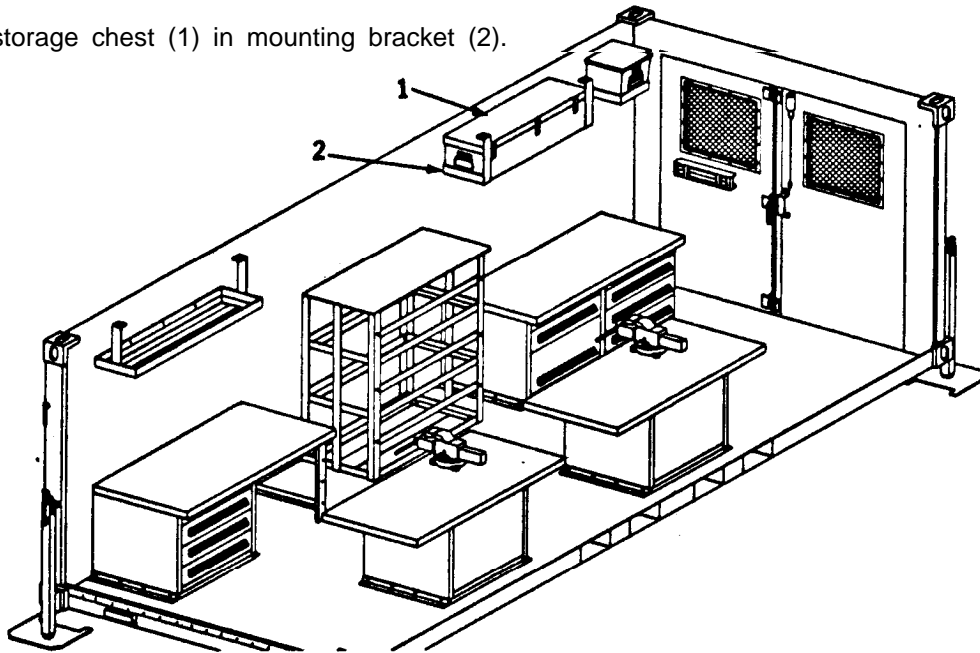

2-7. Checking Shelter Level. Once all equipment is in the recommended operational position recheck leveling of shelter. Use procedures in TM 10-5411-201-14 to verify and adjust level. Correct adjustment is essential to ensure proper operation of machine tools, doors and access panels. The Rotor Shop is now operational.

SECTION III. PREPARING SHOP FOR SHIPMENT OR STORAGE

2-8. Recover and Inspect Equipment Hardware.

a. Remove shop storage chest from mounting brackets.

CAUTION

Care must be taken to ensure that proper hardware is used to secure equipment for transport. Lack of correct hardware could cause extensive damage to equipment or the shelter when shop is moved.

b. Recover cotton mailing bags with hardware from shop storage chest.

c. Inspect hardware for damage or missing parts.

2-9. Disconnecting Shop Utilities (Other Than Electrical).

a. Disconnecting Water Supply.

1. Obtain two protective dust caps (1) from shop storage chest.
2. Remove adapters and fittings from connector (2) at service panel.
3. Install dust cap on each end of feed thru connector (2), tighten securely.

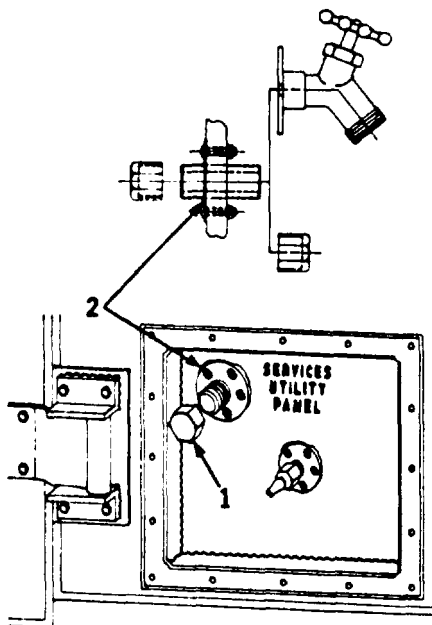

b. Disconnecting Compressed Air.

1. Remove male quick-disconnect coupling (1) from the air inlet nipple (2) at service utility panel. Store in shop storage chest.
2. Obtain a dust cap (3) from storage chest.

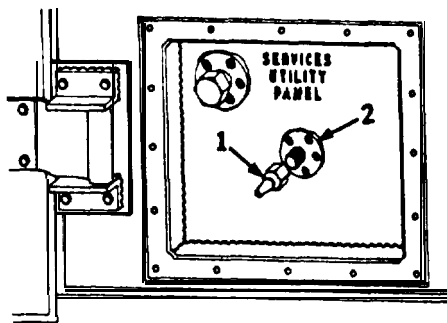

3. Install dust cap (3) on air inlet nipple (2), tighten securely.

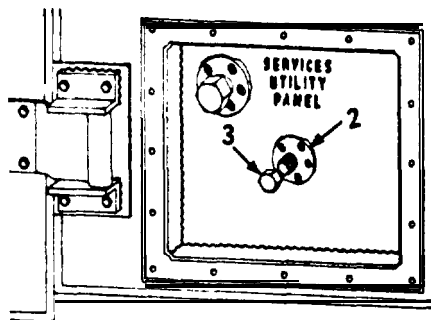

2-10. Positioning Shop Equipment for Transport. The following procedures, and recommended sequence, for moving equipment from the operational mode to the transport or storage mode will be observed.

a. Positioning Stool for Transport.

1. Remove floor plug (1) from insert at transport location of stool. Store plug in storage chest.

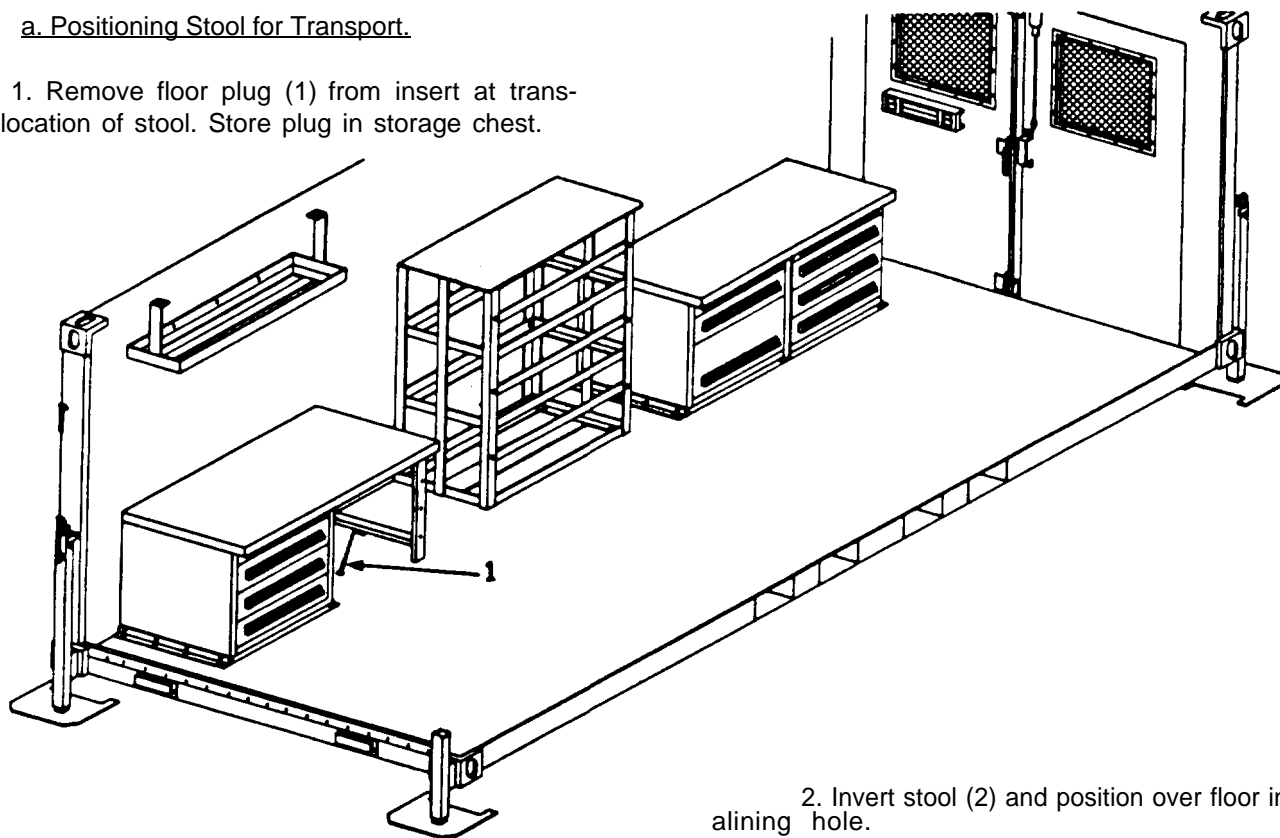

2. Invert stool (2) and position over floor insert, alining hole.

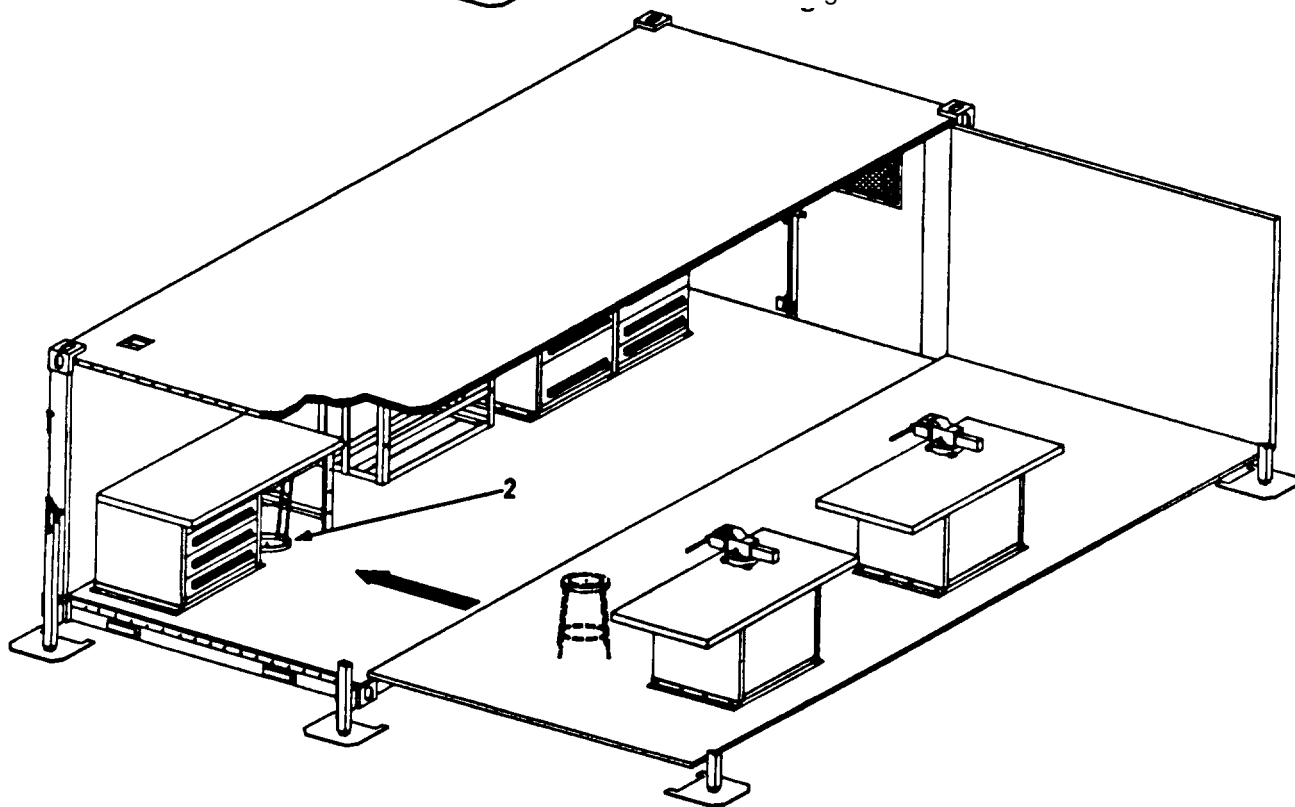

CAUTION

Torque values must be observed to prevent possible damage to equipment or the shelter. Improper procedures could result in extensive damage to government property. See App. G.

3. Install one bolt (3), lockwasher (4) and washer (5) and torque.

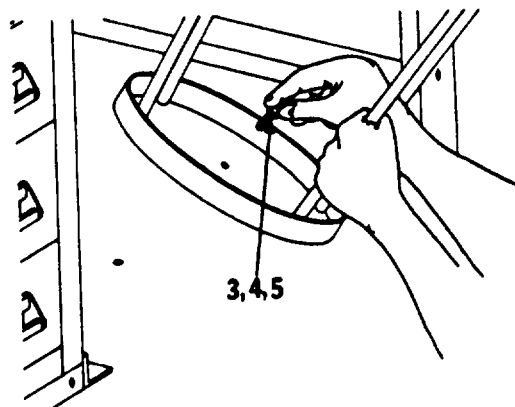

b. Positioning Cabinets for Transport.

1. Remove sixteen floor plugs (1) from inserts at transport location of cabinets (2). Store plugs in storage chest.

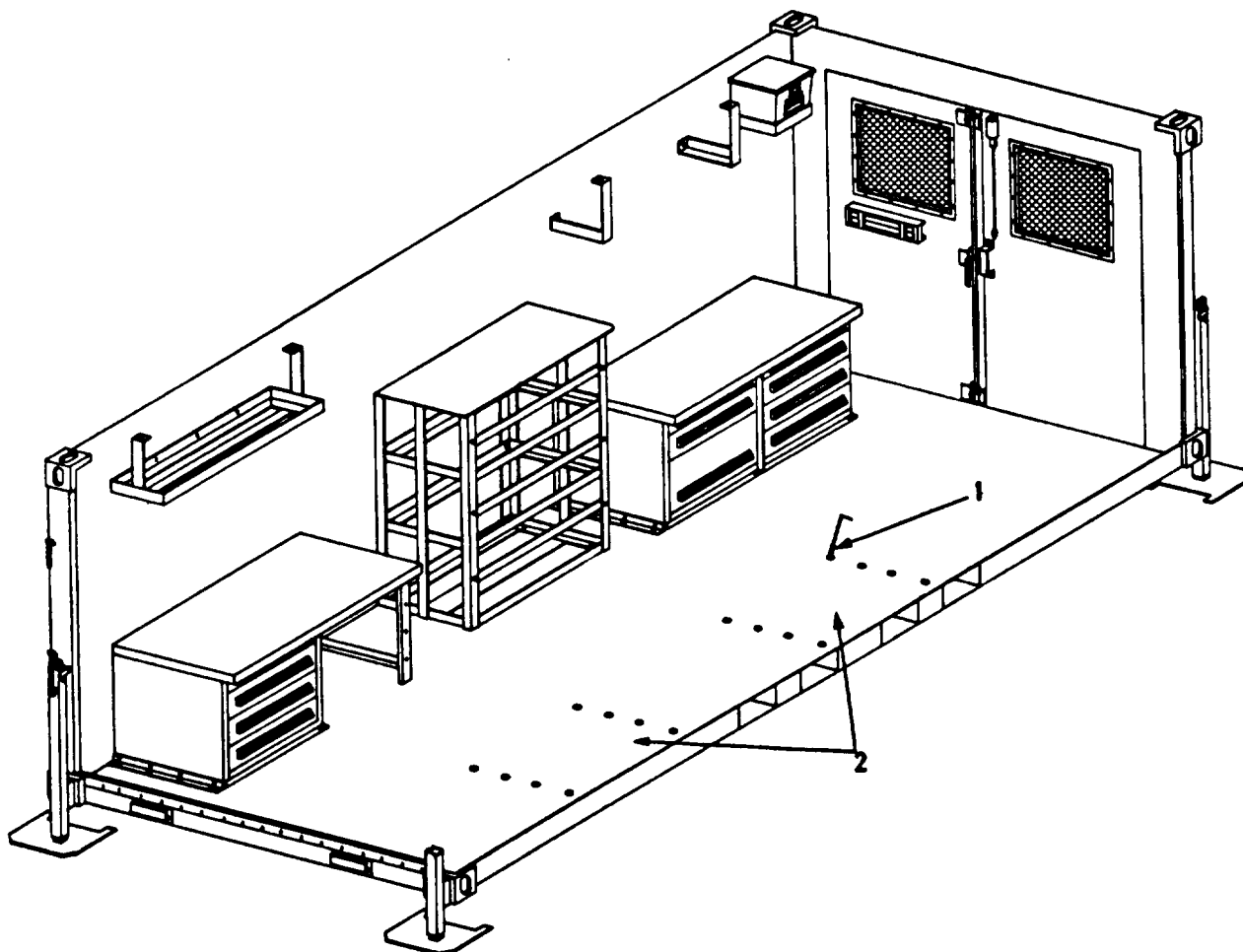

WARNING

Cabinets are extremely heavy when fully equipped. At least two personnel are required to lift or move. Attempting to lift or move cabinet without sufficient personnel can result in severe injury.

2. Position cabinet (3) by sliding along floor to transport location.

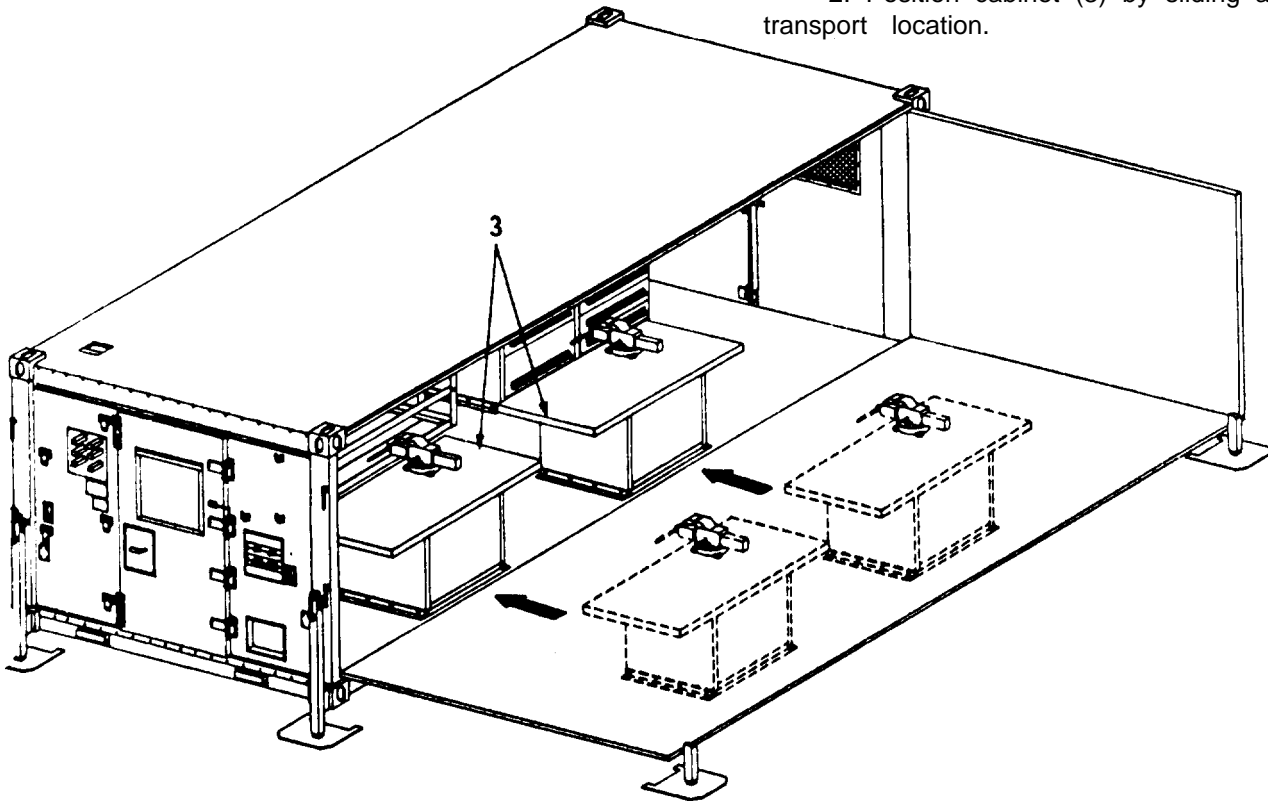

CAUTION

Torque values must be observed to prevent possible damage to equipment or the shelter. Improper procedures could result in extensive damage to government property. See App. G.

3. Aline holes in support brackets (4) with floor inserts, Install eight bolts (5), lockwashers (6) and washers (7) and torque.

4. Repeat 2 and 3 above for remaining cabinet.

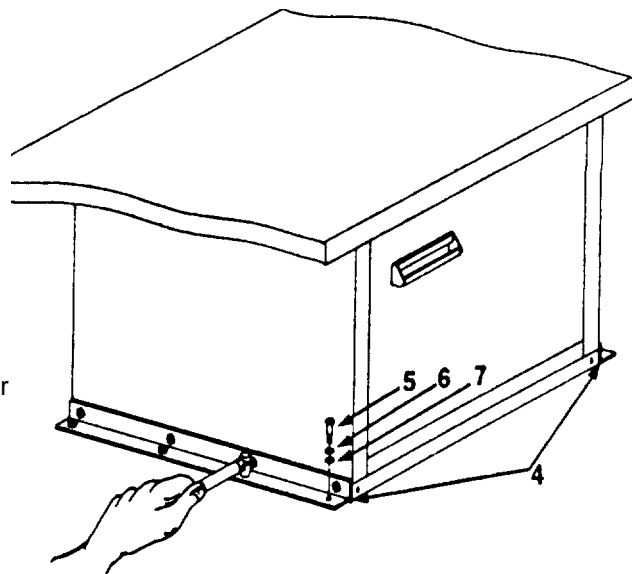

c. Installing ECU Support Frames.

1. Remove eight floor plugs (1) from inserts at transport location of ECUs (2). Store plugs in storage chest.

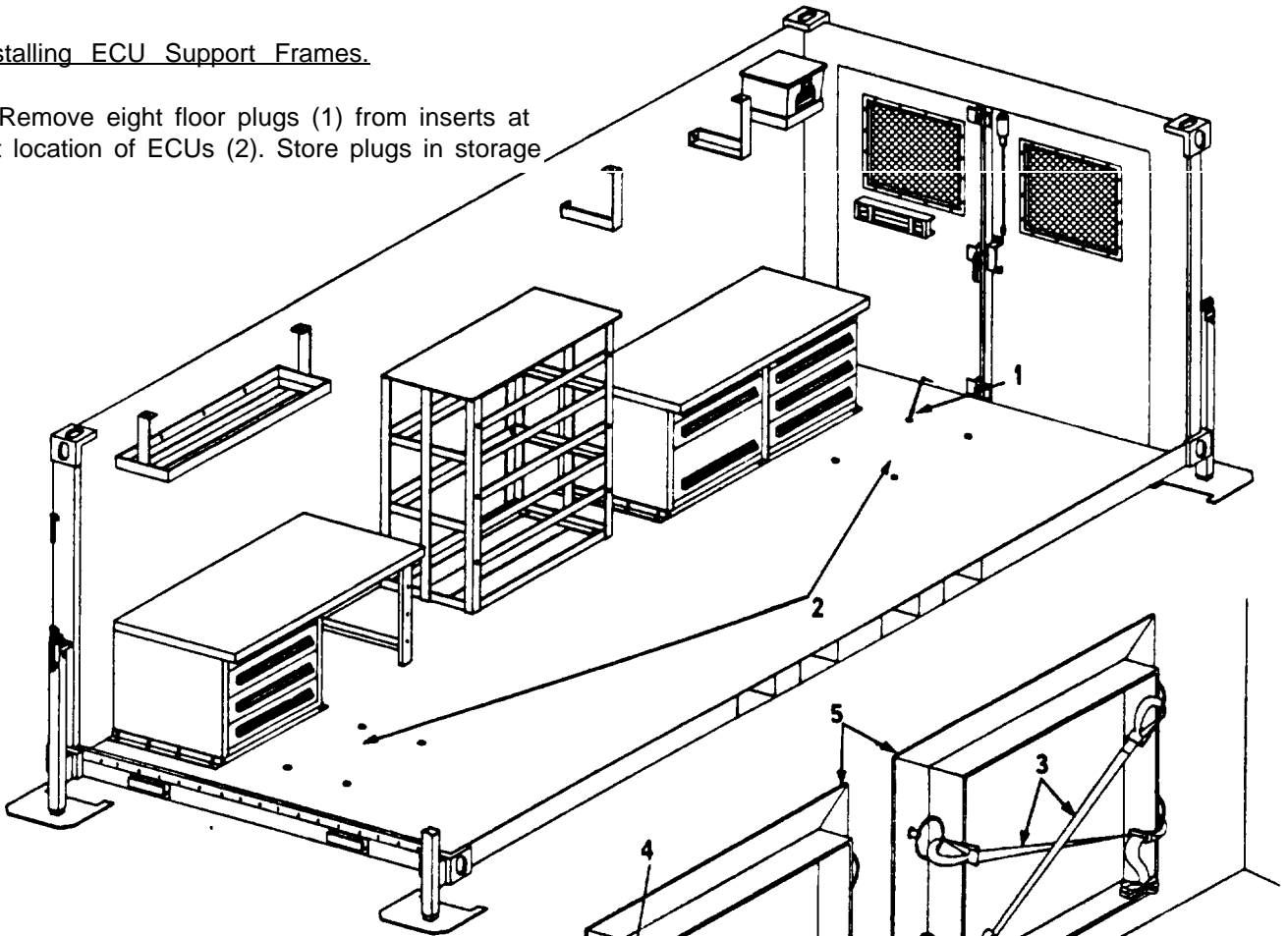

2. Loosen and remove cargo straps (3).

3. Remove four ring bolts (4) securing each frame (5) to wall. Remove frames.

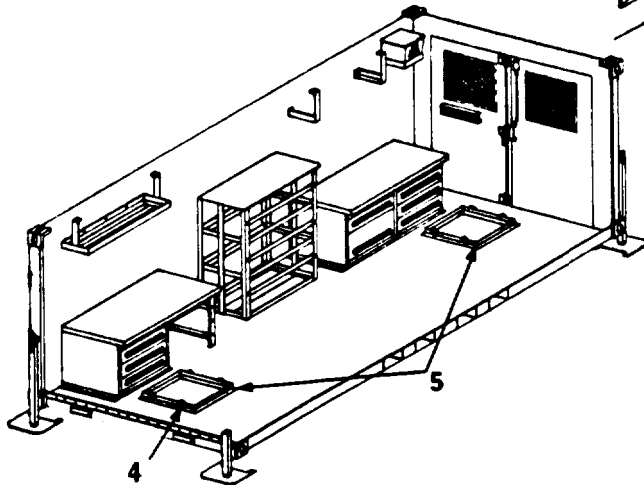
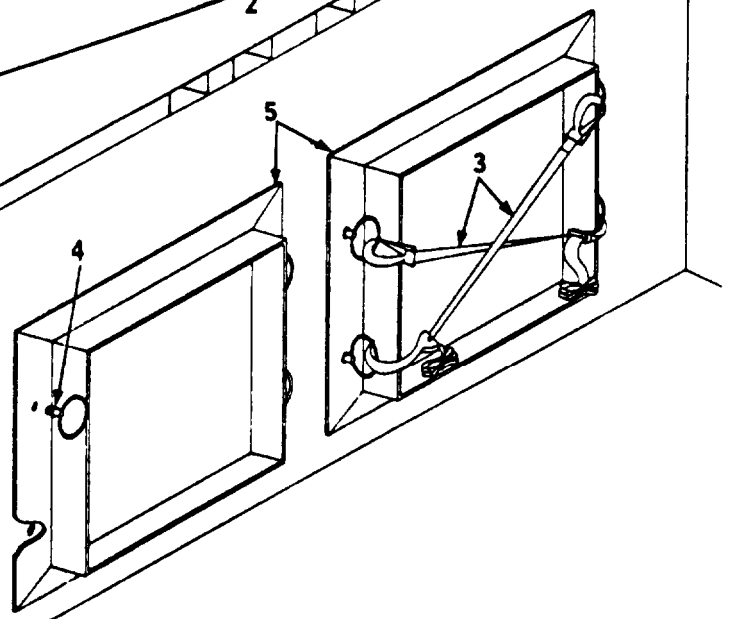

4. Position ECU frames (5) over floor inserts and align holes.

5. Install four ring bolts (4) in each and securely tighten.

d. Disconnecting Power from ECU.

1. Set ECU MODE SELECTOR switch (1) in OFF position.
2. Unscrew lock ring (2) and pull connector (3) from ECU receptacle (4). Secure cable (5) with hook and loop fasteners.
3. Replace cap (6) on receptacle (4).

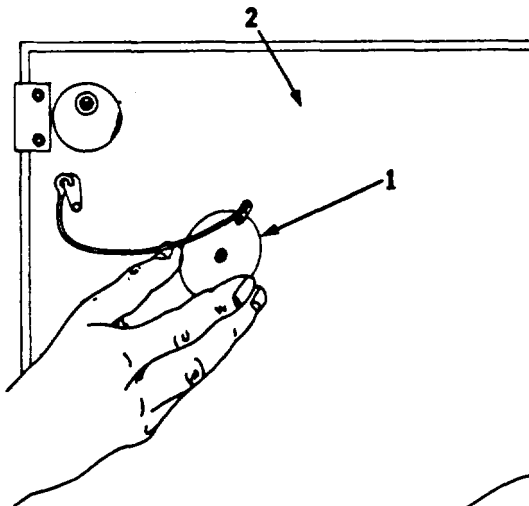
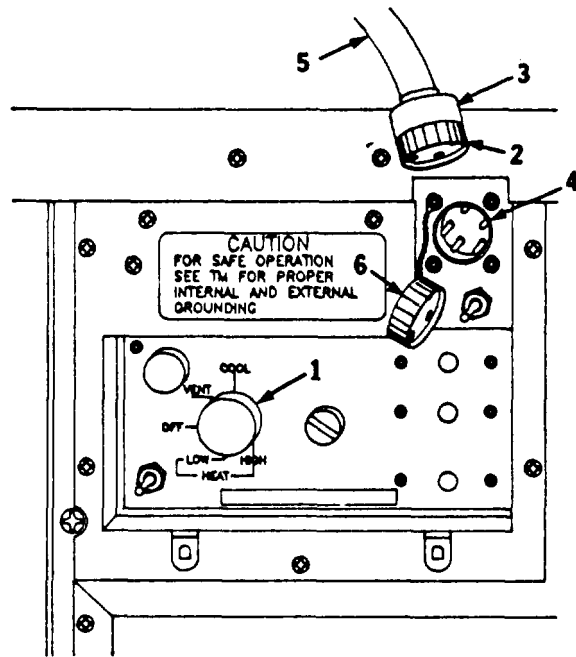

e. Positioning ECUs for Transport.

1. Remove four plugs (1) on bottom of ECU shelf (2).
2. Remove mounting hardware securing ECU (3) to fold-down shelf (2) IAW TM 5-4120-384-14. Store hardware in shop storage chest.

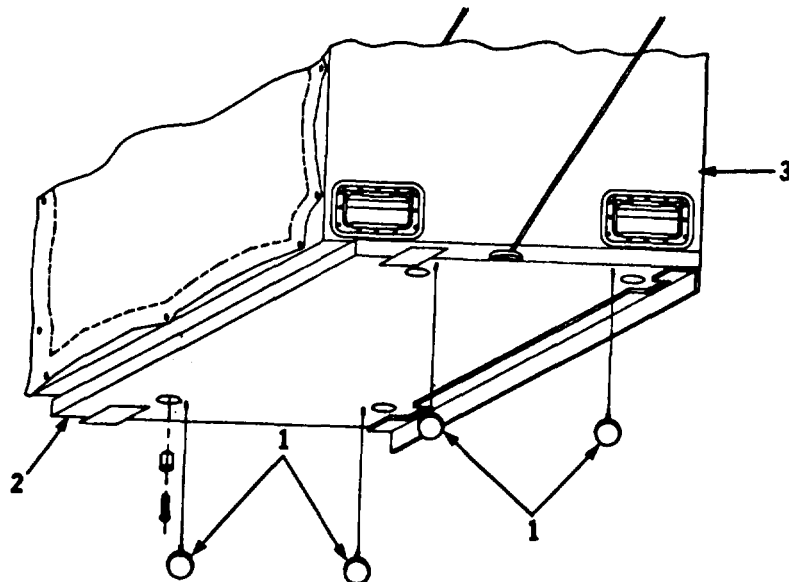

WARNING

Four people are needed when moving or lifting the Environmental Control Units (ECUs). Each unit weighs approximately 290 pounds. Trying to move or lift an ECU without sufficient help can cause serious injury to personnel.

3. Grasp lift handles (4) and slide ECU (3) off fold-down shelf (2).

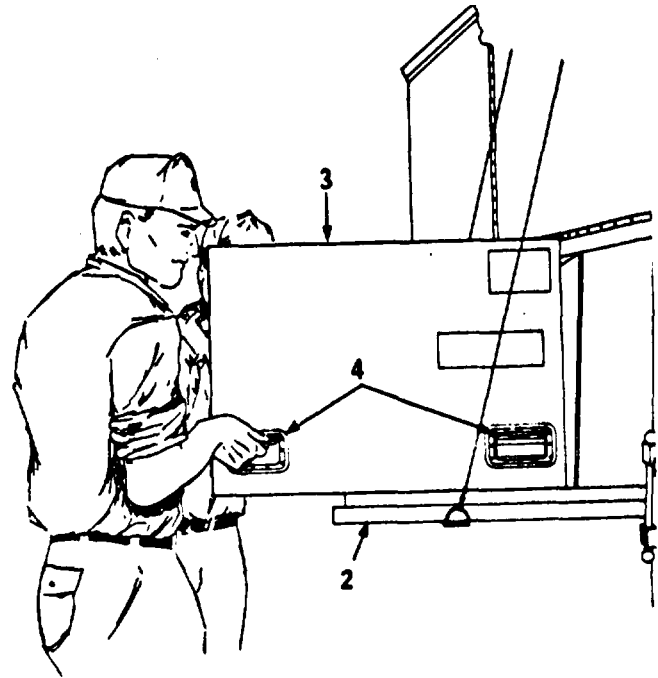
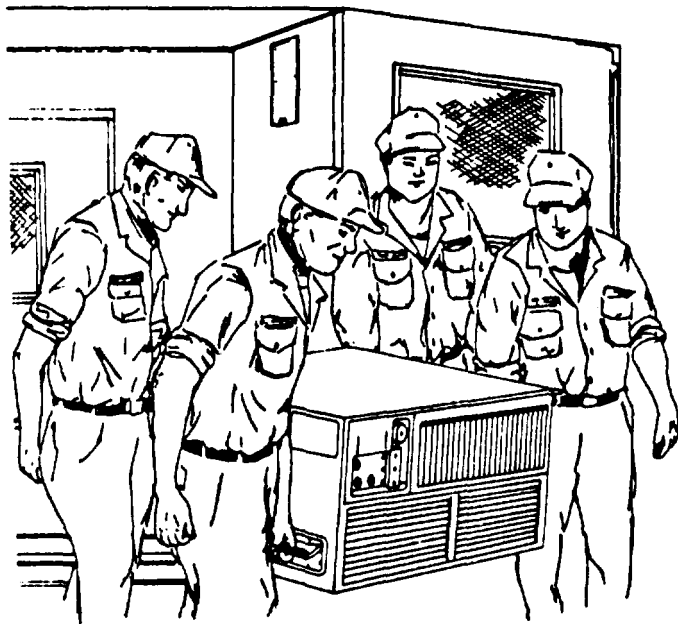

4. Carry ECU (3) inside and position in floor frame (5).

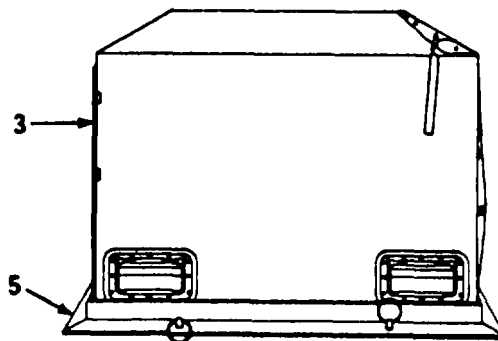

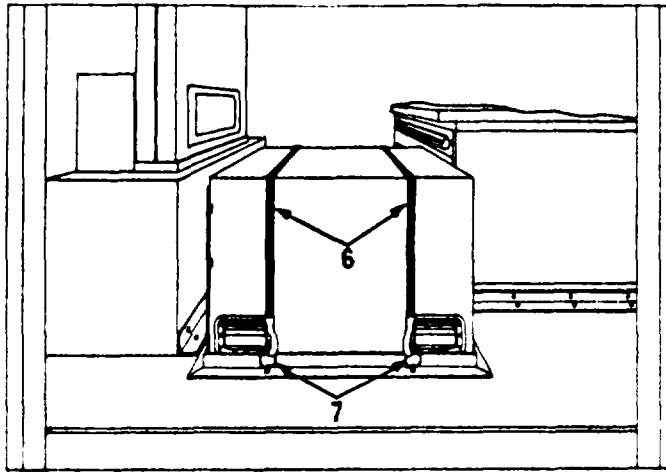

5. Place two cargo straps (6) on ECU and hook to ring bolts (7). Tighten cargo straps to secure ECU in place.

6. From outside shelter, remove ECU seal (8) from bottom of frame (9). Close ECU shelf (2) and store ECU seal in shop storage chest.

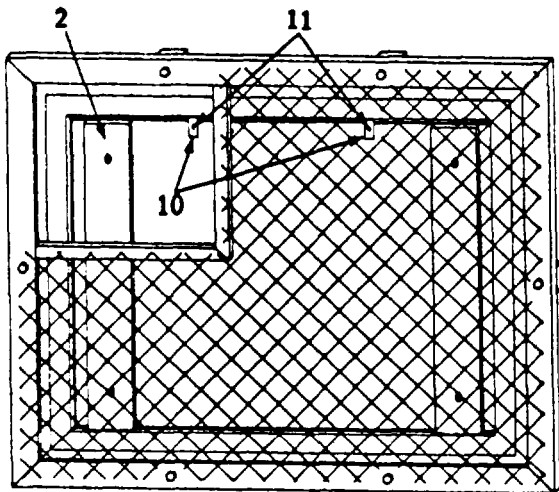
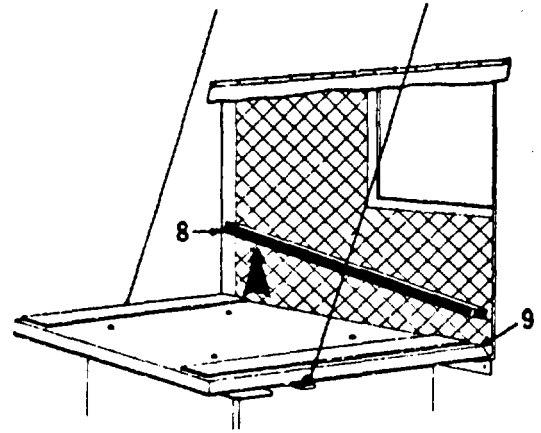

7. From inside shelter, turn latches (10) to locked position and tighten latch bolts (11).

8. Insert four plugs (1) in ECU shelf (2).

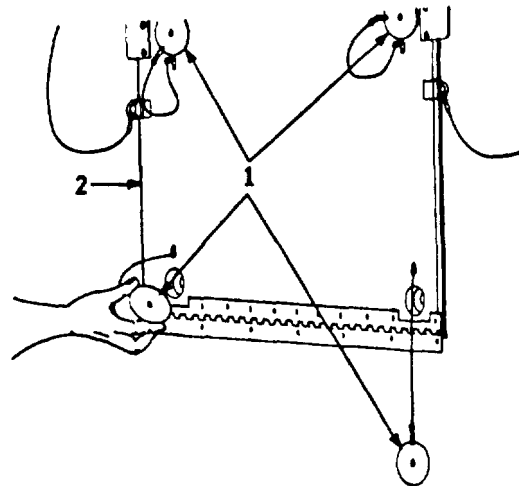

f. Repeat d and e above for remaining ECU.

2-11. Power Shutdown.

WARNING

HIGH VOLTAGE exists in the electrical system of the shop. All electrical inspections, repairs or replacement will be performed with the power off and only by qualified electricians. Serious shock hazards exist which could result in injury or death to personnel.

a. Power Off at Shelter.

1. Ensure all electrical tools and shop equipment are turned off.
2. Set main (1) and individual (2) circuit breakers in circuit breaker panel (3) to OFF position.

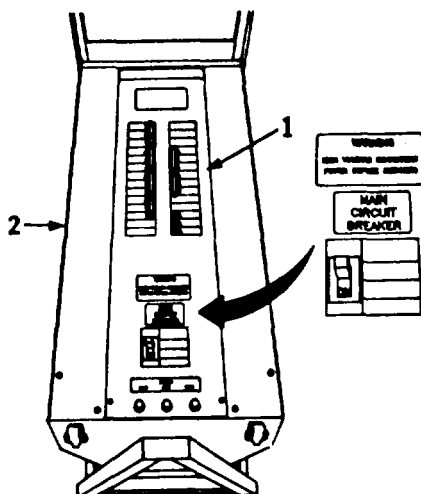
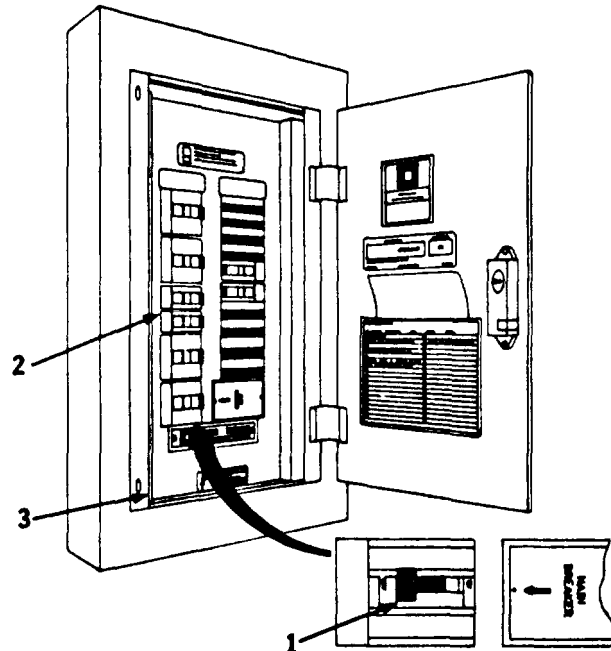

- b. Power Off at Power Distribution Panel. Set corresponding shelter power cable circuit breaker (1) in power distribution panel (2) to OFF position.

c. Disconnecting Shelter Power Cable.

1. Disconnect male end of shelter power cable (1) from power distribution panel (2).

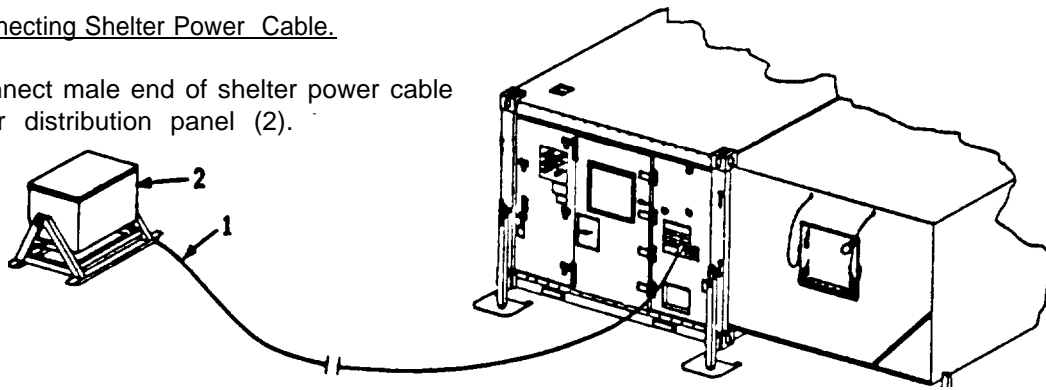

2. Unscrew lock ring (3) on J1 receptacle (4) on shelter power entry panel (6) and remove cable connector (5) from receptacle.

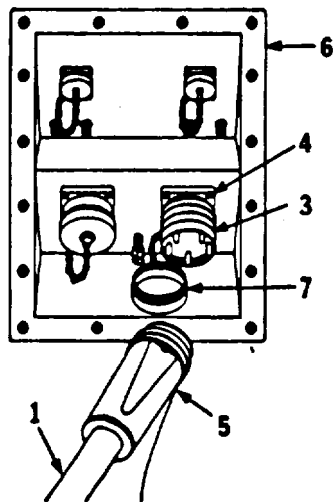

3. Replace dust cap (7).

4. Clean cable (1) and store in shelter.

d. Disconnecting Power Distribution Panel from Power Source.

1. Ensure all circuit breakers (1) in the power distribution panel (2) are in the OFF position.

2. Ensure all shelter power cables (3) are disconnected from the power distribution panel (2).

3. A qualified electrician should disconnect power distribution panel power cable (4) from the power distribution panel (2) and the power source IAW TM 5-6150-226-13&P.

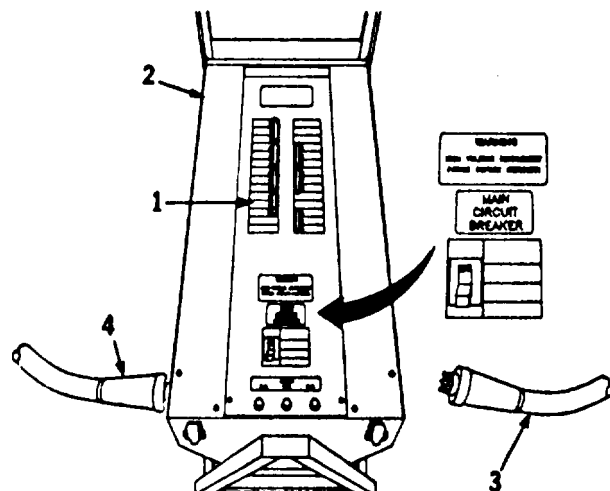

e. Removing External Ground Rod.

1. Remove external ground rod IAW TM 10-5411-201-14 and TC 11-6.
2. Store ground rod assembly in shop.

2-12. Administrative Storage Procedures. In the event the Rotor Shop is to be placed in administrative storage, the provisions of AR 750-1, TM 55-1500-204-25/1, and applicable shop equipment TMs will be followed.

2-13. Closing the Shelter.

WARNING

When all equipment is stored on the stationary side of the shelter, the limited floor space presents an obstacle to operating personnel. This is most critical during the raising and lowering of the roof panel. Failure to observe closing instructions could result in serious injury to personnel. Personnel inside the shelter could become trapped between the roof panel and equipment.

a. Installing Counterbalance Cables.

1. Remove screws (1) at both corners of fold-out floor.

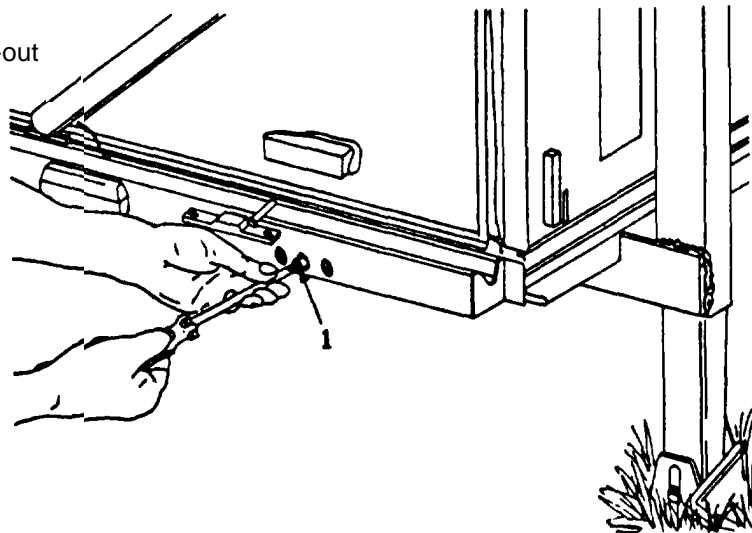
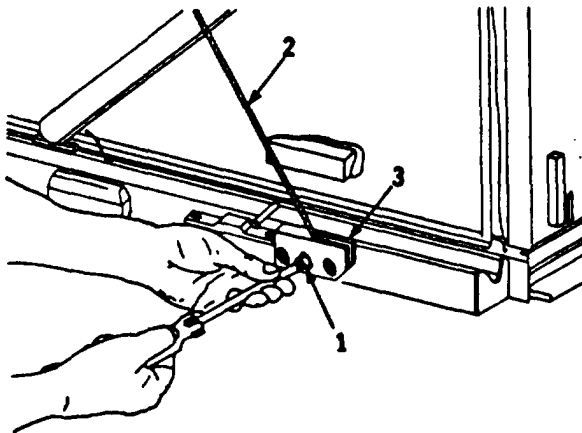

2. Install cable (2) and retainer block (3) with screws (1).

3. Proceed with closing the shelter as outlined in TM 10-5411-201-14.

b. After the shelter has been closed and prepared in accordance with TM 10-5411-201-14, the Rotor Shop is ready for transport or storage.

CHAPTER 3 MAINTENANCE INSTRUCTIONS

SECTION I. REPAIR PARTS, SPECIAL TOOLS, TMDE, AND SUPPORT EQUIPMENT

3-1. Common Tools and Equipment. For authorized common tools and equipment refer to the Table/Modified Table of Organization and Equipment (TOE/MTOE) applicable to the AVIM unit and to the Supply Catalog (SC) applicable to the Rotor Shop.

3-2. Torque Values. All equipment or tools secured to the floor or wall of the shelter must be carefully tightened to specific torque limits. These torque limits are contained in Appendix G of this manual.

3-3. Special Tools, TMDE, and Support Equipment. No special tools are required.

3-4 Repair Parts. Repair parts are listed and illustrated in Appendix D of this manual.

3-5. Repair Procedures. Inspection, repair and replacement tasks for all fabricated brackets and components encompass similar procedures due to the commonality of the materials and hardware utilized. The inspection, repair and replacement tasks for the book rack are presented as a guide for maintenance procedures for the remainder of the fabricated components as listed in Appendix F.

SECTION II. SERVICE UPON RECEIPT

3-6. Checking Unpacked Equipment.

a. Inspect the equipment for damage incurred during shipment. If the equipment has been damaged, report the damage on DD Form 6, Packaging Improvement Report.

b. Check the equipment against the packing slip to see if the shipment is complete. Report all discrepancies in accordance with the instructions of DA PAM 738-751.

c. Check to see whether the equipment has been modified.

d. After equipment has been positioned to the recommended operational floor plan, check all items requiring service. Preventive maintenance (PM) and preoperational services will be performed IAW applicable equipment TMs.

SECTION III. MAINTENANCE PROCEDURES

3-7. Fasteners-Inspect

3-7

This task covers: Inspection of common fasteners.

INITIAL SETUP

Tools:

Basic Issue Items (BII) - App C

Wrench, Torque 0-600 incpounds, NSN 5120-00-288-8865

Personnel Required:

68D Aircraft Overtrain Repairer

INSPECTION

1. Inspect bolts.

- a. Inspect bolts for damaged threads, rounded head, or other damage prior to installation and upon removal.

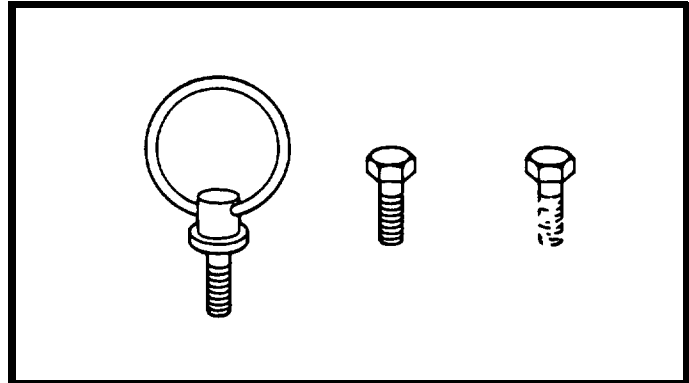

- b. Replace bolts as necessary.

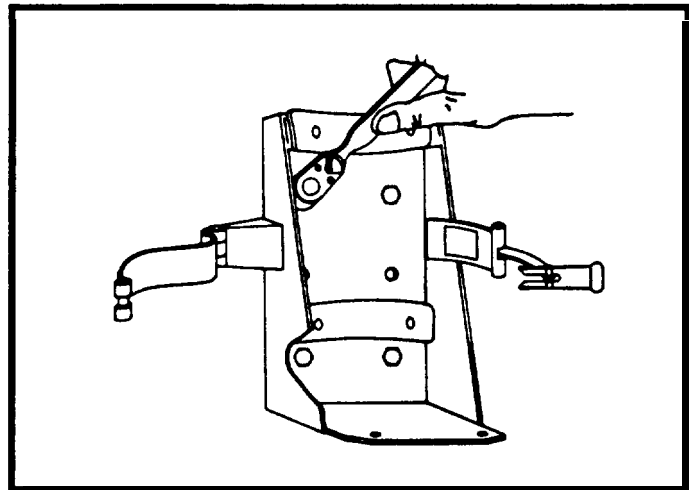

GO TO NEXT PAGE

3-7. Fasteners - Inspect (Cont)

3-7

- c. Upon installation, if bolt does not tighten to spec torque (App G), remove and reinspect bolt. Proceed to Step 2, if bolts are serviceable.

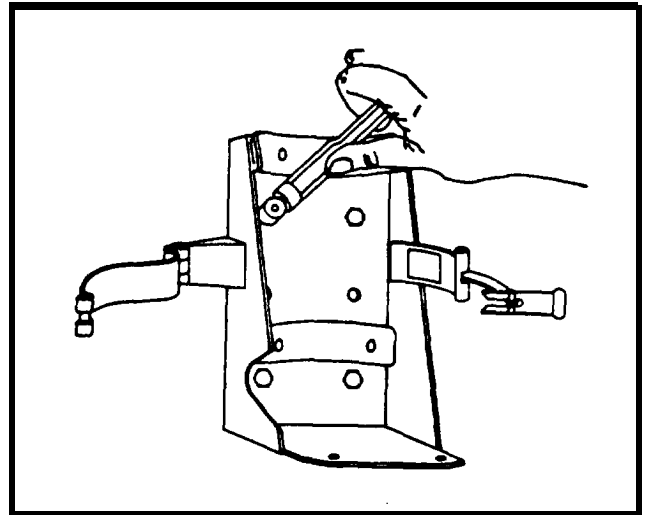
**2. Inspect Inserts.**

- a. Clean insert of foreign debris.
- b. Inspect inserts for broken threads and determine if insert has broken loose.
- c. Replace IAW TASK 3-8, if conditions in Step 2 exist.

END OF TASK

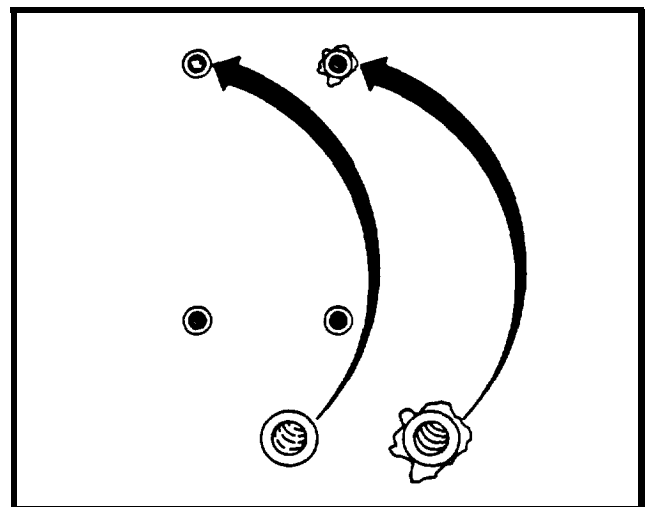

3-8. Inserts - Replace

3-8

This task covers: Replacement of inserts

INITIAL SETUP

Personnel Required:

68D Aircraft Powertrain Repairer

Reference Information:

TM 10-5411-201-14

WARNING

Methylethylketone (MEK), used to clean replacement inserts, is flammable and toxic. Use only in well ventilated areas. Breathing vapors can cause headaches and nausea. Repeated contact with skin can cause irritation. If irritation persists see a doctor. If in contact with eyes, wash immediately with water for 15 minutes and seek medical attention.

Safety goggles will be worn when drilling and cleaning holes for insert replacement. Flying chips can cause eye injury or blindness.

REPLACEMENT

Perform task IAW TM 10-5411-201-14.

END OF TASK

3-9. Fixtures - Fire Extinguisher - Removal/Installation

3-9

This task covers: Removal and installation of the fire extinguisher

INITIAL SETUP

68D Aircraft Powertrain Repairer

REMOVAL

Release clamp (1) securing fire extinguisher (2) in bracket (3) and remove fire extinguisher.

INSTALLATION

Place fire extinguisher (2) in bracket (3) and lock clamp (1) to secure fire extinguisher.

END OF TASK

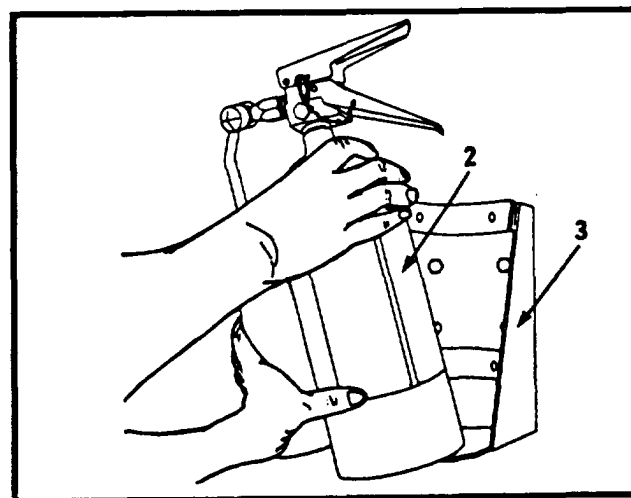
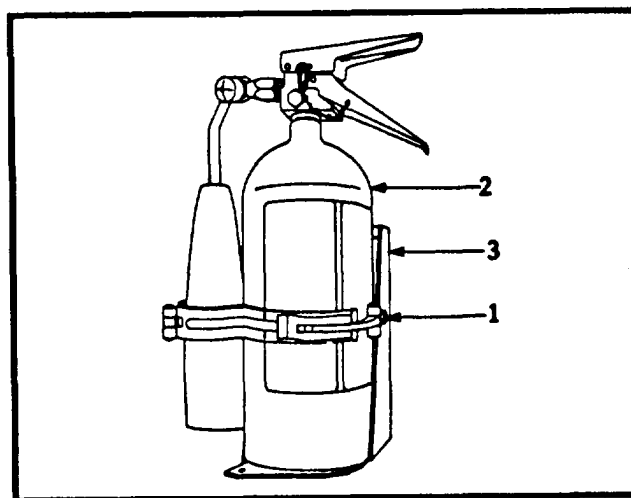

3-10. Fixtures - Fire Extinguisher Mounting - Inspect

3-10

This task covers: Inspection of fire extinguisher mounting

INITIAL SETUP

Personnel Required:

68D Aircraft Powertrain Repairer

Equipment Condition:

Fire Extinguisher Removed

TASK 3-9

INSPECTION

NOTE

Four additional wall inserts, inside cargo door on end wall, have been provided as alternate fire extinguisher mounting point.

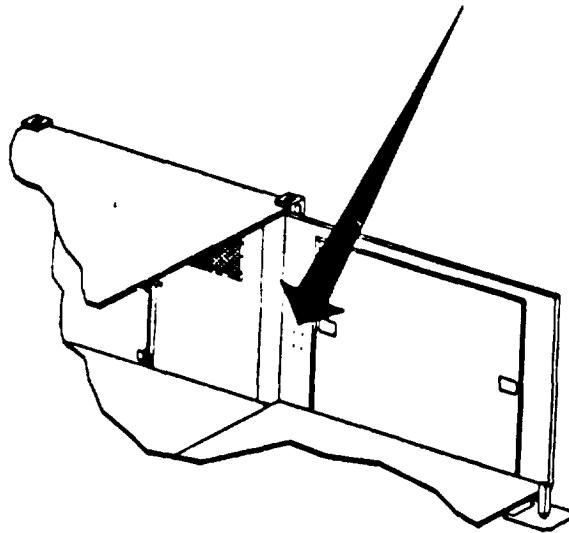

GO TO NEXT PAGE

3-10. Fixtures - Fire Extinguisher Mounting - Inspect (Cont)

3-10

1. Check fire extinguisher bracket (1) for security.

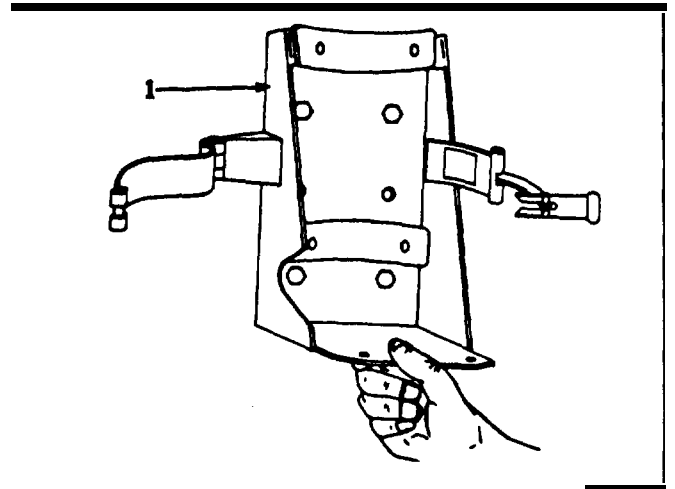

2. Check torque (App G) on bolts (2) when bracket (1) is loose.

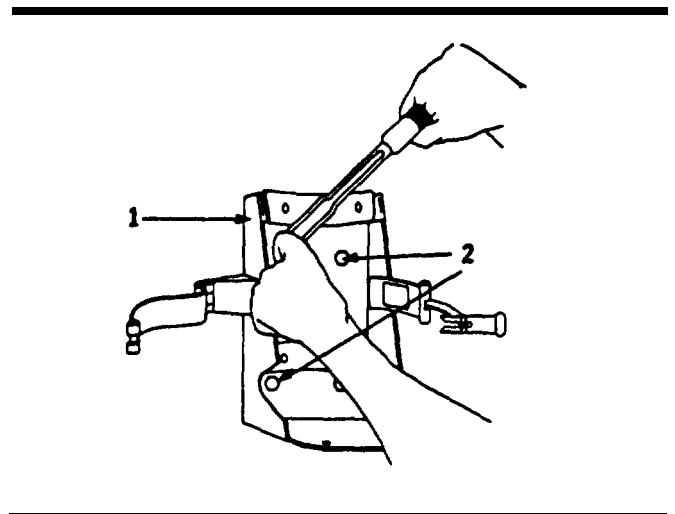

3. Remove bolts (2), lockwashers (3) and washers (4) when unable to tighten bolts (2) to specified torque (App G). Inspect bolts (2) and inserts IAW TASK 3-7.

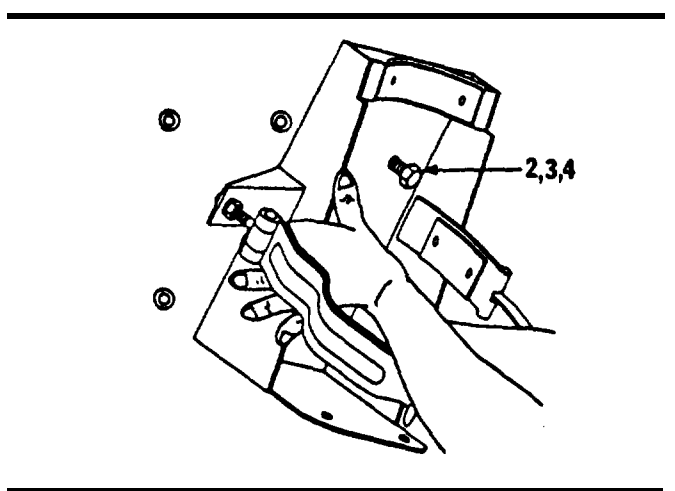

GO TO NEXT PAGE

3-10. Fixtures - Fire Extinguisher Mounting - Inspect (Cont)

3-10

4. Position fire extinguisher bracket (1) alining holes with wall inserts. Install bolts (2), lockwashers (3), and washers (4) and torque (APP G).

END OF TASK

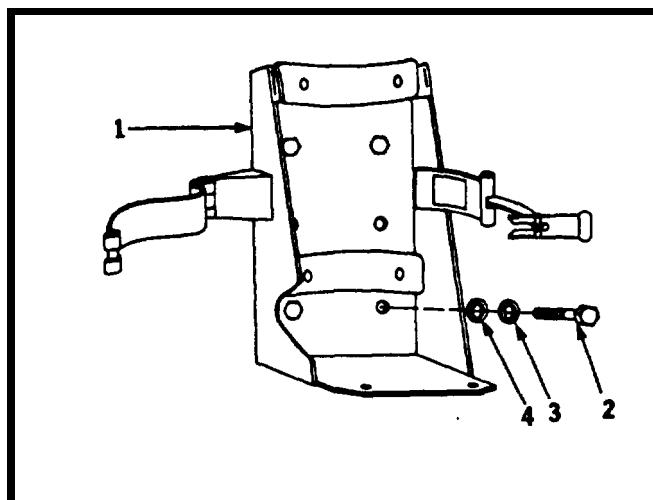

3-11. Water/Oil Separator Mounting - Inspect

3-11

This task covers: Inspection of water/oil separator mounting

INITIAL SETUP**Tools:**

Basic Issue Items (BII) - App C

Wrench, Torque 0-600 inch pounds, NSN 5120-00-288-8865

Personnel Required:

68D Aircraft Powertrain Repairer

Equipment Condition:Air supply off and air bled

WARNING

High pressure compressed air against skin or near eye can cause injury or blindness. Do not direct compressed air against skin or near eyes. Always wear safety goggles when working with compressed air. Ensure compressed air supply is disconnected and air bled before attempting this task.

INSPECTION

1. Check water/oil separator bracket (1) for security.

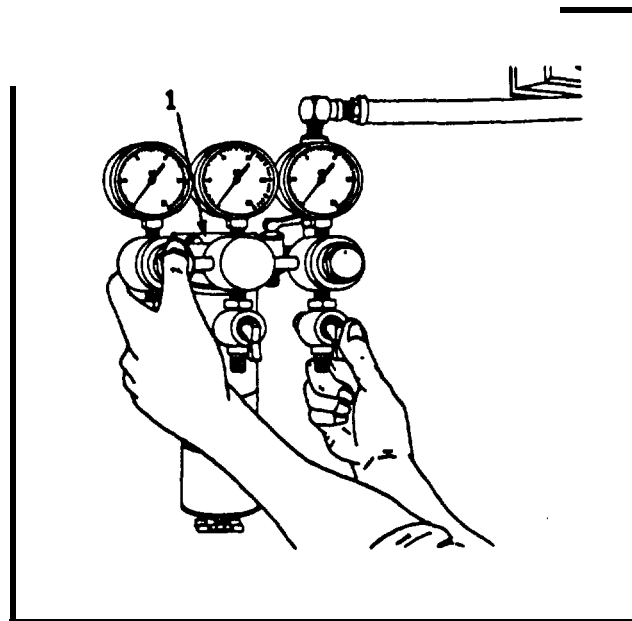

GO TO NEXT PAGE

3-11. Water/Oil Separator Mounting - Inspect (Cont)

- 2. Check torque (App G) on bolts (2) when bracket (1) is loose.
- 3. Remove bolts (2), lockwashers (3) and washers (4) when unable to tighten bolts (2) to specified torque (App G). Inspect bolts (2) and inserts IAW TASK 3-7.

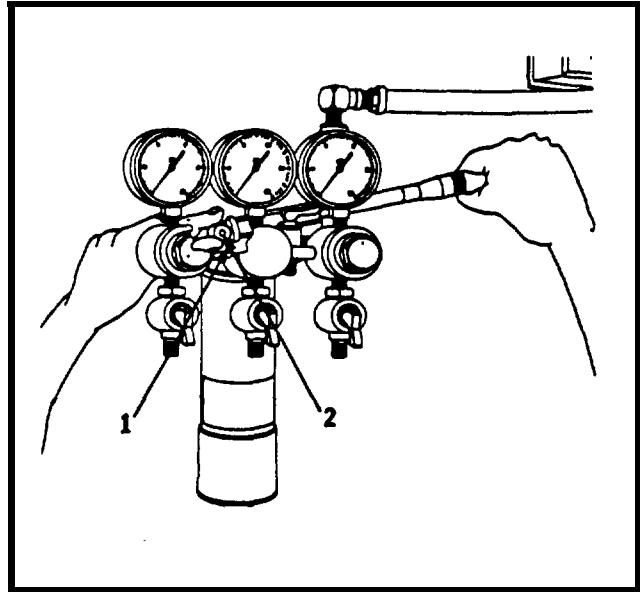

- 4. Position water/oil separator bracket (1) and align bolt holes with wall inserts. Install bolts (2), lockwashers (3), and washers (4) and torque (App G).

END OF TASK

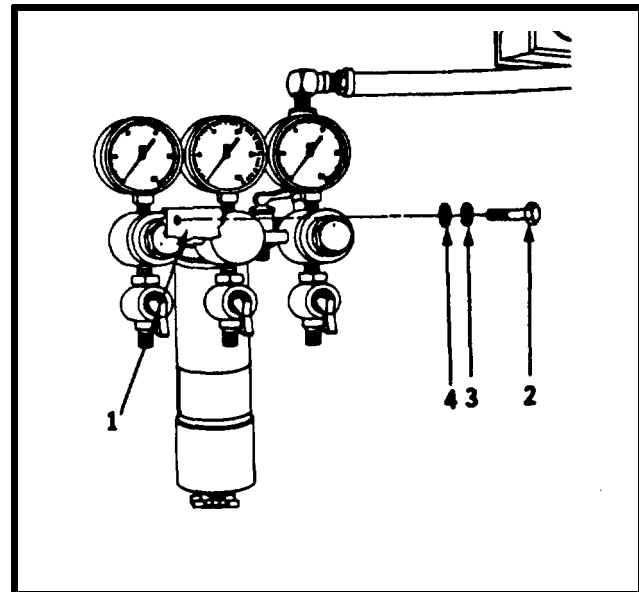

3-12. Water/Oil Separator Fittings and Air Hose -Inspect

3-12

This task covers: Inspection of fittings and air hose

INITIAL SETUPPersonnel Required:

68D Aircraft Powertrain Repairer

Equipment Condition:

Inspect Fittings: Air supply on

Inspect Air Hose: Air supply off and bled

INSPECT FITTINGS**WARNING**

High pressure compressed air against skin or near eye can cause injury or blindness. Do not direct compressed air against skin or near eyes. Always wear safety goggles when working with compressed air.

Inspect hose fitting (1), elbows (2), coupling (3), nipple (4) and bushing (5) for corrosion and leaks. Replace IAW Task 3-13 when corrosion and leaks exist.

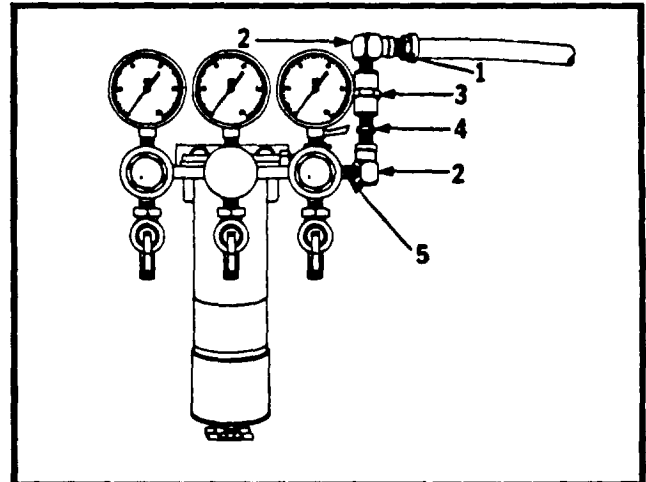

GO TO NEXT PAGE

INSPECT AIR HOSE

WARNING

High pressure compressed air against skin or near eye can cause injury or blindness. Do not direct compressed air against skin or near eyes. Always wear safety goggles when working with compressed air. Ensure compressed air supply is disconnected and air bled before attempting this task

Inspect air hose (1) for cracks or checking. Replace if visible IAW TASK 3-13.

END OF TASK

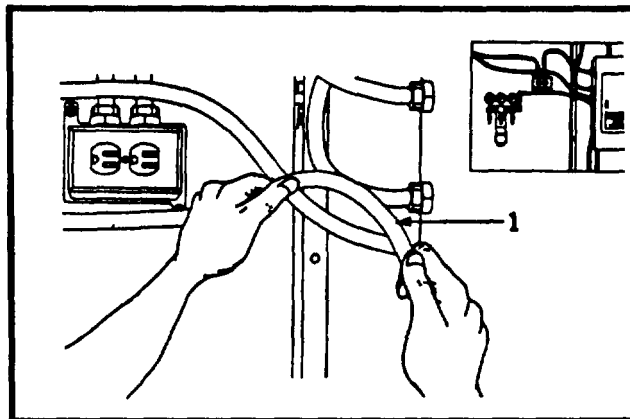

3-13. Water/Oil Separator Fittings and Air Hose - Replace

3-13

This task covers: Replacement of fittings and air hose

INITIAL SETUPTools:

Basic Issue Items (BII) - App C

Material:

Hose Assembly, NSN 4720-00-402-9511- App D

Personnel Required:

68D Aircraft Powertrain Repairer

Equipment Condition:

Air supply off and air bled

WARNING

High pressure compressed air against skin or near eye can cause injury or blindness. Do not direct compressed air against skin or near eyes. Always wear safety goggles when working with compressed air. Ensure air supply is disconnected and air bled before attempting this task.

REPLACE FITTINGS

1. Remove air hose from fitting. Retain as much of the hose as possible to permit reuse.
2. Remove hose fitting (1), elbows (2), coupling (3), nipple (4) and bushing (5) as necessary to gain access to defective part.
3. Replace defective part.
4. Install remaining hose fitting (1), elbows (2), coupling (3), nipple (4) and bushing (5) as necessary.
5. Install or replace air hose as appropriate

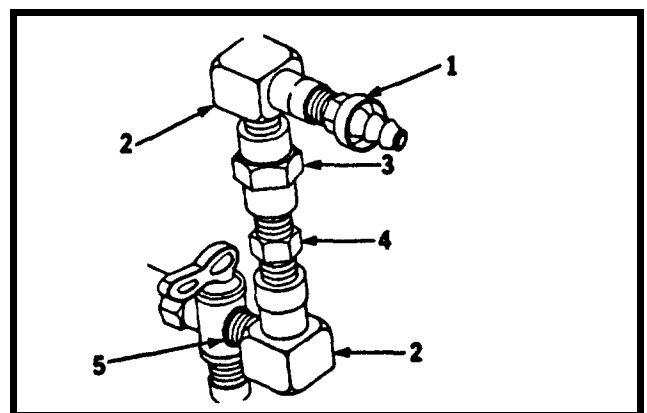

GO TO NEXT PAGE

3-13. Water/Oil Separator Fittings and Air Hose - Replace (Cont)

REPLACE AIR HOSE

1. Remove both loop clamps (1) from defective hose (2).

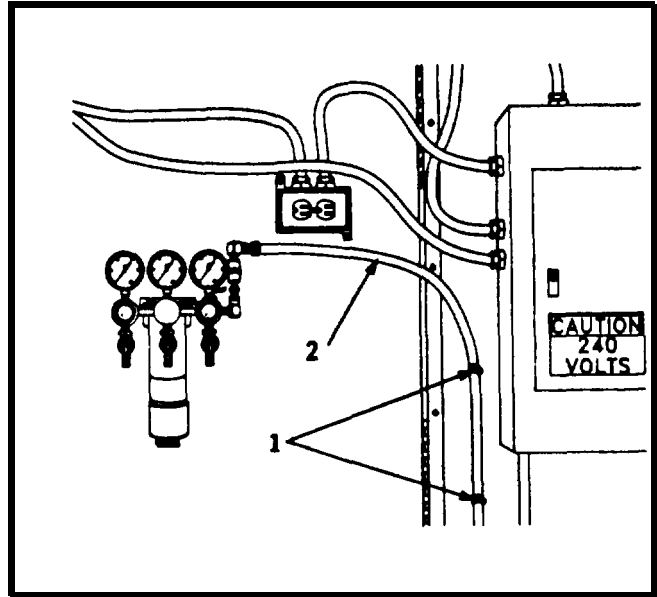

2. Slit hose (2) lengthwise from protective cap (3) to end of fitting (4) (approximately 1 1/2 inches) with knife.

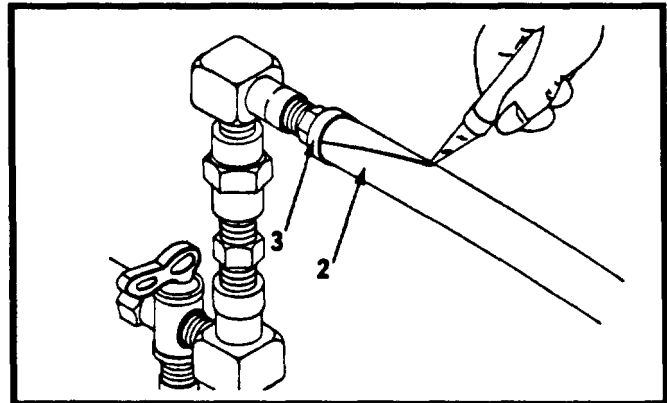

3. Bend hose (2) back over fitting (4) and snap off with quick tug.

4. Repeat Steps 2 and 3 at other end of hose.

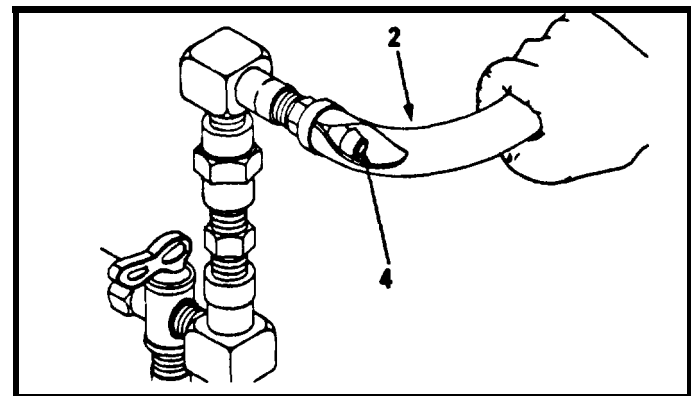

GO TO NEXT PAGE

3-13. Water/Oil Separator Fittings and Air Hose - Replace (Cont)

3-13

5. Slide loop clamps (1) over new hose (2).

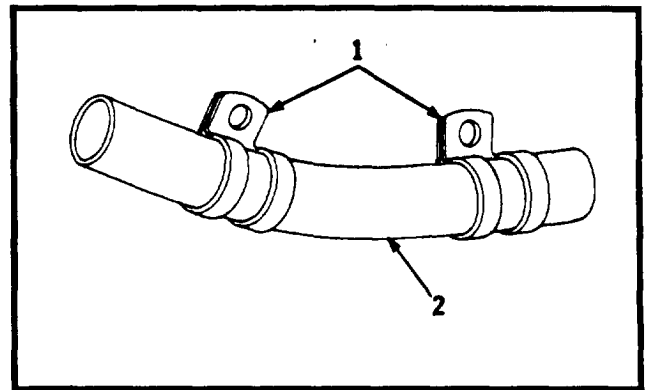

6. Replace fittings, if required, before proceeding to step 7.

7. Push hose (2) onto fitting (4) until end bottoms underneath protective cap (3).

8. Repeat Step 7 for other end of hose.

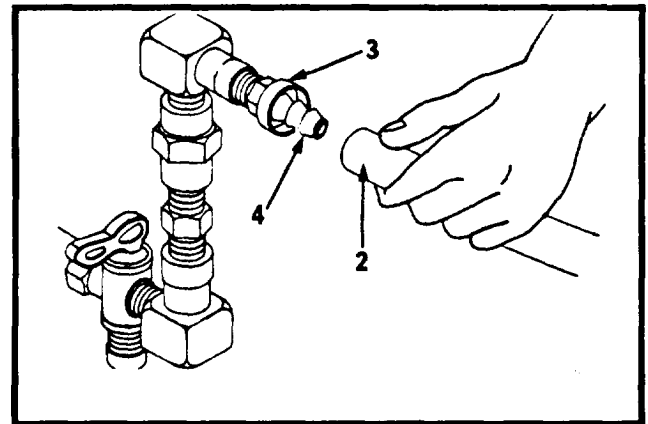

9. Install loop clamps (1) in original position and secure.

END OF TASK

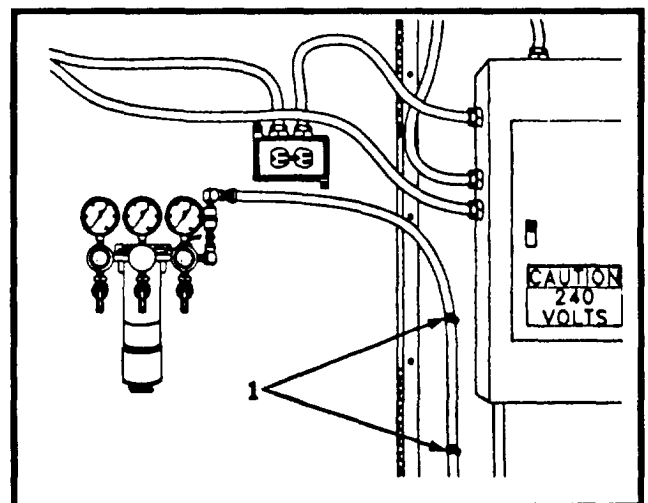

3-14. Fixtures - Water Feed Thru Connector- Inspect

3-14

This tasks covers: Inspection of connector

INITIAL SETUP

Personnel Required:

68D Aircraft Powertrain Repairer

INSPECT WATER FEED THRU CONNECTOR

1. Remove dust caps (1), faucet (2) or adapter (3) from connector (4).

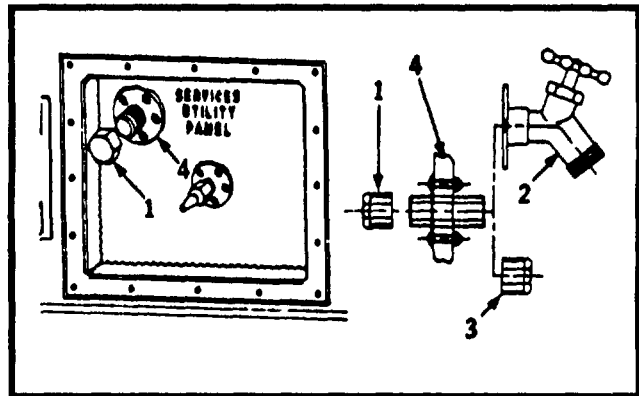

2. Inspect condition of connector threads (5). Inspect connector weld (6) for cracks or breaks. Replace IAW Task 3-15, if defective.

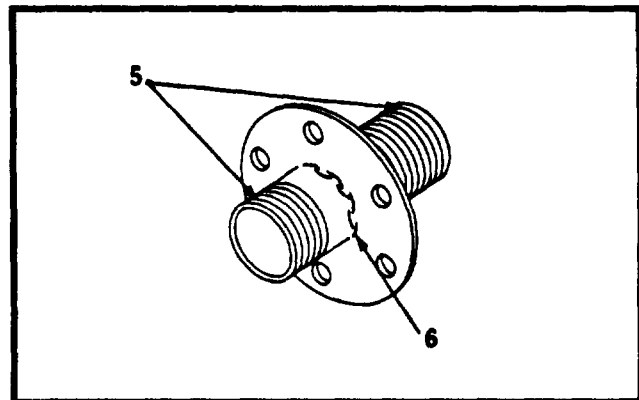

3. Install faucet (2) and adapter (3) as necessary.
4. Ensure dust caps (1) are installed when connector (4) is not in use.

END OF TASK

3-15. Fixtures - Water Feed Thru Connector - Replete

3-15

This task covers: Replacement of connector

INITIAL SETUPTools:

Basic Issue Items (BII) - App C

Material:

Feed thru connector - App F

Adhesive, NSN 8040-00-877-9872- App E

Personnel Required:

68D Aircraft Powertrain Repairer and Helper

Equipment Condition:

Faucet and adapters removed

REPLACE CONNECTOR

1. Remove six screws (1), lockwashers (2), washers (3) and nuts (4) securing connector (5).

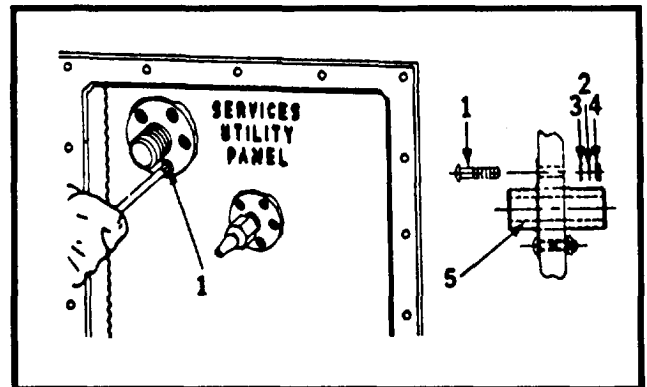

2. Remove connector (5) from panel and scrape off old adhesive.

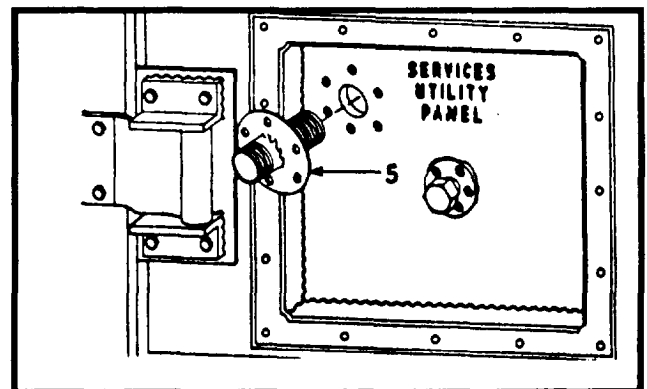

GO TO NEXT PAGE

3-15. Fixtures - Water Feed Thru Connector- Replace (Cont)

3. Manufacture new connector (5) IAW App F.
4. Apply adhesive (Item 2, App E) on side of connector collar (6) facing long end of connector (5).

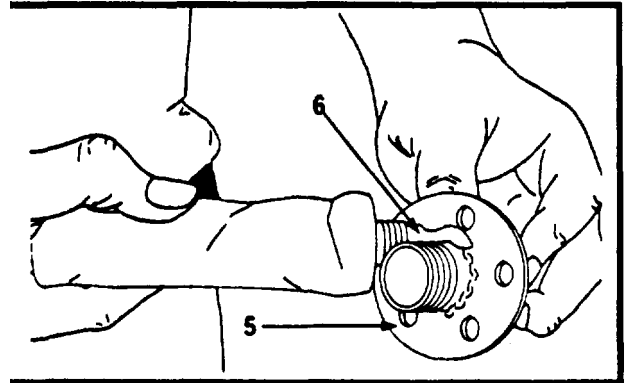

5. Install new connector (5) from outside of shelter; long end of nipple thru hole.

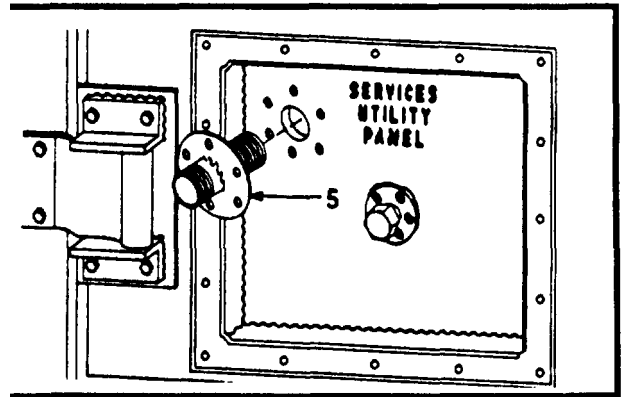

6. Install six screws (1), lockwashers (2), washers (3) and nuts (4).

END OF TASK

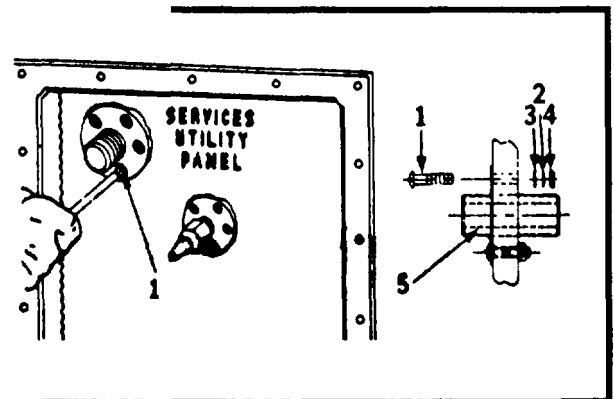

3-16. Fixtures - Air Feed Thru Connector - Inspect

3-16

This task covers: Inspection of connector

INITIAL SETUPPersonnel Required:

68D Aircraft Powertrain Repairer

INSPECT AIR FEED THRU CONNECTOR

1. Remove dust cap (1) or quick disconnect (2) from connector (3) at exterior service panel.

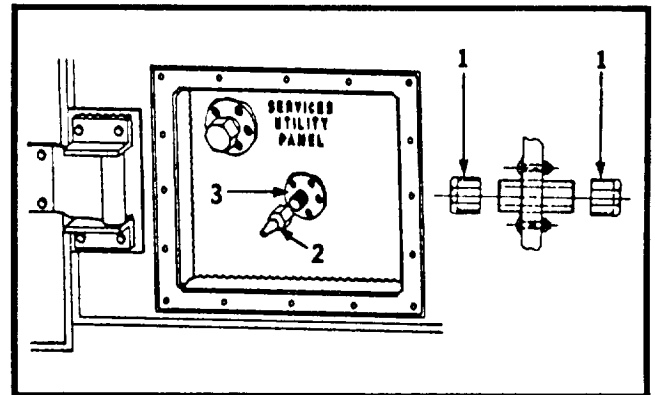

2. Inspect condition of connector threads (4). Inspect connector weld (5) for cracks or breaks. Replace IAW Task 3-17, if defective.

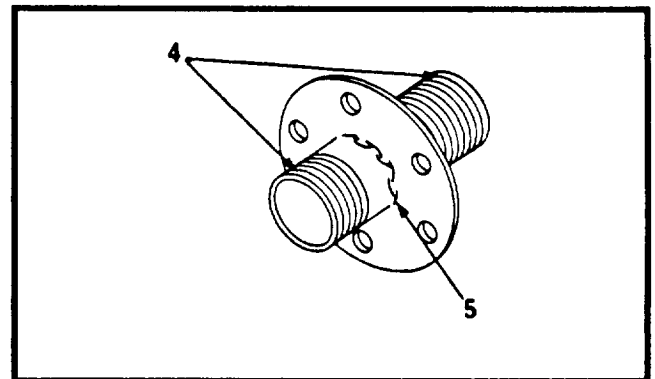

3. Install quick disconnect (2) as necessary.
4. Ensure dust cap (1) is installed when quick disconnect is not connected.

END OF TASK

3-17. Fixtures - Air Feed Thru Connector- Replace

3-17

This task covers: Replacement of connector

INITIAL SETUP

Tools:

Basic Issue Items (BII) - App C

Material:

Air Feed thru connector - App F

Adhesive, NSN 8040-00-877-9872- App E

Personnel Required:

68D Aircraft Powertrain Repairer and Helper

Equipment Condition:

All fittings and adapters removed

REPLACE CONNECTOR

1. Remove six screws (1), lockwashers (2), washers (3) and nuts (4) securing connector (5).

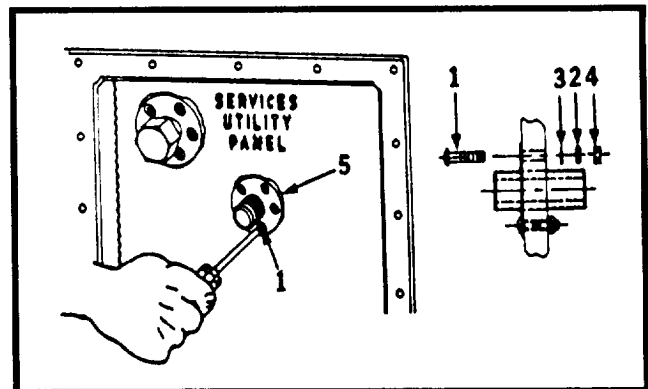

2. Remove connector (5) from wall and scrape off old adhesive.

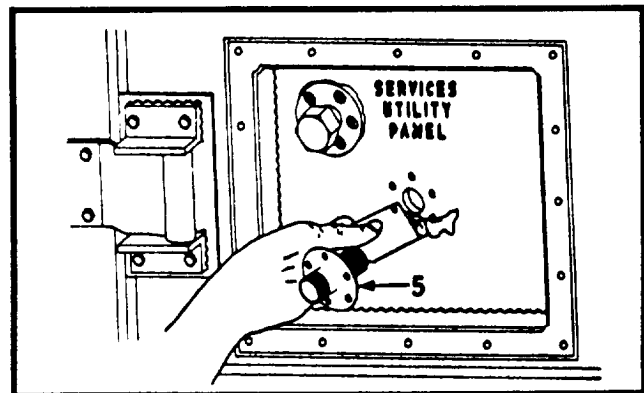

GO TO NEXT PAGE

3-17. Fixtures - Air Feed Thru Connector - Replace (Cont)

3-17

3. Manufacture new connector (5) IAW App F.
4. Apply adhesive (Item 2, App E) on flat side of connector collar (6) facing long end of connector (5).

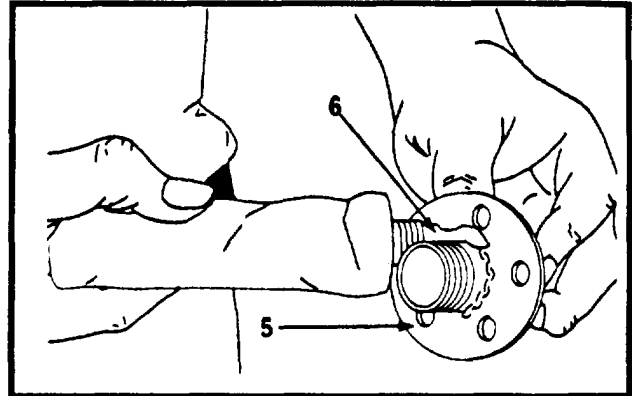

5. Install new connector (5) from outside of shelter inserting long end of nipple thru hole.

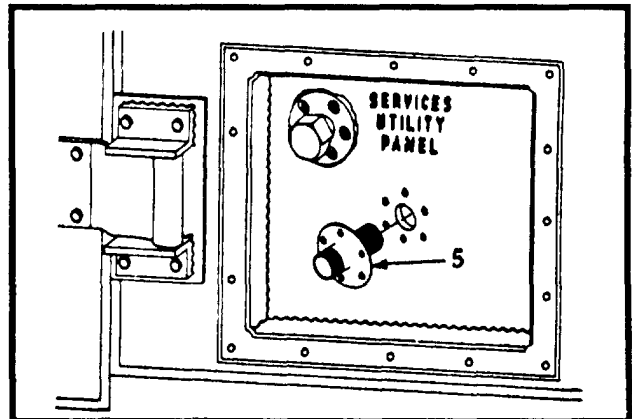

6. Install six screws (1), lockwashers (2), washers (3) and nuts (4).

END OF TASK

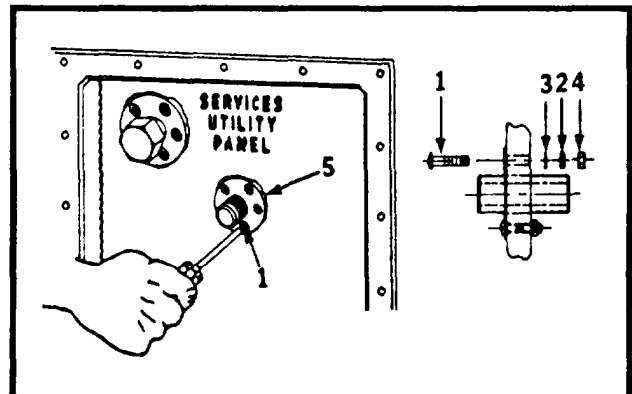

3-18. Ground Rod/Strap - Inspect

3-18

This task covers: Inspection of ground rod and strap

INITIAL SETUPTools:

Tool Kit, Electrical Repairer, Army Aircraft, NSN 5180-00-323-4915
Multimeter, NSN 6625-01-139-2512

Personnel Required:

68F Aircraft Electrician

Reference Information:

TC 11-6

INSPECTION**WARNING**

HIGH VOLTAGE exists in the electrical system of this shop. All electrical inspections, repairs or replacements shall be performed with the power OFF and only by qualified electricians. Serious shock hazards exist which could result in serious injury or death to personnel.

1. Check ground rod.
 - a. Ensure ground rod (1) is firmly driven into ground.
 - b. Ensure that Clamp (2) and screw (3) are securely fastened.
 - c. Ensure there is no sign of oxidation around clamp (2) or screw (3).
 - d. Ensure ground strap (4) is not frayed or broken.

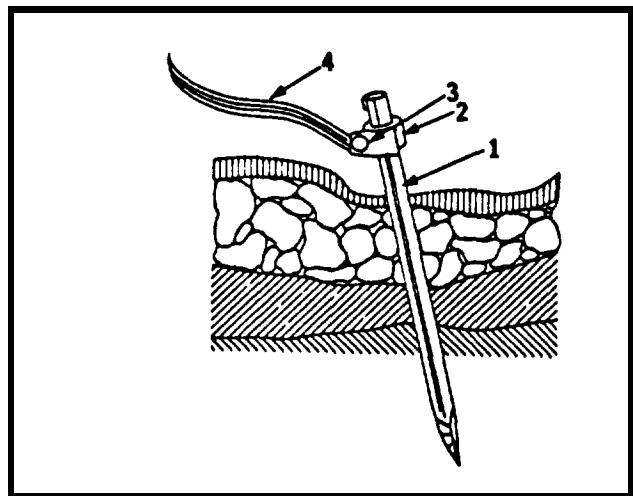

GO TO NEXT PAGE

3-18. Ground Rod/Strap - Inspect (Cont)

3-18

2. Check ground strap connection for security and corrosion at terminal lug (5) on power entry panel (6).

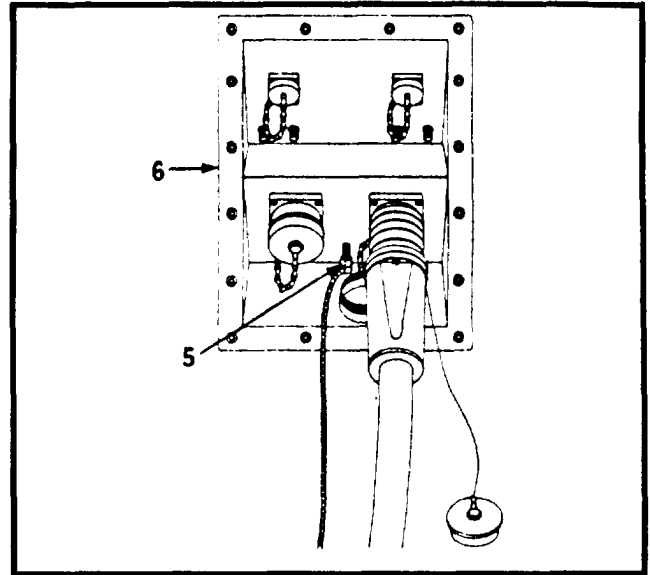

3. Check condition of ground using multimeter (7). (Use TC 11-6).

- a. Set multimeter (7) for AC voltage.

- b. Place red lead on shelter.

- c. Place black lead on ground strap.

- d. Measure Voltage:

- 0-5 Volts, adequate ground;

- Over 5 volts - poor ground, reinstall ground system.

END OF TASK

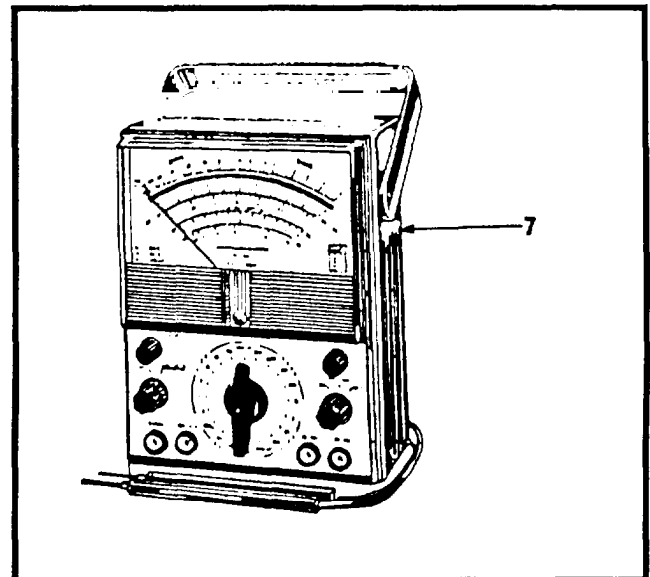

This task covers: Inspection of book rack

INITIAL SETUP

Tools:

Basic Issue Items (BII) - App C

Wrench, Torque 0-600 inch pounds, NSN 5120-00-288-8865

Personnel Required:

68D Aircraft Powertrain Repairer

NOTE

The inspection task for the book rack is presented as a guide for inspection tasks for the remainder of the fabricated components.

INSPECTION

1. Ensure book rack (1) is secure on shelter wall.

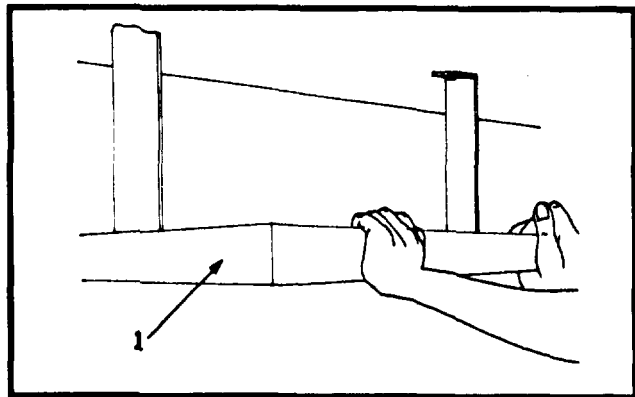

2. Check torque (App G) on bolts (2) when book rack is loose.

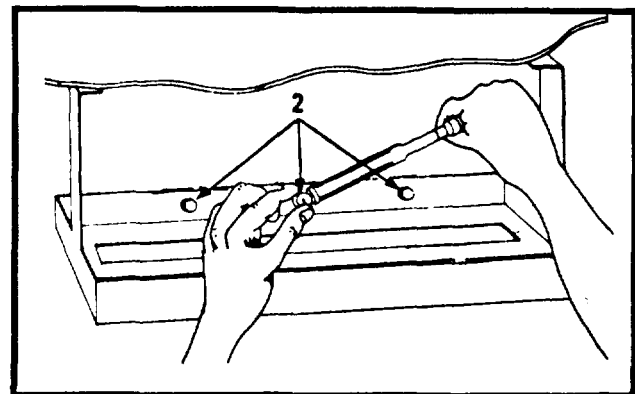

GO TO NEXT PAGE

3-19. Special Brackets and Fabricated Components, Book Rack - Inspect (Cont)

3-19

3. Remove bolts (2), lockwashers (3), washers (4) and book rack (1) when bolts (2) will not tighten to specified torque (App G). Inspect bolts (2) and inserts IAW TASK 3-7.

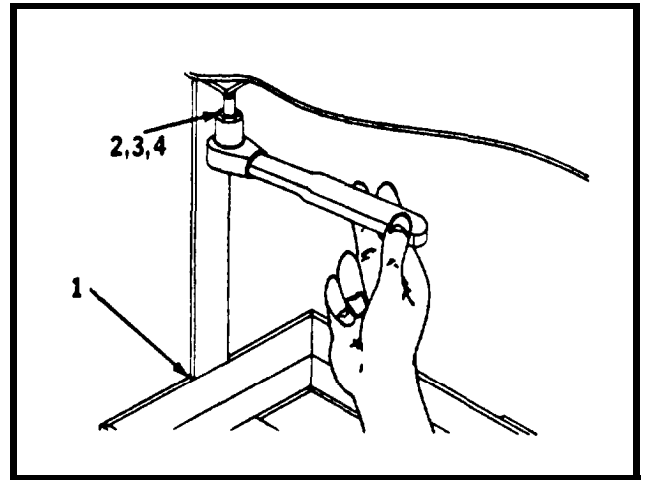

4. Inspect book rack (1) for bends, cracks or broken welds.
5. Make necessary repairs to book rack IAW TASK 3-20.

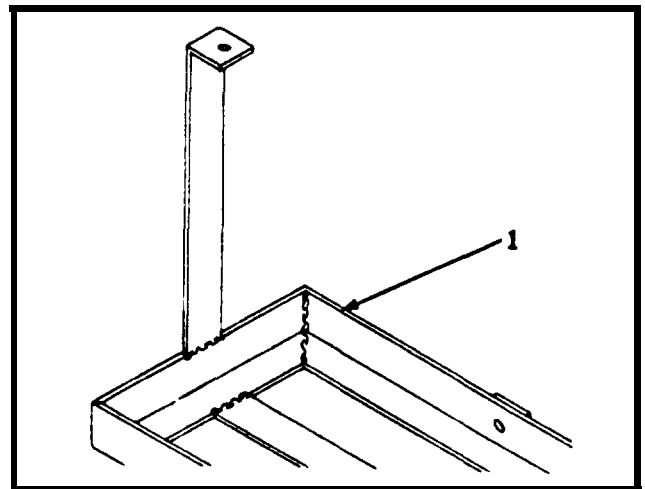

GO TO NEXT PAGE

6. Install book rack (1).

a. Position book rack (1) on wall alining holes (5) with inserts (6).

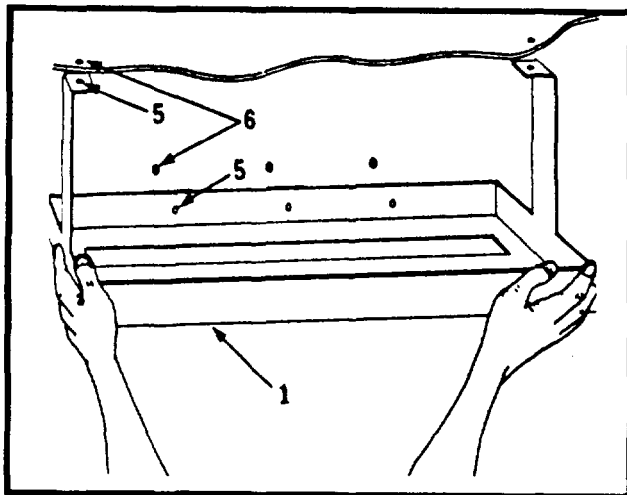

b. Install bolts (2), lockwashers (3) and washers (4), and torque (App G).

END OF TASK

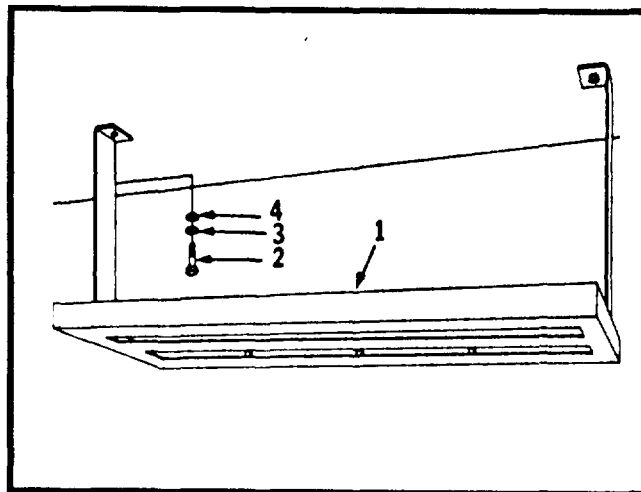

3-20. Special Brackets and Fabricated Components, Book Rack - Repair

3-20

This tasks covers: Repair of book rack

INITIAL SETUP

Tools:

Basic Issue Items (BII) - App C
Wrench, Torque 0-600 inch pounds, NSN 5120-00-288-8865
Shop Set, Machine, NSN 4920-00-405-9279
Shop Set, Welding, NSN 4920-00-163-5093

Material:

Rod, welding - App E
Primer coating, NSN 8010-00-297-0593- App E
Enamel, white, NSN 8010-00-159-4520- App E
Enamel, gray, NSN 8010-00-852-9034 -App E

Personnel Required:

68D Aircraft Power Train Repairer

Reference Information:

TM 55-1500-204-25/1
MIL-W-8604A
TM 43-0139

NOTE

The repair task for the book rack is presented as a guide for repair tasks for the remainder of the fabricated components.

REPAIR

Warning

Extreme care must be taken when performing. all types of welding operations. Serious health and fire hazards exist. Harmful light rays can cause eye injury or blindness. Protective face masks and goggles must be used as well as other special clothing to reduce risks, Poisonous fumes, burns, electric shock, fire and explosion hazards are some of the additional possibilities of injury associated with welding operations. It is essential that all safe practices be strictly observed.

GO TO NEXT PAGE

1. Remove five bolts(1), lockwashers (2), and washers (3) securing book rack (4) to wall. Remove book rack (1).

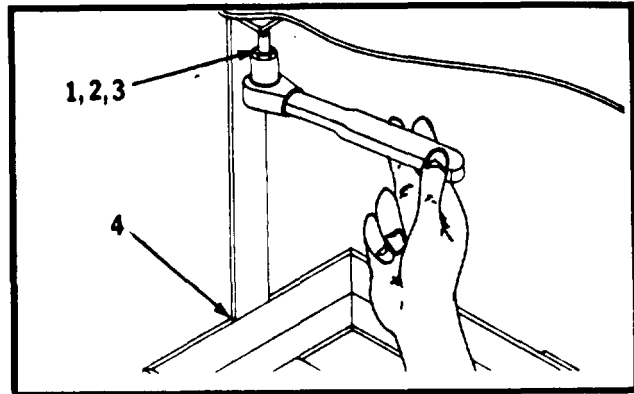

2. Repair cracks or breaks in book rack (4) or welds (5) by welding IAW TM 55-1500-204-25/1 and MIL-W-8604A (Use welding rod, item 7, App E, or equivalent).

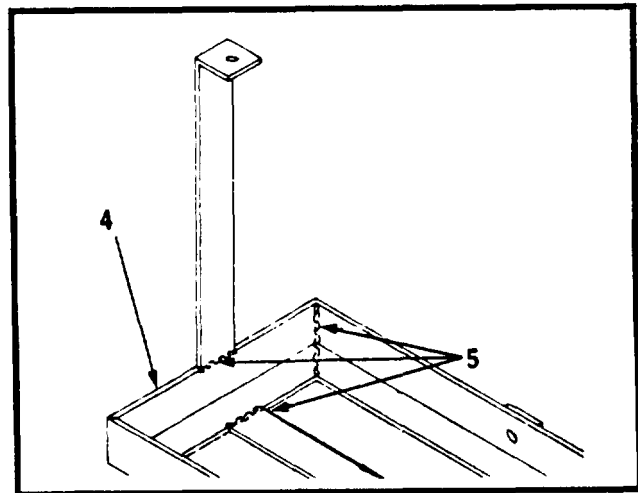

NOTE

Replacement of book rack is required when any repairs result in a change to the original design or dimensions of the book rack. See TASK 3-21.

3. Touch up bare metal as necessary with primer (item 6, App E).
4. Touch up painted surface as necessary with enamel (item 4,5, App E).

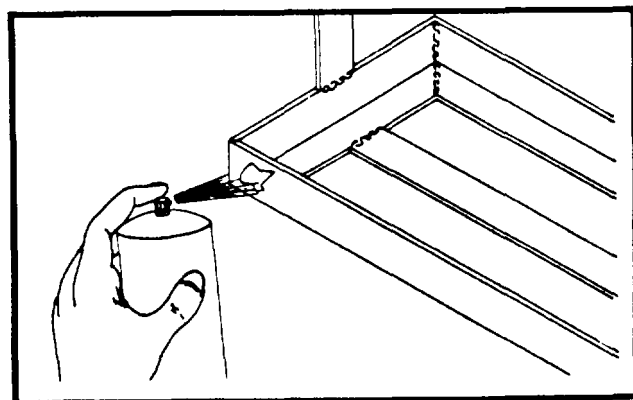

GO TO NEXT PAGE

3-20. Special Brackets and Fabricated Components, Book Rack - Repair (Cont)

3-20

5. Position book rack (4) on wall alining holes (5) with inserts (6).

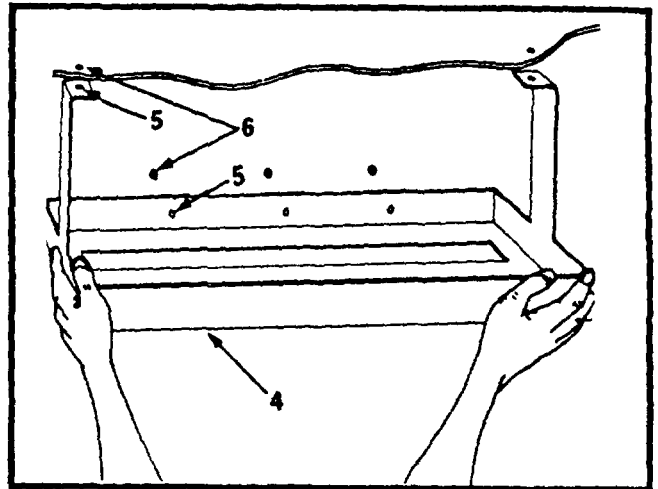

6. Install five bolts (1), lockwashers (2), and washers (3) in book rack (4), and torque (App G).

END OF TASK

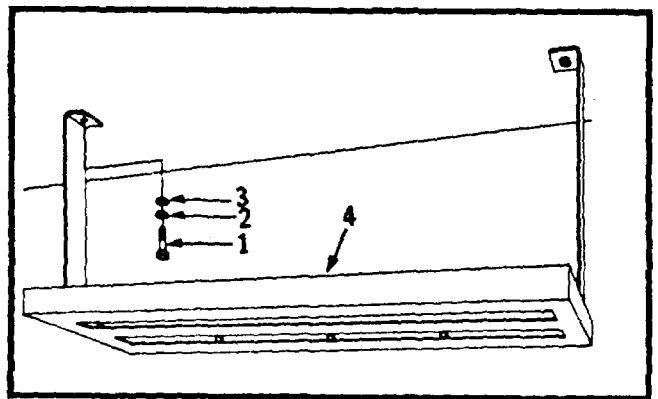

3-21. Special Brackets and Fabricated Components, Book Rack - Replace

3-21

This tasks covers: Replacement of book rack

INITIAL SETUP

Tools:

Basic Issue Items (BII) - App C

Wrench, Torque 0-600 inch pounds, NSN 5120-00-288-8865

■ Shop Set, Machine, NSN 4920-00-405-9279

Shop Set, Welding, NSN 4920-00-163-5093

Personnel Required:

68D Aircraft Power Train Repairer

Reference Information:

TM 55-1500-204-25/1

NOTE

The replace task for the book rack is presented as a guide for replace tasks for the remainder of the fabricated components.

REPLACEMENT

1. Remove five bolts (1), lockwashers (2) and washers (3) from book rack (4). Remove book rack (4).
2. Fabricate new book rack IAW App F.

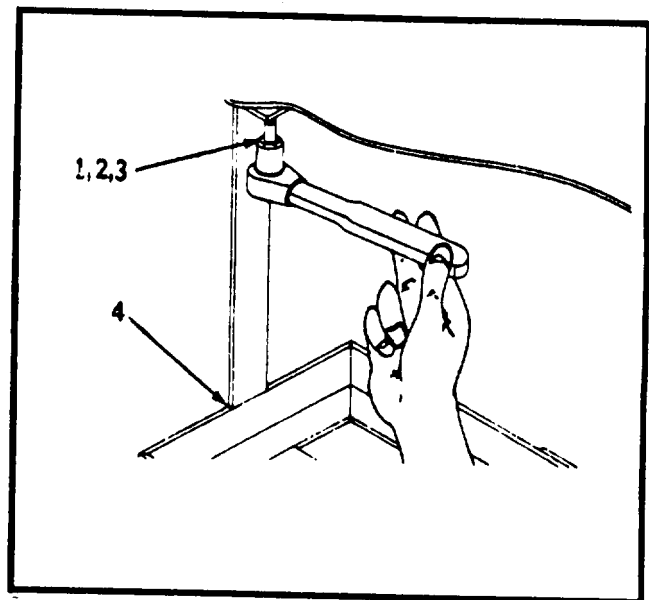

GO TO NEXT PAGE

3-21. Special Brackets and Fabricated Components, Book Rack - Replace (Cont)

3-21

3. Position bookrack (4) on wall alining holes (5) with inserts (6).

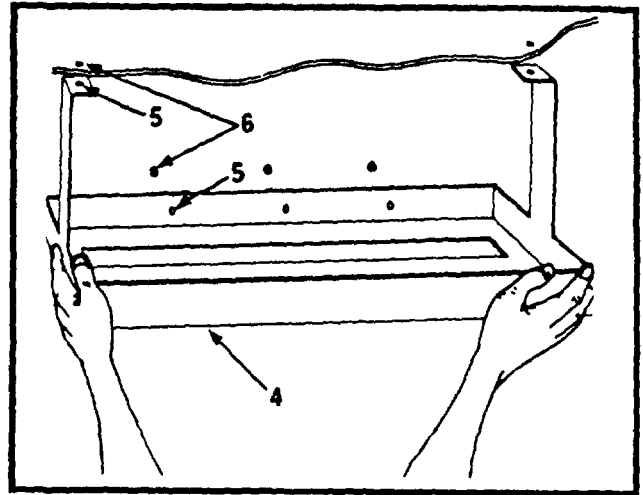

4. Install five bolts (1), lockwashers (2) and washers (3), and torque (App G).

END OF TASK

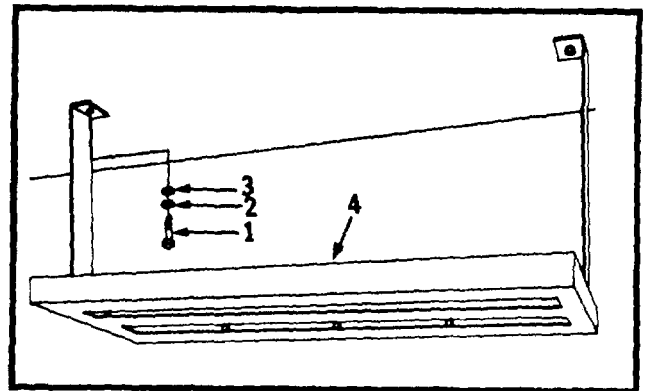

3-22. Floor Plugs - Inspect

3-22

This task covers: Inspection of floor plugs

INITIAL SETUP

Tools:

Basic Issue Items (BII) App - C

Personnel Required:

68D Aircraft Powertrain Repairer

INSPECTION

1. Inspect floor plugs (1) for damaged or broken threads prior to installation and upon removal.

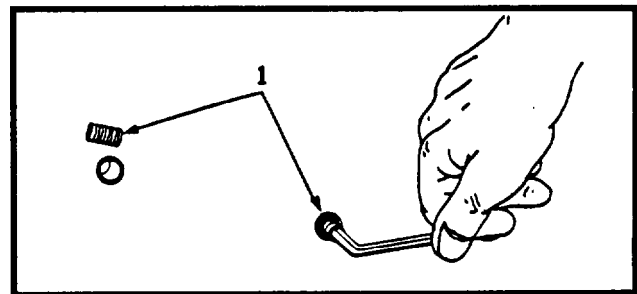

2. Replace floor plugs (1) as necessary.

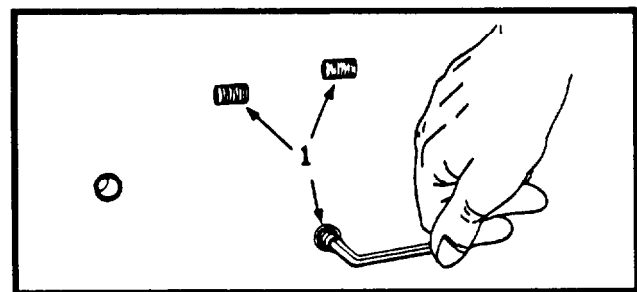

3. Inspect inserts (2) LAW Task 3-7.

END OF TASK

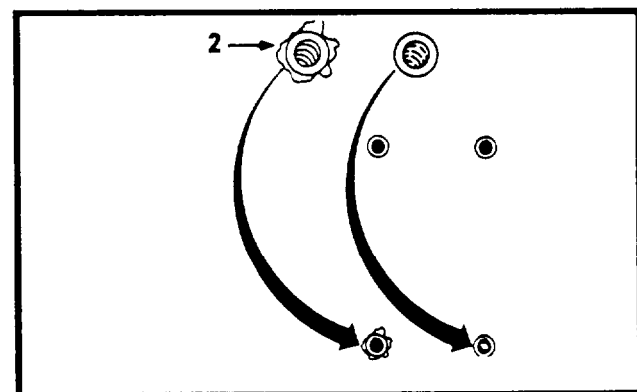

3-23. Fixed Equipment/Components - Removal/Installation

3-23

This task covers: Removal/Installation of fixed equipment/components

INITIAL SETUPTools:

Shop Set, Tool Crib, NSN 4920-00-472-4183

Personnel Required:

68D Aircraft Powertrain Repairer

REMOVAL/INSTALLATION**1. REMOVE/INSTALL FIXED EQUIPMENT.****NOTE**

Permanently installed equipment should not ordinarily be removed or re-located. However, in the event that it becomes necessary to remove, re-install or replace fixed equipment within the shelter, care must be taken to remove all bolts, washers and nuts and save them for reuse.

- a. Remove all bolts (1), lockwashers (2), washers (3) and nuts (4) from shop equipment. Remove equipment.
- b. Install new or repaired equipment. If new equipment has different mounting brackets, remount equipment as follows:
 1. Mark new mounting location on bench top.
 2. Drill holes.
 3. Align shop equipment,
- c. Install bolts (1), lockwashers (2) washers (3) and nuts (4).

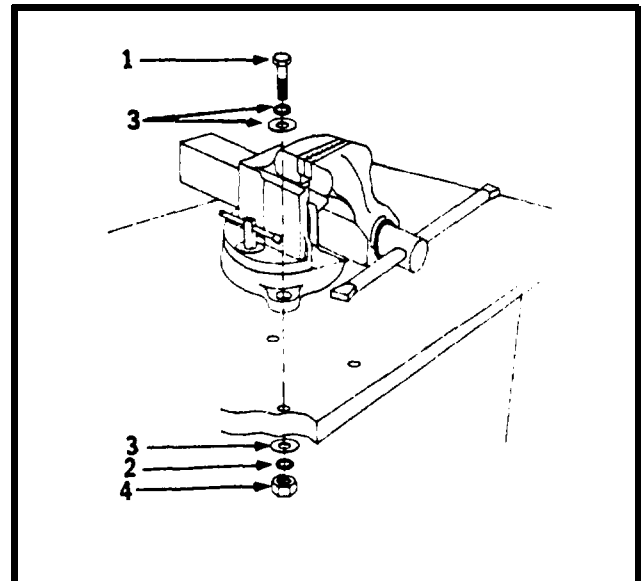

GO TO NEXT PAGE

2. REMOVE/INSTALL BENCH TOP.

NOTE

Permanently installed bench tops should not ordinarily be removed or relocated. However, in the event that it becomes necessary to remove, reinstall or replace them within the shelter, care must be taken to remove all bolts, washers and nuts and save them for reuse. Two types of bench tops are installed throughout the shop sets: 1) 30 inch width; 2) 60 inch width. These tops together with open bench legs are attached in several configurations to the cabinets in the shop sets.

- a Remove all shop equipment from bench top IAW Step 1.a.
- b. Remove all lag bolts (1), lockwashers (2) and washers (3) attaching bench top to cabinet
- c. Remove bench top (4).

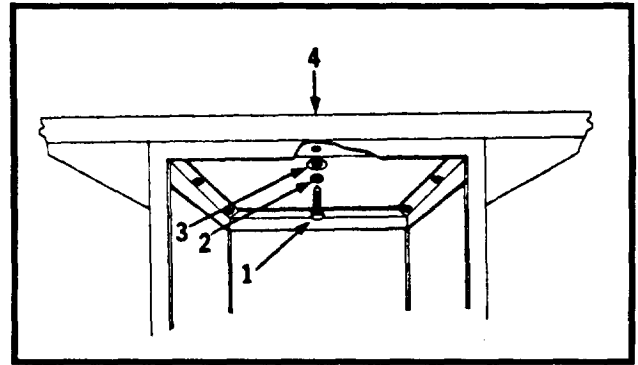

- d If new bench top (4) is to be installed, proceed as follows, otherwise proceed to Step e.
- 1) Obtain all mounting hole locations and dimensions from old bench top (4).
- 2) Mark new bench top (4) for drilling using locations and dimensions obtained in Step 2.d.1.
- 3) Drill holes.

- e. Align bench top (4) on cabinet and install lagbolts (1), lockwashers (2) and washers (3).
- f. Align shop equipment over mounting holes and install fastening hardware.

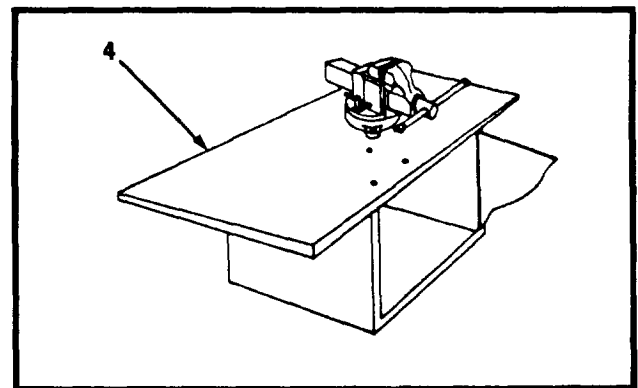

GO TO NEXT PAGE

3-23. Fixed Equipment/Components - Removal/Installation (Cont)

3-23

3. REMOVE/INSTALL CABINETS.

NOTE

Permanently installed cabinets should not ordinarily be removed or relocated. However, in the event that it becomes necessary to remove, reinstall or replace cabinets within the shelter, care must be taken to remove all bolts, lockwashers, washers and nuts and save them for reuse. Cabinets are bolted to the floor, wall, and adjacent cabinets. Four cabinet styles are installed throughout the shop sets and may be complexed in various configurations. All mounting holes are universal and cabinets may be substituted for others without special mounting considerations.

- a Remove fixed equipment end bench tops as required.
- b. Remove all bolts (1), lockwashers (2) and washers (3) from cabinets. Remove cabinets (4).
- c. Reposition cabinets (4).
- d Install bolts (1), lockwashers (2) and washers (3).

END OF TASK

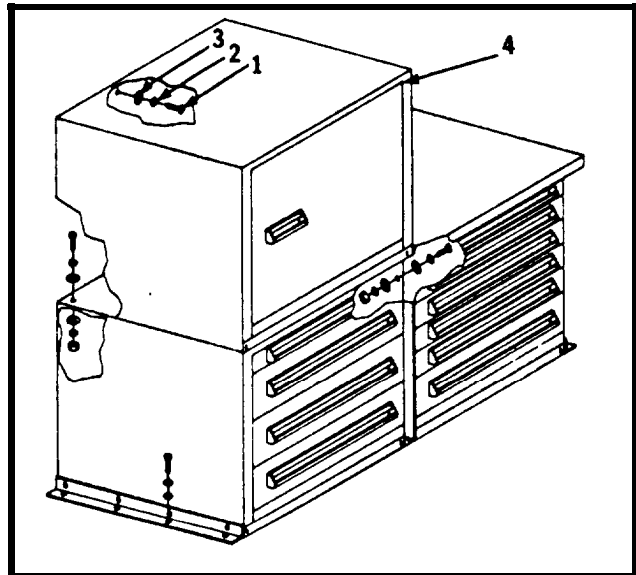

APPENDIX A REFERENCES

A-1. Dictionaries of Terms and Abbreviations.

AR 310-25..... Dictionary of United States Army Terms
AR310-50..... Authorized Abbreviations and Brevity Codes

A-2. Publication Indexes.

DA PAM 25-30..... Consolidated Index of Army Publications and Blank Forms

A-3. Logistics and Storage.

TM 743-200-1..... Storage and Material Handling

A-4. Maintenance of Supplies and Equipment.

AR 750-1.....Army Maintenance Material Concepts and Policies
TM 5-4120-384-14.....Air Conditioner, Horizontal, Compact, 18,000 BTU
TM 5-6150-226-13&P .. Distribution Illumination System, Electrical (DISE)
TM 10-5411-201-14..... Shelter. Tactical Expandable, One Side NSN 5411-01-124-1377
TM 43-0139.....Painting Operations Instructions for Field Use
TM 55-1500-204-25/1 .. General Aircraft Maintenance Manual

A-5. Other Publications

AR 420-90.....Fire Prevention and Protection
AR 55-38.....Reporting of Transportation Discrepancies in Shipments
AR 700-58.....Packaging Improvement Report
DA PAM 310-13.....Military Publications Posting and Filing
DA PAM 738-751..... Functional users Manual for The Army Maintenance Management System-Aviation
(TAMMS-A)
FM21-11.....First Aid for Soldiers
MIL-W-8604A.....Welding, Fusion, Aluminum Alloy Process and Performance
TC 11-6.....Grounding Techniques
TB 43-180.....Calibration Requirements for the Maintenance Army Material
TM 750-244- 1-4..... Procedures for the Destruction of Aviation Ground Support Equipment (FSC 4920)
to prevent Enemy Use

APPENDIX B MAINTENANCE ALLOCATION CHART

SECTION I. INTRODUCTION

B-1. General.

a. This section provides a general explanation of all maintenance repair functions authorized at various maintenance categories.

b. The Maintenance Allocation Chart (MAC) in section II designates overall authority and responsibility for the performance of maintenance functions on the identified end item or component. The application of the maintenance functions to the end item or component will be consistent with the capacities and capabilities of the designated maintenance categories.

c. Section III lists the tools and test equipment (both special tools and common tool sets) required for each maintenance function as referenced from Section II.

d. Section IV contains supplemental instructions and explanatory notes for a particular maintenance function.

B-2. Maintenance Functions. Maintenance functions will be limited to and defined as follows:

a. Inspect. To determine the serviceability of an item by comparing its physical, mechanical and/or electrical characteristics with established standards through examination (e.g., by sight, sound, or feel).

b. Test. To verify serviceability by measuring the mechanical, pneumatic, hydraulic, or electrical characteristics of an item and comparing those characteristics with prescribed standards.

c. Service. Operations required periodically to keep an item in proper operational condition, i.e., to clean (includes decontaminate, when required), to preserve, to drain, to paint, or to replenish fuel, lubricants, hydraulic fluids, or gases.

d. Adjust. To maintain or regulate, within prescribed limits, by bringing into proper or exact position, or by setting the operating characteristics to the specified parameters.

e. Align. To adjust specified variable elements of an item to bring about optimum or desired performance.

f. Calibrate. To determine and cause corrections to be made or to be adjusted on instruments or test measuring and diagnostic equipments used in precision measurement. Consists of comparisons of two instruments, one of which is a certified standard of known accuracy, to detect and adjust any discrepancy in the accuracy of the instrument being compared.

g. Remove/Install. To remove and install the same item when required to perform service or other maintenance functions. Install may be the act of emplacing, seating, or fixing into position a spare, repair part, or module (component or assembly) in a manner to allow the proper functioning of an equipment or system.

h. Replace. To remove an unserviceable item and install a serviceable counterpart in its place. "Replace" is authorized by the MAC and is shown as the d position code of the SMR code.

i. Repair. The application of maintenance services including fault location/troubleshooting, removal/installation, and disassembly/assembly procedures, and maintenance actions to identify troubles and restore serviceability to an item by correcting specific damage, fault, malfunction, or failure in a part, subassembly, module (component or assembly), end item, or system.

j. Overhaul. The maintenance effort (service/action) prescribed to restore an item to a completely serviceable/operational condition as required by maintenance standards in appropriate technical publications (i.e., DMWR). Overhaul is normally the highest degree of maintenance performed by the Army. Overhaul does not normally return an item to like new condition.

k. Rebuild. Consists of those service/actions necessary for the restoration of unserviceable equipment to a like new condition in accordance with original manufacturing standards. Rebuild is the highest degree of material maintenance applied to Army equipment. The rebuild operation includes the act of returning to zero those age measurements (hours, miles, etc.) considered in classifying Army equipments/components.

B-3. Explanation of Columns In the MAC, Section II.

a. Column 1, Group Number. Column 1 lists functional group code numbers, the purpose of which is to identify maintenance significant components, assemblies, subassemblies, and modules with the next higher assembly. End item group number shall be "00."

b. Column 2, Component/Assembly. Column 2 contains the names of components, assemblies, subassemblies, and modules for which maintenance is authorized.

c. Column 3, Maintenance Function. Column 3 lists the functions to be performed on the item listed in Column 2. (For detailed explanation of these functions, see paragraph B-2.).

d. Column 4, Maintenance Category. Column 4 specifies, by the listing of a work time figure in the appropriate subcolumn(s), the category of maintenance authorized to perform the function listed in Column 3. This figure represents the active time required to perform that maintenance function at the indicated category of maintenance. If the number or complexity of the tasks within the listed maintenance function vary at different maintenance categories, appropriate work time figures will be shown for each category. The work time figure represents the average time required to restore an item (assembly, subassembly, component, module, end item, or system) to a serviceable condition under typical field operating conditions. This time includes preparation time (including any necessary disassembly/assembly time), troubleshooting/fault location time, and quality assurance/quality control time in addition to the time required to perform the specific tasks identified for the maintenance functions authorized in the maintenance allocation chart. The symbol designations for the various maintenance categories are as follows:

AVUM	Aviation Unit Maintenance
AVIM	Aviation Intermediate Maintenance
DEPOT	Depot Maintenance

e. Column 5, Tools and Equipment. Column 5 specifies, by code, those common tool sets (not individual tools) and special tools, TMDE, and support equipment required to perform the designated function.

f. Column 6, Remarks. This column shall, when applicable, contain a letter code, in alphabetic order, which shall be keyed to the remarks contained in Section IV.

B-4. Explanation of Columns In Tool and Test Equipment Requirements, Section III.

a. Column 1, Reference Code. The tool and test equipment reference code correlates with a code used in the MAC, Section II, Column 5.

b. Column 2, Maintenance Category. The lowest category of maintenance authorized to use the tool or test equipment.

c. Column 3, Nomenclature. Name or identification of the tool or test equipment.

d. Column 4, National Stock Number. The national stock number of the tool or test equipment.

e. Column 5, Tool Number. The manufacturer's part number.

B-5. Explanation of Columns In Remarks, Section IV.

a. Column 1, Reference Code. The code recorded in column 6, Section II.

b. Column 2, Remarks. This column lists information pertinent to the maintenance function being performed as indicated in the MAC, Section II.

SECTION II. MAINTENANCE ALLOCATION CHART

(1) GROUP NUMBER	(2) COMPONENT/ASSEMBLY	(3) MAINTENANCE FUNCTIONS	(4) MAINTENANCE CATEGORY			(5) TOOLS AND EQPT	(6) REMARKS
			AVUM	AVIM	DEPOT		
01	FASTENERS						
0101	BOLTS	INSPECT REPLACE		.2 .5		3,6 3,6	A, B, C A, B, C
0102	INSERTS, POTTED	INSPECT REPLACE		.2 1.5		3,6 3,6	A, B, C D
0103	INSERTS, NON-POTTED	INSPECT REPLACE		.2 1.5		3,6 3,6	A, B, C D
02	FIXTURES						
0201	FIRE EXTINGUISHER MOUNTING	INSPECT		.1		3,6	B
0202	WATER/OIL SEPARATOR MOUNTING	INSPECT		.1		3,6	A,B
0203	WATER/OIL SEPARATOR FITTINGS AND AIR HOSE ASSY	INSPECT REPLACE		.1 1.0		6	
0204	WATER FEED THRU CON- NECTOR	INSPECT REPLACE		.2 1.0		6	
0205	AIR FEED THRU CONNec- TOR	INSPECT REPLACE		.2 1.0		6	
03	ELECTRICAL						
0301	GROUND ROD/STRAP	INSPECT		.2		1,5	E

SECTION II. MAINTENANCE ALLOCATION CHART - Continued.

(1) GROUP NUMBER	(2) COMPONENT/ASSEMBLY	(3) MAINTENANCE FUNCTIONS	(4) MAINTENANCE CATEGORY			(5) TOOLS AND EQPT	(6) REMARKS
			AVUM	AVIM	DEPOT		
04	SPECIAL BRACKETS AND FABRICATED COM- PONENTS						
0401	BRACKET, CABINET	INSPECT REPAIR REPLACE		.1 .5 .3		3,6 2,3,4,6 2,3,4,6	C C
0402	BRACKET ASSEMBLY, STORAGE CHEST	INSPECT REPAIR REPLACE		.2 1.2 .3		3,6 2,3,4,6 2,3,4,6	C C
0403	RACK ASSEMBLY, BOOK	INSPECT REPAIR REPLACE		.1 1.0 .5		3,6 2,3,4,6 2,3,4,6	C C
0404	RACK ASSEMBLY, FIRST AID KIT	INSPECT REPAIR REPLACE		.1 1.0 .5		3,6 2,3,4,6 2,3,4,6	C C
0405	RACK ASSEMBLY, TOOL BOX	INSPECT REPAIR REPLACE		.3 2.0 .7		3,6 2,3,4,6 2,3,4,6	B, C B, C
0406	FRAME ASSEMBLY, ECU SUPPORT	INSPECT REPAIR REPLACE		.2 1.0 .2		3,6 2,3,4,6 2,3,4,6	c c
0407	SECURITY SCREEN, ECU	INSPECT REPAIR REPLACE		.2 1.5 .2		3,6 2,3,4,6 2,3,4,6	c c
05	FLOOR PLUGS	INSPECT		.1		6	

SECTION III. TOOL AND TEST EQUIPMENT

(1) TOOL OR TEST EQPT REF CODE	(2) MAINTENANCE CATEGORY	(3) NOMENCLATURE	(4) NATIONAL STOCK NUMBER
1	INTERMEDIATE	MULTIMETER	6625-01-139-2512
2	INTERMEDIATE	SHOP SET, MACHINE	4920-00-405-9279
3	INTERMEDIATE	SHOP SET, TOOL CRIB	4920-00-472-4183
4	INTERMEDIATE	SHOP SET, WELDING	4920-00-163-5093
5	INTERMEDIATE	TOOL KIT, ELECTRICAL REPAIRER	5180-00-323-4915
6	INTERMEDIATE	ARMY AIRCRAFT BASIC ISSUE ITEMS (BII)	

SECTION IV. REMARKS

(1) REFERENCE CODE	(2) REMARKS
A.	TORQUE VALUE ON 1/4" BOLTS IS 50-70 INCH POUNDS.
B.	TORQUE VALUE ON 5/16" BOLTS IS 100-140 INCH POUNDS.
C.	TORQUE VALUE ON 3/8" BOLTS IS 160-190 INCH POUNDS.
D.	FOLLOW PROCEDURES IN TM 10-5411-201-14.
E.	ELECTRICAL AND GROUND CHECKS TO BE MADE BY QUALIFIED ELECTRICIAN.

APPENDIX C

COMPONENTS OF END ITEM AND BASIC ISSUE ITEMS LIST

SECTION I. INTRODUCTION

C-1. SCOPE. This appendix lists Components of End Items (COEI) and Basic Issue Items (BII) for the Rotor Shop to help you inventory items required for safe and efficient operation.

C-2. GENERAL. The components of End Item and Basic Issue Items Lists are divided into the following sections:

a. SECTION II. Components of End Item. This listing is for informational purposes only, and is not authority to requisition replacements. These items are part of the end item, but are not removed and separately packaged for transportation or shipment. As part of the end item, these items must be with the end item whenever it is issued or transferred between property accounts. Illustrations are furnished to assist you in identifying the items.

b. SECTION III. Basic Issue Items. These are the minimum essential items required to place the Rotor Shop in operation, to operate it, and to perform emergency repairs. Although shipped separately packed, BII must accompany the Rotor Shop during operation and whenever it is transferred between property accounts. The illustrations will assist you with hard-to-identify items. This manual is your authority to requisition replacement BII based on the TOE/MTOE authorization of the end item.

C-3. EXPLANATION OF COLUMNS. The following provides an explanation of columns found in the tabular listings:

a. Column (1) - Illustration Number (Illus Number) This column indicates the number of the illustration in which the item is shown.

b. Column (2) - National Stock Number. Indicates the National Stock Number assigned to the item and will be used for requisitioning purposes.

c. Column (3) - Description. Indicates the Federal Item Name and, if required, a minimum description to identify and locate the item. The last line for each item indicates the CAGEC (in parentheses) followed by the part number.

d. Column (4) - Unit of Measure (U/M). Indicates the measure used in performing the actual operational/maintenance function. This measure is expressed by a two-character alphabetical abbreviation (e.g., ea, in, pr)

e. Column (5) - Quantity Required (Qty Rqr). Indicates the quantity of the item authorized to be used with/on the equipment.

SECTION II. COMPONENTS OF END ITEM

There are no components of end items associated with the Rotor Shop.

SECTION III.
BASIC ISSUE ITEMS (BII)

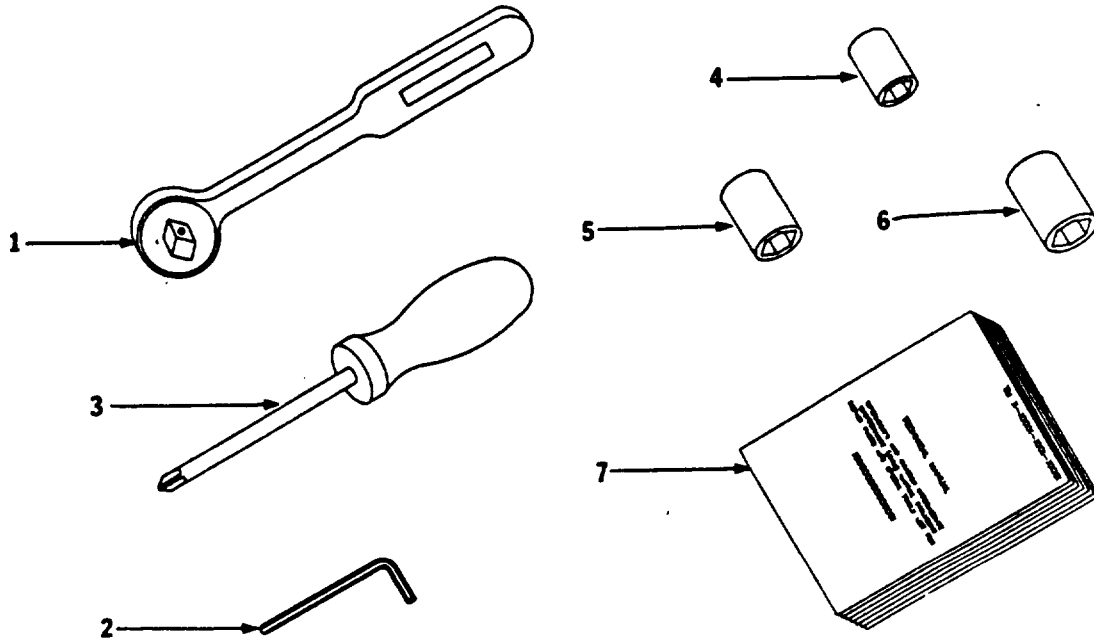

(1) Illus Number	(2) National Stock Number	(3) Description CAGEC and Part Number	(4) U/M	(5) Qty Rqr
1	5120-00-240-5364	Handle, Socket Wrench (81348)	EA	1
2	5120-00-240-5300	Key, Socket Head Screw, 3/16" (81348)	EA	1
3	5120-00-764-8097	Screwdriver, Crosstip #2 (81348)	EA	1
4	5120-00-935-7439	Socket, Socket Wrench 7/16" (81343)	EA	1
5	5120-00-935-7440	Socket, Socket Wrench 1/2" (81343)	EA	1
6	5120-00-935-7441	Socket, Socket Wrench 9/16" (81343)	EA	1
7	TM 1-4920-451-13&P	Operator's and Intermediate Maintenance Manual including Repair Parts and Special Tools List for Rotor Shop	EA	1

APPENDIX D
REPAIR PARTS AND SPECIAL TOOLS LIST

SECTION I. INTRODUCTION

D-1. SCOPE. This manual lists and authorizes spares and repair parts; special tools; special Test, Measurement, and Diagnostic Equipment (TMDE); and other special support equipment required for performance of Intermediate Maintenance of the Electrical Instrument Shop. It authorizes the requisitioning, issue, and disposition of spares, repair parts, and special tools as indicated by the Source, Maintenance, and Recoverable (SMR) codes.

D-2. General. This Repair Parts and Special Tools List is divided into the following sections:

a. Section II. Repair Parts List. A list of spares and repair parts authorized by this RPSTL for use in the performance of maintenance. The list also includes parts that must be removed for replacement of the authorized parts. Parts lists are composed of functional groups in ascending numeric sequence, with the parts in each group listed in ascending figure and item number sequence. Bulk materials are listed in NSN sequence.

b. Section III. Special Tools List. A list of special tools, special TMDE, and other special support equipment authorized by this RPSTL for the performance of maintenance.

c. Section IV. National Stock Number and Part Number Index. A list, in National Item Identification Number (NIIN) sequence, of all National Stock Numbers (NSNs) appearing in the listings, followed by a list in alphanumeric sequence of all part numbers appearing in the listing. National Stock Numbers and part numbers are cross-referenced to each illustration figure and item number appearance.

D-3. EXPLANATION OF COLUMNS.

a. Column 1, ILLUSTRATION. Column 1 is divided as follows:

(1) ((a) FIG NO.) Figure Number. Indicates the figure number illustrating an exploded view of a functional group.

(2) ((b) ITEM NO.) Indicates the number used to identify items called out in the illustration.

b. Column 2, SMR Code. The Source, Maintenance, and Recoverability (SMR) code is a 5-position code containing supply/requisitioning information, maintenance category authorization criteria, and disposition instructions, as shown in the following breakout

Source Code	Maintenance Code		Recoverability Code
x x	x	x	x
1st two positions	3rd position	4th position	5th position
How you get an item	who can install, replace or use the item.	Who can do complete repair* on the item.	Who determines disposi- tion action on an unser- viceable item.

*Complete repair: Maintenance capacity, capability, and authority to perform all corrective maintenance tasks of the "Repair" function in a use/user environment in order to restore serviceability to a failed item.

(1) Source Code. The source code tells you how to get an item needed for maintenance, repair, or overhaul of an end item/equipment. Source Codes are always the first two positions of the SMR code. Explanations of source codes follows:

Code	Explanation
PA PB PC PD PE PF PG	Stocked items; use the applicable NSN to request/requisition items with these source codes. They are authorized to the category indicated by the code entered in the 3rd position of the SMR code.

KD KF KB	Items with these codes are not to be requested/requisitioned individually. They are part of a kit which is authorized to the maintenance category indicated in the 3rd position of the SMR code. The complete kit must be requisitioned and applied.
----------------	--

Code	Explanation
MO -(Made at org / AVUM Category) MF -(Made at DS / AVM Category) MH -(Made at GS Category) MD -(Made at Depot)	Items with these codes are no to be requested/requisitioned individually. They must be made from bulk material which is identified by NSN in the Description column and listed in the Bulk Material Group in the repair parts list in this manual. If the item is authorized to you by the 3rd position of the SMR code, but the source code indicates it is made at a higher category, order the item from the higher category of maintenance.
AO -(Assembled by org / AVUM Category) AF -(Assembled by DS / AVIM Category) AH -(Assembled by GS Category) AD -(Assembled by Depot)	Items with these codes are not to be requested/requisitioned individually. The parts that make up the assembled item must be requisitioned or fabricated and assembled at the category of maintenance indicated by the source code. If the 3rd position code of the SMR code authorizes you to replace the item, but the source code indicates the item is assembled at a higher category, order the item from the higher category of maintenance.
XA	Do not requisition an "XA" - coded item. Order its next higher assembly. (Also, refer to the NOTE below.)
XB	If an "XB" item is not available from salvage, order it using the CAGEC and part number given.
XC	Installation drawing, diagram, instruction sheet, field service drawing, that is identified by manufacturer's part number.
XD	Item is not stocked. Order an "XD" - coded item through normal supply channels using the CAGEC and part number given, if no NSN is available.

NOTE

Cannibalization or controlled exchange, when authorized, may be used as a source of supply items with the above source codes, except for those source coded "XA" or those aircraft support items restricted by requirements of AR 700-42.

(2) Maintenance Code. Maintenance codes tell you the category(s) of maintenance authorized to USE and REPAIR support items. The maintenance codes are entered in the third and fourth positions of the SMR Code as follows:

(a) The maintenance code entered in the third position tells you the lowest maintenance category authorized to remove, replace, end use an item. The maintenance code entered in the third position will indicate authorization to one of the following categories of maintenance.

Code	Application/Explanation
C	Crew or operator maintenance done within organizational or aviation unit maintenance.
O	Organizational or aviation unit category can remove, replace, and use the item.
F	Direct support of aviation intermediate category can remove, replace, and use the item.
H	General support category can remove, replace, and use the item.
L	Specialized repair activity can remove, replace, and use the item.
D	Depot category can remove, replace, and use the item.

(b) The maintenance code entered in the fourth position tells you whether or not the item is to be repaired and identifies the lowest maintenance category with the capability to do complete repair (i.e., perform all authorized repair functions). (NOTE: Some limited repair may be done on the item at a lower category of maintenance, if authorized by the Maintenance Allocation Chart (MAC) and SMR codes.) This position will contain one of the following maintenance codes.

Code	Application/Explanation
O	Organizational or aviation unit is the lowest category that can do complete repair of the item.
F	Direct support or aviation intermediate is the lowest category that can do complete repair of the item.
H	General support is the lowest category that can do complete repair of the item.
L	Specialized repair activity (designate the specialized repair activity) is the lowest category that can do complete repair of the item.

Code	Application/Explanation
D	Depot is the lowest category that can do complete repair of the item.
Z	Nonreparable. No repair is authorized.
B	No repair is authorized. (No parts or special tools are authorized for the maintenance of a "B" - coded item.) However, the item may be requisitioned by adjusting, lubricating, etc., at the user level.

(3) Recoverability Code. Recoverability codes are assigned to items to indicate the disposition action on un-serviceable items. The recoverability code is entered in the fifth position of the SMR Code as follows:

Recoverability Codes	Definition
Z	Nonreparable item. When unserviceable, condemn and dispose of the item at the category of maintenance shown in 3rd position of SMR Code.
O	Reparable item. When uneconomically repairable, condemn and dispose of the item at organizational or aviation unit category.
F	Reparable item. When uneconomically repairable, condemn and dispose of the item at the direct support or aviation intermediate category.
H	Reparable item. When uneconomically repairable, condemn and dispose of the item at the general support category.
D	Reparable item. When beyond lower category repair capability, return to depot. Condemnation and disposal of item is not authorized below depot category.
L	Reparable item. Condemnation and disposal not authorized below specialized repair activity.
A	Item requires special handling or condemnation procedures because of specific reasons (i.e., precious metal content, high dollar value, critical material, or hazardous material). Refer to appropriate manuals/directives for specific instructions.

c. Column 3, NATIONAL STOCK NUMBER Column 3 lists the National stock number (NSN) assigned to the item. Use the NSN for requests/requisitions.

d. Column 4, CAGEC. Column 4, the Contractor's and Government Entity Code (CAGEC) is a 5-digit numeric code which is used to identify the manufacturer, distribute, or Government agency, etc., that supplies the item.

e. Column 5, PART NUMBER. Column 5 indicates the primary number used by the manufacturer (individual company, firm, corporation, or Government activity), which controls the design and characteristics of the item by means of its engineering drawings, specifications standards, and inspection requirements to identify an item or range of items.

NOTE

When you use an NSN to requisition an item, the item you receive may have a different part number from the part ordered, but go ahead and use or furnish it as the replacement part.

f. Column 6, DESCRIPTION. Column 6 includes the following information:

- (1) The Federal item name and, when required, a minimum description to identify the item.
- (2) The physical security classification of the item is indicated by the parenthetical entry (insert applicable physical security classification abbreviation, e.g., Phy Sec C1 (C) - Confidential, Phy Sec C1 Secret, Phy Sec C1 (T) - Top Secret).
- (3) Items included in kits and sets are listed below the name of the kit or set.
- (4) Spare/repair parts that makeup an assembled item are listed immediately following the assembled item line entry.
- (5) NSNS for bulk materials are referenced in this column in the line item entry for the item to be manufactured/fabricated.
- (6) When the item is not used with all serial numbers of the same modes, the effective serial numbers are shown on the last line(s) of the description (UOC).
- (7) The Usable On Code, when applicable.
- (8) In the Special Tools List section, the basis of issue (BOI) appears as the last line(s) in the entry for each special tool, special TMDE, and other special support equipment. When density of equipment supported exceeds density spread indicated in the basis of issue, the total authorization is increased proportionally.

g. Column 7, U/M. Column 7, Unit of Measure (U/M) indicates the measure (e.g., foot, gallon, pound) or count (e.g., each, dozen, gross) of a listed item. A two-character alpha code (e.g., FT, GL, LB, EA DZ, GR) appears in this column to indicate the measure or count. If the U/M code appearing in this column differs from the Unit of Issue (U/I) code listed in the Army Master Data File (AMDF), request the lower U/I that will satisfy your needs.

h. Column 8, QTY INC IN UNIT. Column 8, Quantity Incorporated in Unit (QTY INC IN UNIT) indicates the quantity of the item used in the breakout shown on the illustration figure, which is prepared for a functional group, subfunctional group, or an assembly. A "V" appearing in this column in lieu of a quantity indicates that no specific quantity is applicable (e.g., shims, spacers).

D-4. How to Locate Repair Parts.a. When National Stock Number or Part Number is Not Known.

- (1) First. Using the table of contents, determine the functional group or subfunctional group to which the item belongs. This is necessary since figures are prepared for functional groups and subfunctional groups, and listings are divided into the same groups.
- (2) Second. Find the figure covering the functional group or subfunctional group to which the item belongs.
- (3) Third. Identify the item on the figure and note the item number of the item.

(4) Fourth. Refer to the Repair Parts List for the figure to find the line item entry for the item number noted on the figure.

b. When National Stock Number or Part Number is Known.

(1) First. Using the Index of National Stock Numbers and Part Numbers, find the pertinent National Stock Number or Part Number. The NSN index is in National Item Identification Number (NIIN)* sequence. The part numbers in the Part Number index are listed in ascending alpha-numeric sequence both indexes cross-reference you to the illustration figure and item number of the item you are looking for.

NSN

*The NIIN consists of the last 9 digits of the NSN. (i.e., 5305-01-674-1467)

NIIN

(2) Second. finding the figure and item number, verify that the item is the one you're looking for, then locate the item number in the repair parts list for the figure.

D-7. ABBREVIATIONS. (Not applicable)

SECTION II. REPAIR PARTS LIST

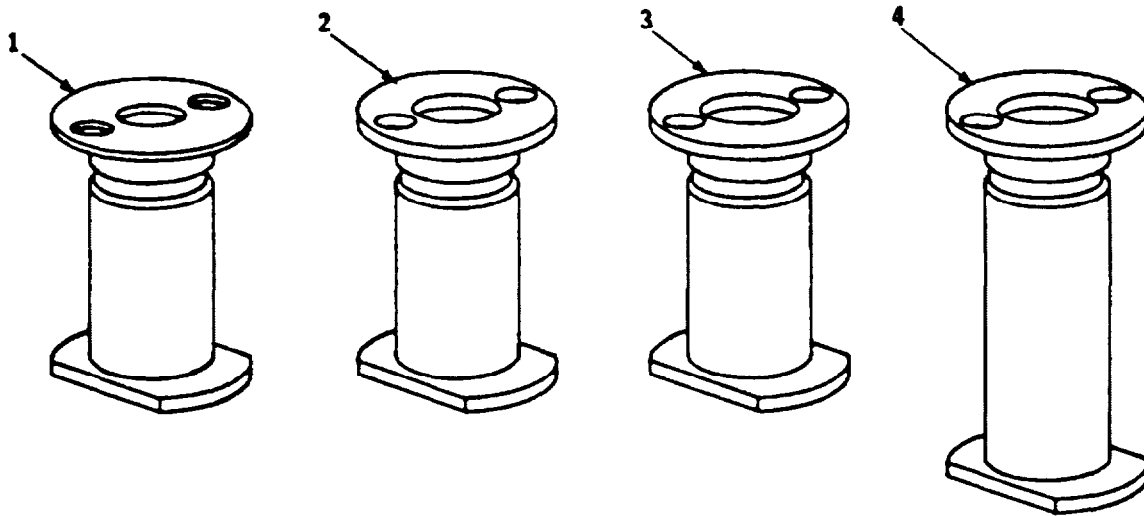

Figure D-1. Potted Inserts

(1) ILLUSTRATION		(2)	(3)	(4)	(5)	(6)	(7)	(8)
(a) FIG NO.	(b) ITEM NO.	SMR CODE	NATIONAL STOCK NUMBER	CAGEC	PART NUMBER	DESCRIPTION	U/M	QTY INC IN UNIT
D-1	1	PAFZZ		97393	SL601-4-BC	GROUP 01 FASTENERS SUBGROUP 0102 INSERTS, POTTED INSERT, FASTENER TYPE	EA	V
D-1	2	PAFZZ		97393	SL601-5-10C	INSERT, FASTENER TYPE	EA	V
D-1	3	PAFZZ		97393	SL601-6-8C	INSERT, FASTENER TYPE	EA	V
D-1	4	PAFZZ	5340-00-044-5270	97393	SL601-6-12C	INSERT, FASTENER TYPE	EA	V

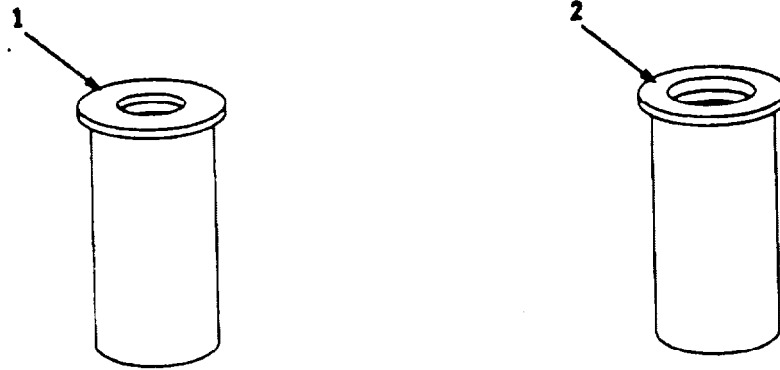

Figure D-2. Non-Potted Inserts

(1) ILLUSTRATION		(2)	(3)	(4)	(5)	(6)	(7)	(8)
(a) FIG NO.	(b) ITEM NO.	SMR CODE	NATIONAL STOCK NUMBER	CAGEC	PART NUMBER	DESCRIPTION	U/M	QTY INC IN UNIT
D-2	1	PAFZZ		73197	BN527-624-2-12	GROUP 01 FASTENERS SUBGROUP 0103 INSERTS, NON-POTTED INSERT, NON-POTTED	EA	V
D-2	2	PAFZZ		73197	BN527-624-1-12	INSERTS, NON-POTTED	EA	V

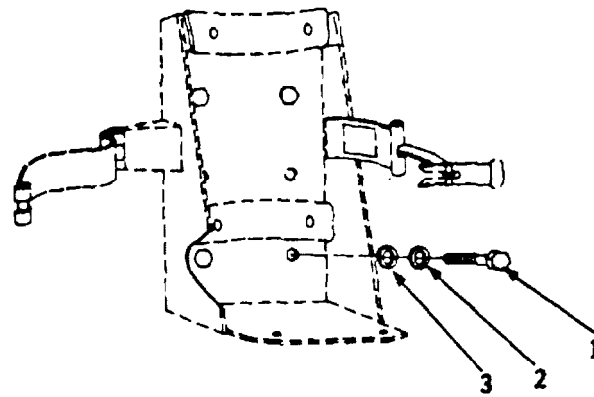

Figure D-3. Fire Extinguisher Mounting

(1) ILLUSTRATION		(2)	(3)	(4)	(5)	(6)	(7)	(8)
(A) FIG NO.	(B) ITEM NO.	SMR CODE	NATIONAL STOCK NUMBER	CAGEC	PART NUMBER	DESCRIPTION	U/M	QTY INC IN UNIT
						GROUP 02 FUTURES SUBGROUP 0201 FIRE EXTINGUISHER MOUNTNG		
D-3	1	PAFZZ	5306-00-150-9104	88044	AN5-5A	BOLT MACHINE	EA	4
D-3	2	PAFZZ	5310-00-407-9566	96906	MS35338-45	WASHER, LOCK	EA	4
D-3	3	PAFZZ	5310-00-187-2399	88044	AN960-PD-516	WASHER, FLAT	EA	4

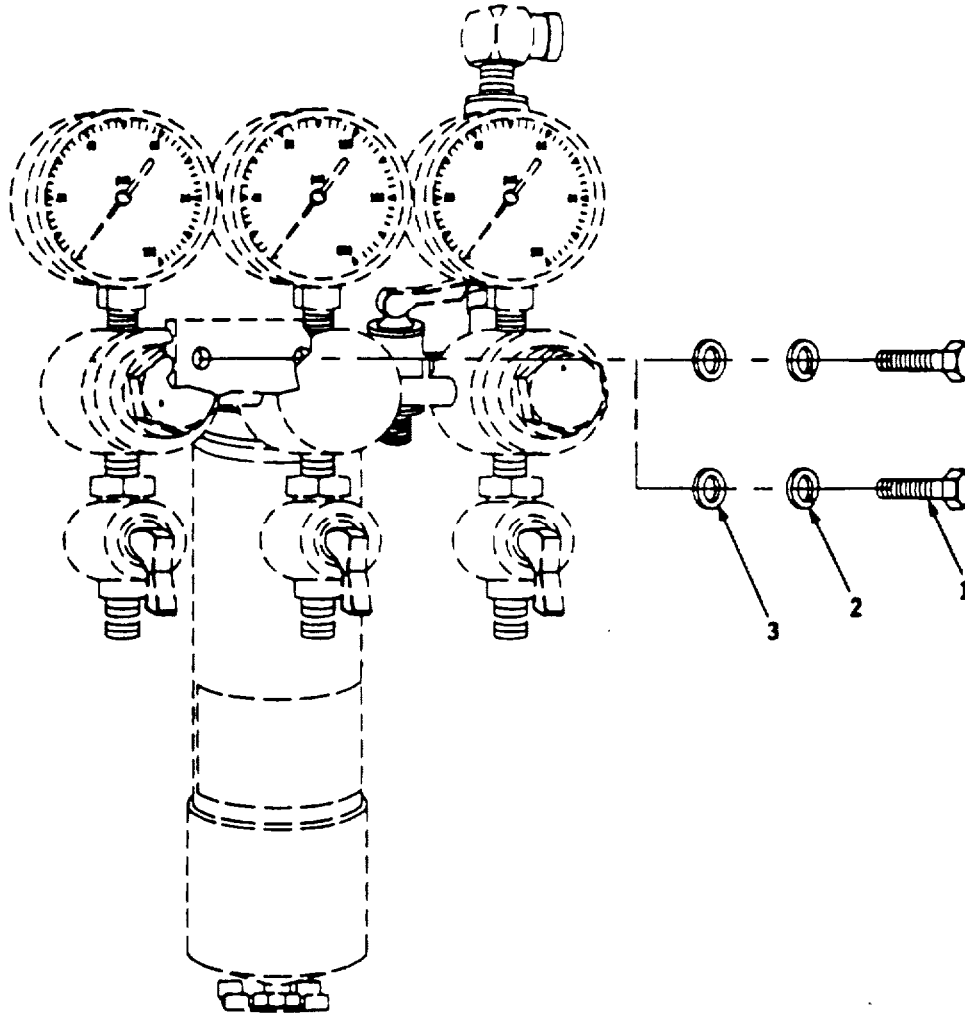

Figure D-4. Water/Oil Separator Mounting

(1) ILLUSTRATION		(2)	(3)	(4)	(5)	(6) DESCRIPTION	(7)	(8)
(a) FIG NO.	(b) ITEM NO.	SMR CODE	NATIONAL STOCK NUMBER	CAGEC	PART NUMBER		U/M	QTY INC IN UNIT
						GROUP 02 FIXTURES SUBGROUP 0202 WATER/OIL SEPARATOR MOUNTING		
D-4	1	PAFZZ	5306-00-151-1427	88044	AN4-5A	BOLT MACHINE	EA	2
D-4	2	PAFZZ	5310-00-582-5465	96906	MS3538-44	WASHER, LOCK	EA	2
D-4	3	PAFZZ	5310-00-187-2354	88044	AN960-PD-416	WASHER, FLAT	EA	2
						ALTERNATE MOUNTING		
D-5	1	PAFZZ	5306-00-150-9104	88044	AN5-5A	BOLT, MACHINE	EA	1
D-5	2	PAFZZ	5310-00-407-9566	96906	MS35338-45	WASHER, LOCK	EA	1
D-5	3	PAFZZ	5310-00-187-2399	88044	AN960-PD-516	WASHER, FLAT	EA	1

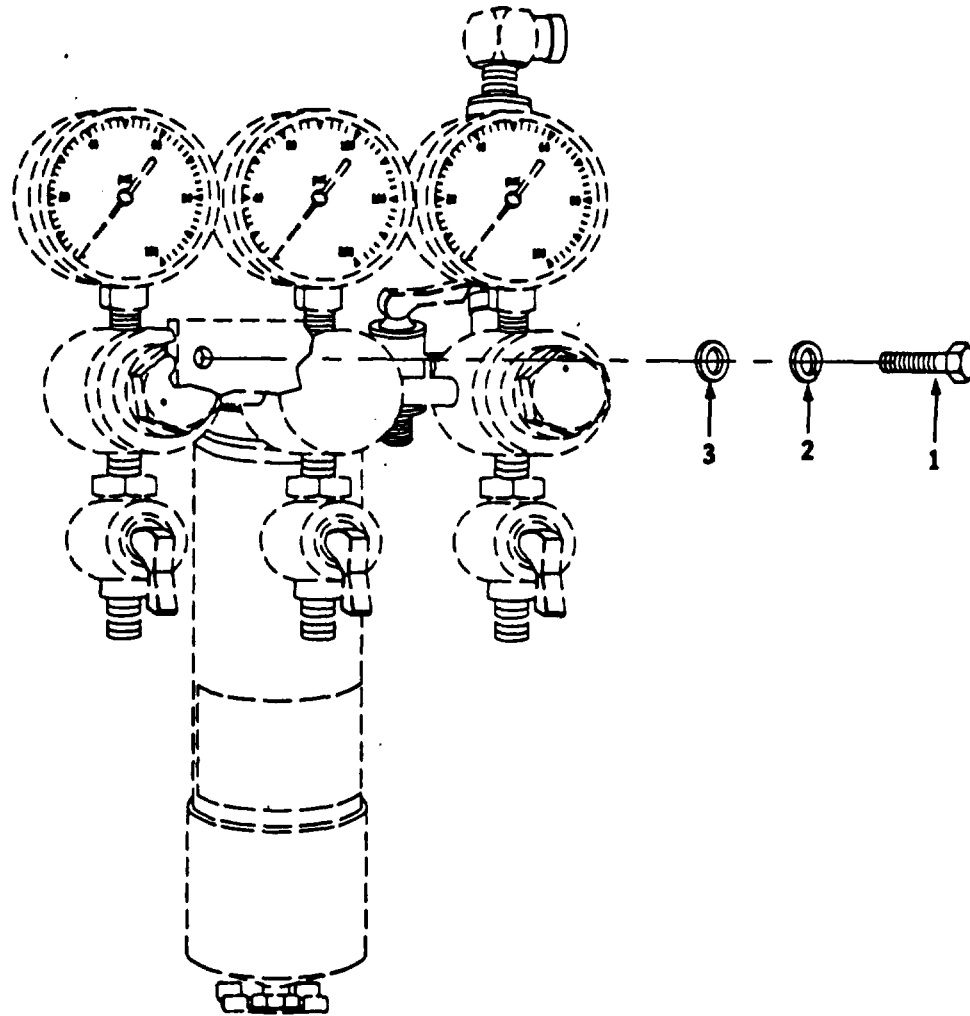

Figure D-5. Alternate Water/Oil Separator Mounting

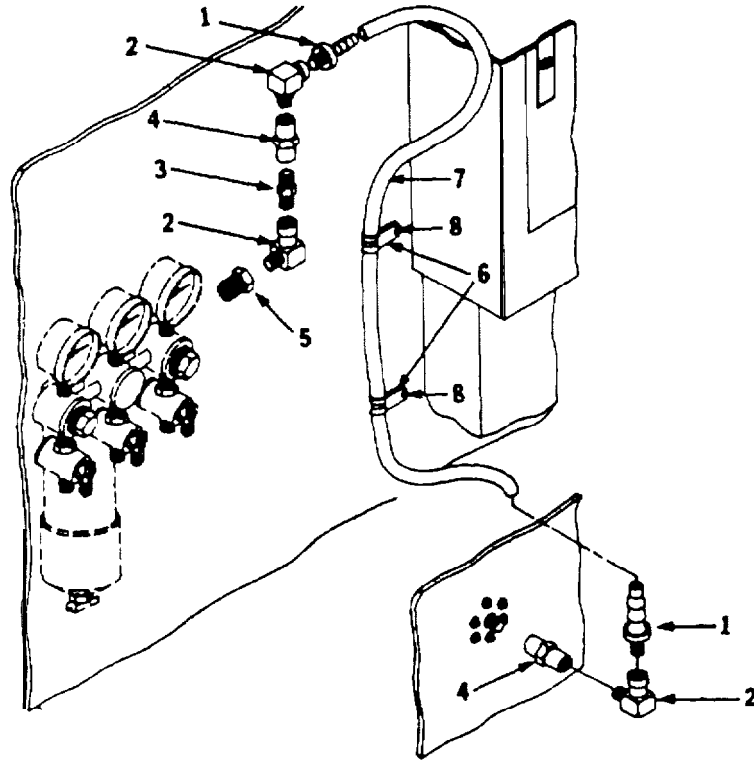

Figure D-6. Fittings and Air Hose Assy

(1) ILLUSTRATION		(2)	(3)	(4)	(5)	(6)	(7)	(8)
(a) FIG NO.	(b) ITEM NO.	SMR CODE	NATIONAL STOCK NUMBER	CAGEC	PART NUMBER	DESCRIPTION	L/M	QTY INC IN UNIT
						GROUP 02 FIXTURES SUBGROUP 0203 WATER/OIL SEPARATOR FITTINGS AND AIR HOSE ASSY		
D-6	1	PAFZZ	4730-00-932-7511	00624	4738-4-6	FITTING, HOSE	EA	2
D-6	2	PAFZZ	4730-00-595-0385	79470	C3409X4	ELBOW, PIPE	EA	3
D-6	3	PAFZZ	4730-00-287-1589	03958	896WM	NIPPLE, PIPE	EA	1
D-6	4	PAFZZ	4730-00-541-8286	88044	AN9102C	COUPLING, PIPE	EA	2
D-6	5	PAFZZ	4730-00-277-1896	96906	MS14315-5X	BUSHING, PIPE	EA	1
D-6	6	PAFZZ	5340-00-565-0004	88044	AN742-12CB	CLAMP, LOOP	EA	2
D-6	7	PAFZZ				HOSE, NON-METALLIC (SEE GROUP 99)		
D-6	8	PAFZZ	5305-00-477-0120	96906	MS51861-46C	SCREW, TAPPING THREAD	EA	2

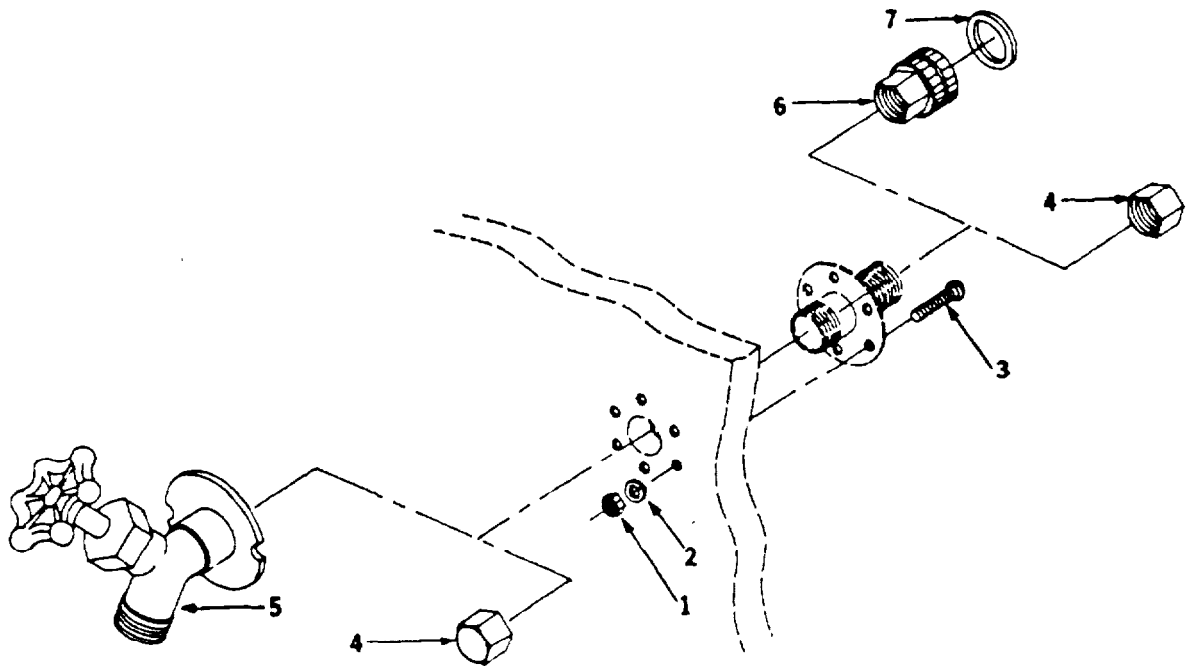

Figure D-7. Water Feed Thru Connector

(1) ILLUSTRATION		(2) SMR CODE	(3) NATIONAL STOCK NUMBER	(4) CAGEC	(5) PART NUMBER	(6) DESCRIPTION	(7) U/M	(8) QTY INC IN UNIT
(a) FIG NO.	(b) ITEM NO							
						GROUP 02 FIXTURES SUBGROUP 0204 WATER FEED THRU CONNECTOR SEE APPENDIX F. ILLUSTRATED LIST OF MANUFACTURED ITEMS FOR DETAILED DRAWING		
D-7	1	PAFZZ	5310-00-934-9751	19422	BM12297-06	NUT PLAIN, HEX	EA	6
D-7	2	PAFZZ	5310-00-167-0834	59875	TX90790-34	WASHER, FLAT	EA	6
D-7	3	PAFZZ	5310-00-082-6780	28977	AA52525-24	SCREW, MACHINE	EA	6
D-7	4	PAFZZ	4730-00-724-1998	38148	WW-P-480	CAP, PIPE	EA	2
D-7	5	PAFZZ	4510-00-142-1619	58536	A-A-232	FAUCET, SINGLE	EA	1
D-7	6	PAFZZ	4730-00-547-0941	30938	FIG1620-1	ADAPTER, STRAIGHT	EA	1
D-7	7	PAFZZ	5310-00-599-0776		NO REF	WASHER, FIAT	EA	1

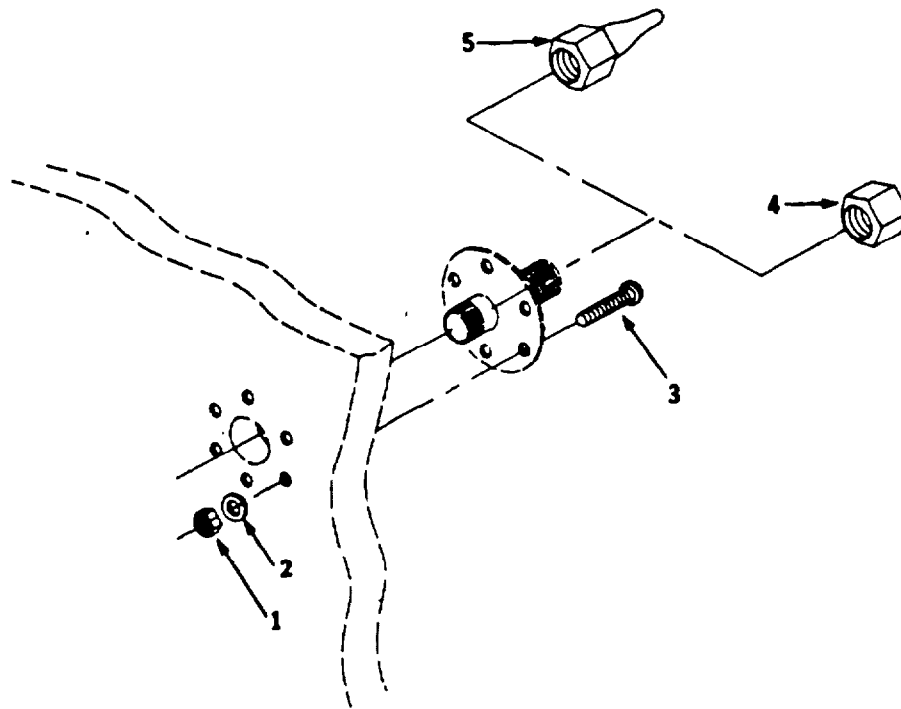

Figure D-8. Air Feed Thru Connector

(1) ILLUSTRATION		(2)	(3)	(4)	(5)	(6)	(7)	(8)
(a) FIG NO.	(b) ITEM NO.	SMR CODE	NATIONAL STOCK NUMBER	CAGEC	PART NUMBER	DESCRIPTION	U/M	QTY INC IN UNIT
						GROUP 02 FIXTURES SUBGROUP 0205 AIR FEED THRU CONNECTOR SEE APPENDIX F, ILLUSTRATED LIST OF MANUFACTURED ITEMS FOR DETAILED DRAWNG		
D-8	1	PAFZZ	5310-00-934-9751	19422	BM12297-06	NUT PLAIN, HEX	EA	6
D-8	2	PAFZZ	5310-00-167-0834	59875	TX90790-34	WASHER, FLAT	EA	6
D-8	3	PAFZZ	5310-00-082-6780	28977	AA52525-24	SCREW, MACHINE	EA	6
D-8	4	PAFZZ	4730-00-203-3169	61348	WW-P-521	CAP, PIPE	EA	2
D-8	6	PAFZZ	4730-00-142-1960	14127	SHD11	COUPLING HALF, QUICK	EA	1

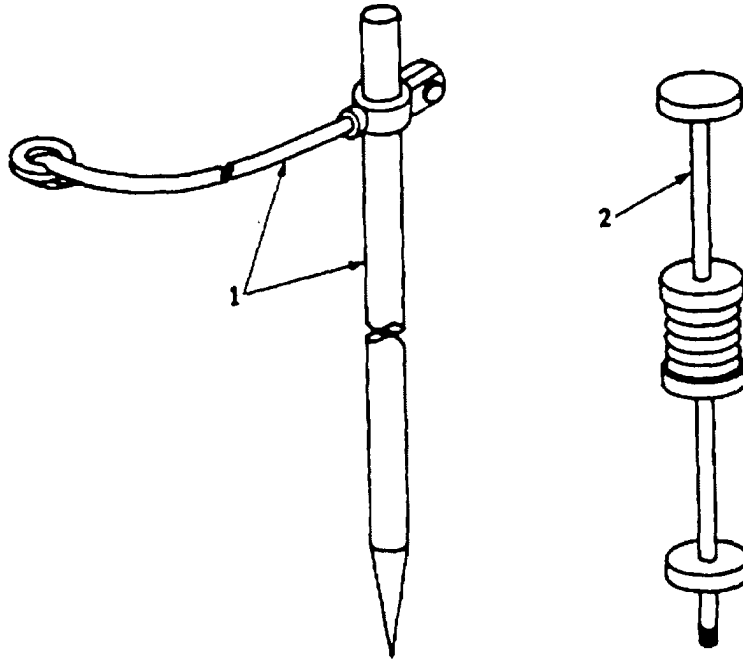

figure D-9. Ground Rod/Strap

(1) ILLUSTRATION		(2)	(3)	(4)	(5)	(6)	(7)	(8)
(a) FIG NO.	(b) ITEM NO.	SMR CODE	NATIONAL STOCK NUMBER	CAGEC	PART NUMBER	DESCRIPTION	U/M	QTY INC IN UNIT
D-9	1	PAFZZ	5975-00-878-3791	81349	MIL-R-11461	GROUP 03 ELECTRICAL SUBGROUP 0301 GROUND RODSTRAP GROUND ROD/STRAP	EA	1
D-9	2	PAFZZ	5120-01-013-1676	45225	P74-144	SLIDE HAMMER, GROUND	EA	1

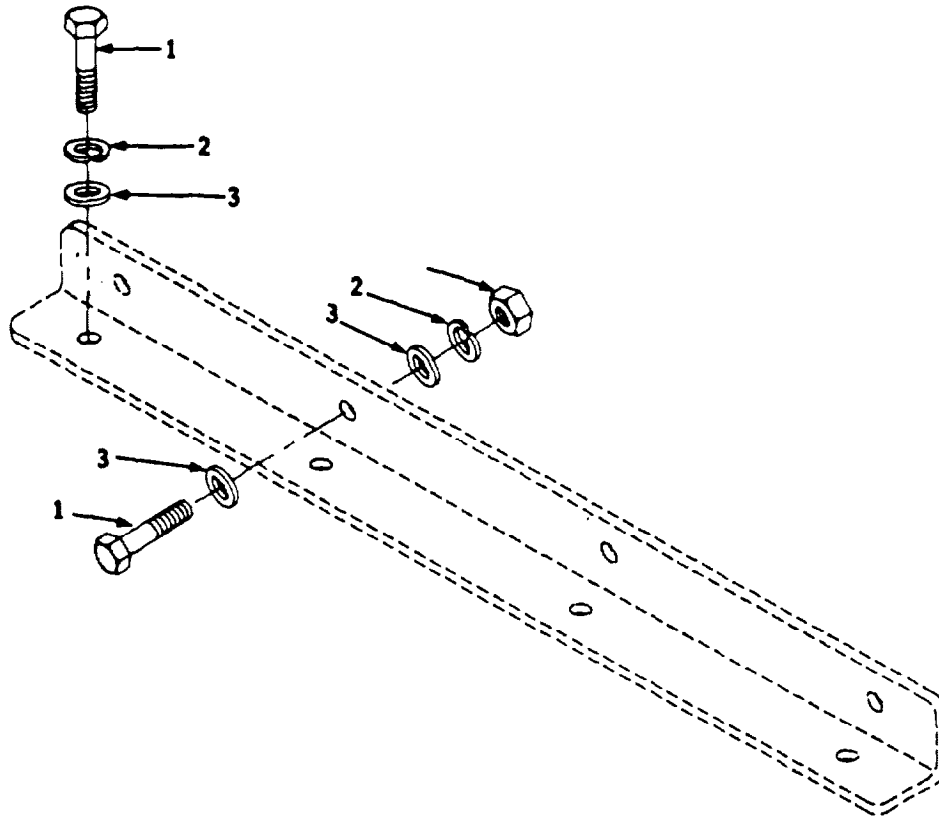

Figure D-10. Cabinet Bracket

(1) ILLUSTRATION		(2)	(3)	(4)	(5)	(6)	(7)	(8)
(a) FIG NO.	(b) ITEM NO.	SMR CODE	NATIONAL STOCK NUMBER	CAGEC	PART NUMBER	DESCRIPTION	U/M	QTY INC IN UNIT
						GROUP 4 SPECIAL BRACKETS AND FABRICATED COMPONENTS SUBGROUP 0401 BRACKETS, CABINET SEE APPENDIX F, ILLUSTRATED LIST OF MANUFACTURED ITEMS, FOR DETAILED DRAWING		
D-10	1	PAFZZ	5306-00-531-8979	88044	AN6-7A	BOLT, MACHINE	EA	8
D-10	2	PAFZZ	5310-00-637-9541	96906	MS35338-46	WASHER, LOCK	EA	8
D-10	3	PAFZZ	5310-00-187-2400	88044	AN960PD-616	WASHER, FLAT	EA	12
D-10	4	PAFZZ	5310-00-058-1626	96906	MS35650-3382	NUT	EA	4

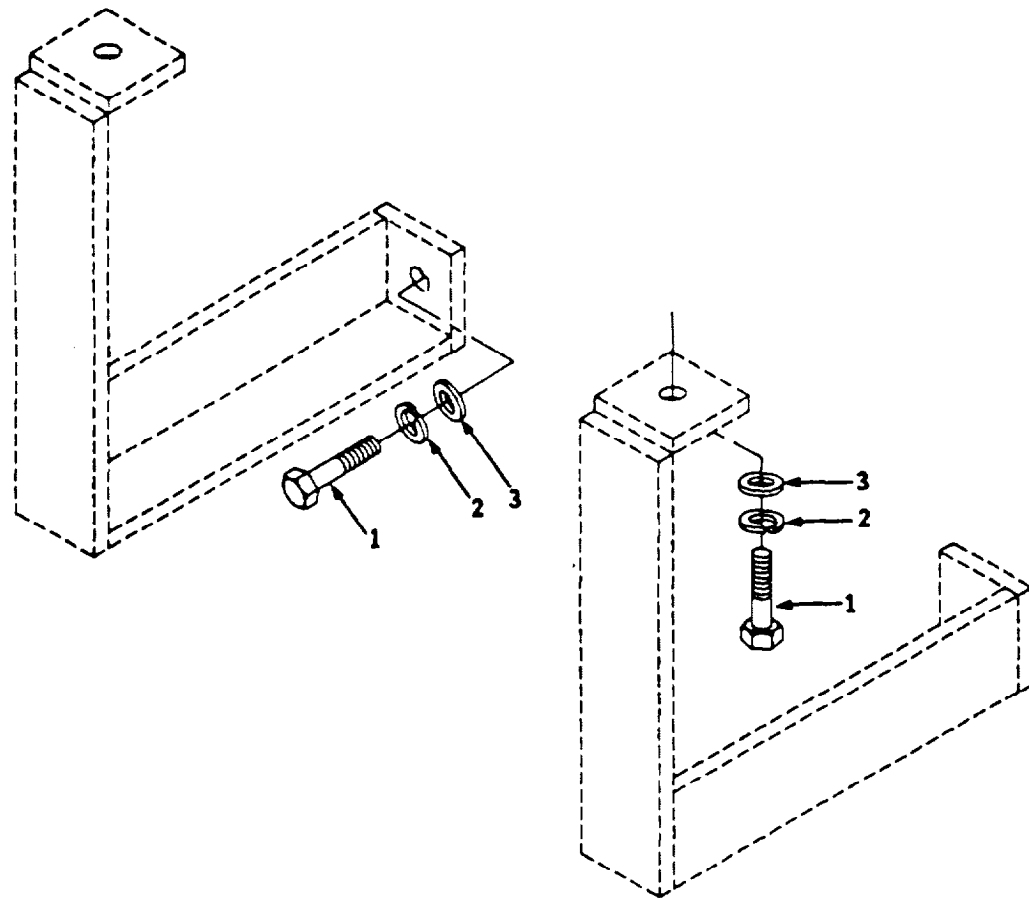
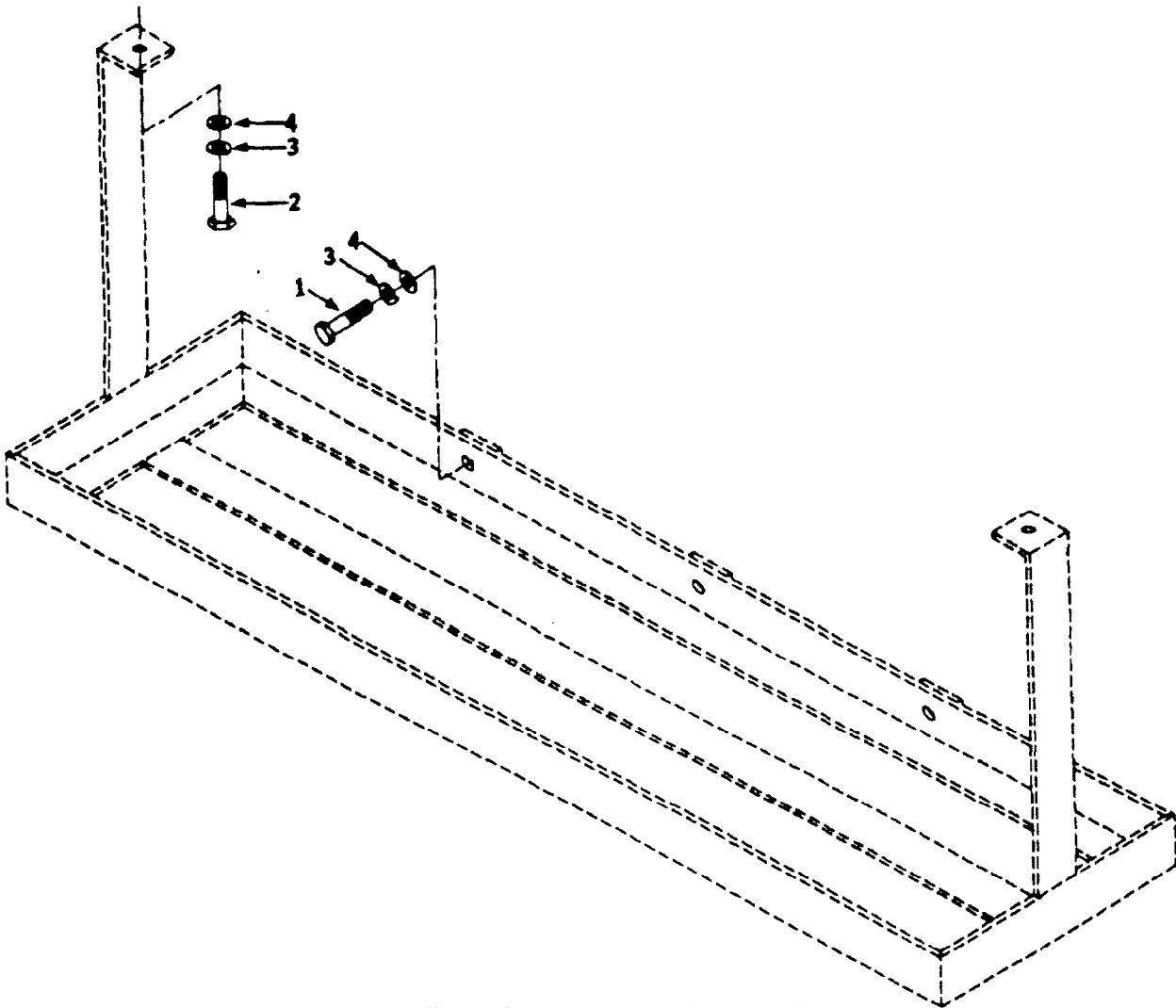

Figure D-11. Storage Chest Bracket Assemblies

(1) ILLUSTRATION		(2)	(3)	(4)	(5)	(6)	(7)	(8)
(a) FIG NO.	(b) ITEM NO	SMR CODE	NATIONAL STOCK NUMBER	CAGEC	PART NUMBER	DESCRIPTION	U/M	QTY INC IN UNIT
						GROUP 4 SPECIAL BRACKETS AND FABRICATED COMPONENTS SUBGROUP 0402 BRACKET ASSEMBLY, STORAGE CHEST,R/H AND L/H SEE APPENDIX F, ILLUSTRATED LIST OF MANUFAC- TURED ITEMS, FOR DETAILED DRAWING		
D-11	1	PAFZZ	5306-00-618-1224	88044	AN6-6A	BOLT, MACHINE	EA	4
D-11	2	PAFZZ	5310-00-637-9541	96906	MS35338-46	WASHER, LOCK	EA	4
D-11	3	PAFZZ	5310-00-187-2400	88044	AN960-PD-616	WASHER, FLAT	EA	4



(1) ILLUSTRATION		(2)	(3)	(4)	(5)	(6)	(7)	(8)
(a) FIG NO.	(b) ITEM NO.	SMR CODE	NATIONAL STOCK NUMBER	CAGEC	PART NUMBER	DESCRIPTION	U/M	QTY INC IN UNIT
						GROUP 4 SPECIAL BRACKETS AND FABRICATED COMPONENTS SUBGROUP 0403 RACK ASSEMBLY, BOOKS SEE APPENDIX F. ILLUSTRATED LIST OF MANUFACTURED ITEMS, FOR DETAILED DRAWING		
D-12	1	PAFZZ	5306-00-616-1224	88044	AN6-6A	BOLT MACHINE	EA	2
D-12	2	PAFZZ	5306-00-180-1483	88044	AN6-11A	BOLT MACHINE	EA	3
D-12	3	PAFZZ	5310-00-637-9541	96906	MS35338-46	WASHER, LOCK	EA	5
D-12	4	PAFZZ	5310-00-187-2400	88044	AN960-PD-616	WASHER, FLAT	EA	5

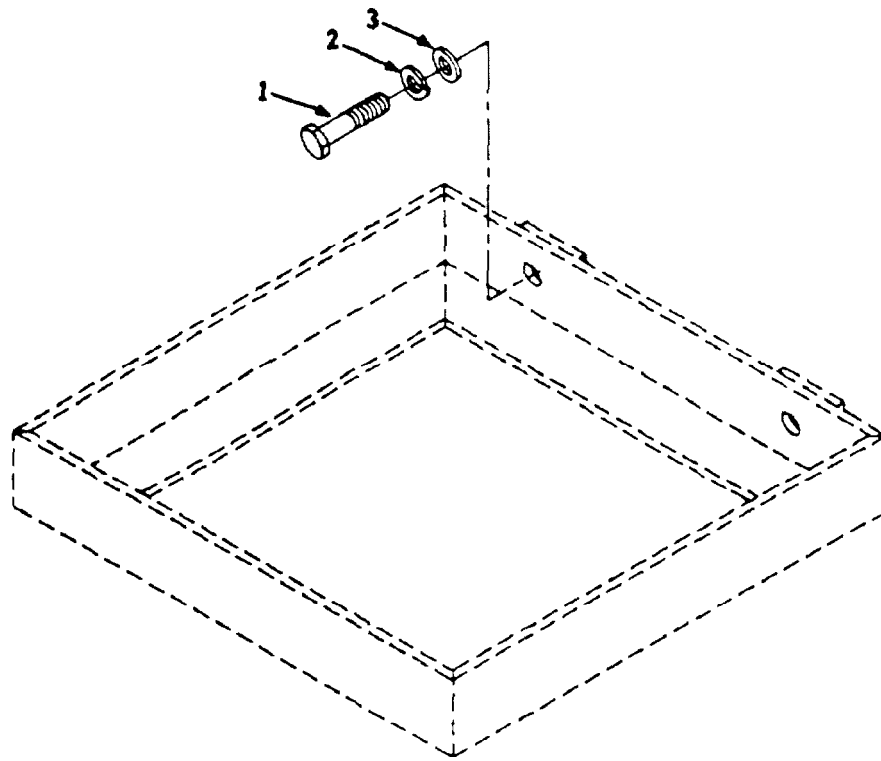

Figure D-13. First Aid Kit Rack Assembly

(1) ILLUSTRATION		(2)	(3)	(4)	(5)	(6)	(7)	(8)
(a) FIG NO.	(b) ITEM NO.	SMR CODE	NATIONAL STOCK NUMBER	CAGEC	PART NUMBER	DESCRIPTION	U/M	QTY INC IN UNIT
						GROUP 4 SPECIAL BRACKETS AND FABRICATED COMPONENTS SUBGROUP 0404 RACK ASSEMBLY, FIRST AID KIT SEE APPENDIX F. ILLUSTRATED LIST OF MANUFACTURED ITEMS, FOR DETAILED DRAWING		
D-13	1	PAFZZ	5306-00-180-1483	88044	AN6-11A	BOLT, MACHINE	EA	2
D-13	2	PAFZZ	5310-00-637-9541	96906	MS36338-46	WASHER,LOCK	EA	2
D-13	3	PAFZZ	5310-00-187-2400	88044	AN960-PD-616	WASHER,FLAT	EA	2

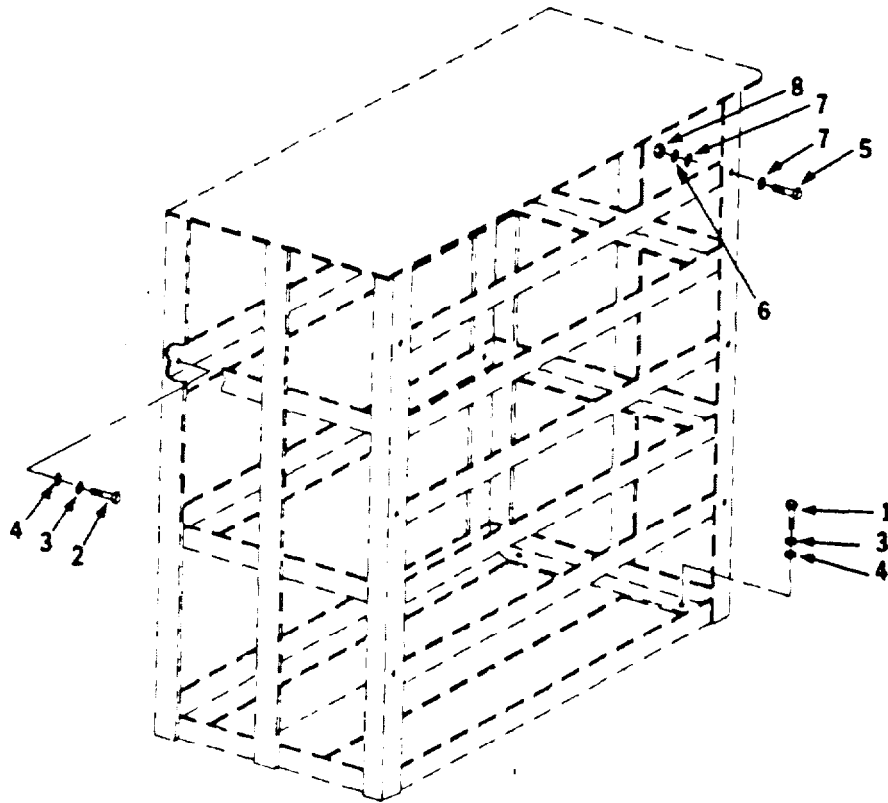

Figure D-14. Tool Box Rack Assembly

(1) ILLUSTRATION		(2)	(3)	(4)	(5)	(6)	(7)	(8)
(a) FIG NO.	(b) ITEM NO.	SMR CODE	NATIONAL STOCK NUMBER	CAGEC	PART NUMBER	DESCRIPTION	U/M	QTY INC IN UNIT
						GROUP 01 SPECIAL BRACKETS AND FABRICATED COMPONENT SUBGROUP 0405 RACK ASSEMBLY, TOOL BOX SEE APPENDIX F, ILLUSTRATED LIST OF MANUFACTURED ITEMS FOR DETAILED DRAWING		
D-14	1	PAFZZ	5306-00-616-1224	88044	AN6-6A	BOLT, MACHINE	EA	4
D-14	2	PAFZZ	5306-00-180-1483	88044	AN6-11A	BOLT, MACHINE	EA	4
D-14	3	PAFZZ	5310-00-637-9541	96906	MS35338-46	WASHER, LOCK	EA	8
D-14	4	PAFZZ	5310-00-187-2400	88044	AN960-PD-616	WASHER, FLAT	EA	8
D-14	5	PAFZZ	5306-00-145-7036	88044	AN5-10A	BOLT, MACHINE	EA	6
D-14	6	PAFZZ	5310-00-407-9566	96906	MS35338-45	WASHER, LOCK	EA	6
D-14	7	PAFZZ	5310-00-187-2399	88044	AN960-PD-516	WASHER, FLAT	EA	12
D-14	8	PAFZZ	5310-00-054-4892	96906	MS35850-3312	NUT	EA	6

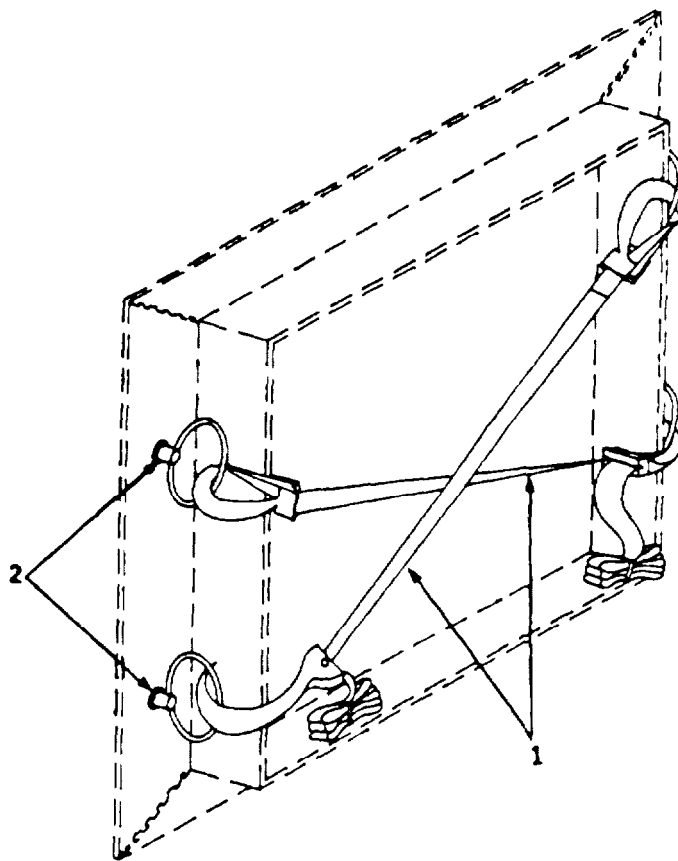

Figure D-15. ECU Support Frame Assembly

(1) ILLUSTRATION		(2)	(3)	(4)	(5)	(6)	(7)	(8)
(a) FIG NO.	(b) ITEM NO.	SMR CODE	NATIONAL STOCK NUMBER	CAGEC	PART NUMBER	DESCRIPTION	U/M	QTY INC IN UNIT
D-15	1	PAFZZ	1670-00-725-1437	81349	MIL-T-27260 TYPE CQUIB	GROUP 4 SPECIAL BRACKET'S AND FABRICATED COMPONENT SUBGROUP 0406 FRAME ASSEMBLY, ECU SUPPORT SEE APPENDIX F, ILLUSTRATED LIST OF MANUFAC- TURED ITEMS, FOR DETAILED DRAWING	EA	4
D-15	2	PAFZZ	5306-00-624-9713	98313	FDA 1658-3	TIE DOWN, CARGO BOLT, RING	EA	8

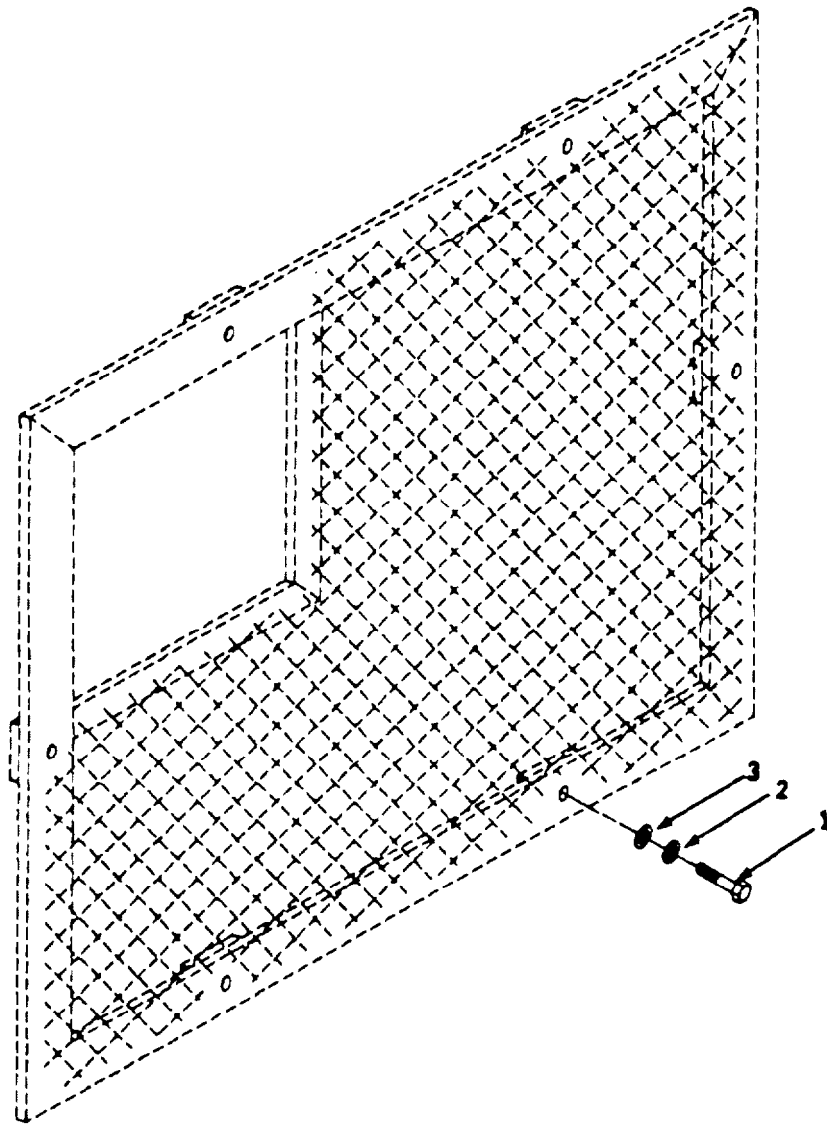

Figure D-16. ECU Security Screen

(1) ILLUSTRATION		(2)	(3)	(4)	(5)	(6)	(7)	(8)
(a) FIG NO.	(b) ITEM NO.	SMR CODE	NATIONAL STOCK NUMBER	CAGEC	PART NUMBER	DESCRIPTION	U/M	QTY INC IN UNIT
						GROUP 4 SPECIAL BRACKETS AND FASRCATED COMPONENTS SUBGROUP 0407 SECURITY SCREEN, ECU SEE APPENDIX F, ILLUSTRATED LIST OF MANUFAC- TURED ITEMS, FOR DETAILED DRAWING		
D-16	1	PAFZZ	5306-00-180-1483	88044	AN6-11A	BOLT, MACHINE	EA	6
D-16	2	PAFZZ	5310-00-637-9541	96906	MS35336-46	WASHER, LOCK	EA	6
D-16	3	PAFZZ	5310-00-187-2400	88044	AN980-PD-616	WASHER, FLAT	EA	6

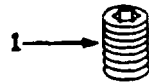

Figure D-17. Floor Plug

(1) ILLUSTRATION		(2)	(3)	(4)	(5)	(6) DESCRIPTION	(7)	(8)
(a) FIG NO.	(b) ITEM NO.	SMR CODE	NATIONAL STOCK NUMBER	CAGEC	PART NUMBER		LWM	QTY INC IN UNIT
D-17	1	PAFZZ	5306-00-728-6350	96906	M951966-90	GROUP 5 FLOOR PLUG INSERTS SCREW, SET	EA	

(1) ILLUSTRATION		(2)	(3)	(4)	(5)	(6)	(7)	(8)
(A) FIG NO.	(B) ITEM NO.	SMR CODE	NATIONAL STOCK NUMBER	CAGEC	PART NUMBER	DESCRIPTION	U/M	QTY INC IN UNIT
						GROUP 99 BULK MATERIAL		
BULK		PAFZZ	4720-00-402-9511	05415	134MKC1	HOSE	FT	V
BULK		PAFZZ		81337	MIL-M-17199C	EXPANDED ALUMINUM SHEET	SH	V
BULK		PAFZZ	9530-00-228-9315	81348	QQ-A-200/8	METAL BAR	FT	V
BULK		PAFZZ	9530-00-237-0721	81348	QQ-A-200/8	METAL BAR	FT	V
BULK		PAFZZ	9530-00-228-9316	81348	QQ-A-200/8	METAL BAR	FT	V
BULK		PAFZZ	9535-00-231-8230	81348	QQ-A-250/11	METAL SHEET	SH	V
BULK		PAFZZ	9515-00-141-8066	81346	ASTM A366	SHEET STEEL	SH	V
BULK		PAFZZ	9540-00-197-9850	01634	QQ-A-200/8	STRUCTURAL ANGLE	FT	V

SECTION III. SPECIAL TOOLS LIST (NOT APPLICABLE)

SECTION IV. NATIONAL STOCK NUMBER AND PART NUMBER INDEX

NATIONAL STOCK NUMBER INDEX

STOCK NUMBER	FIGURE NO	ITEM NO	STOCK NUMBER	FIGURE NO	ITEM NO
5120-01-013-1676	D-09	2	9535-00-231-8230	BULK	
5340-00-044-5270	D-01	4	9530-00-237-0721	BULK	
5310-00-054-4892	D-14	8	4730-00-277-1896	D-06	5
5310-00-058-1626	D-10	4	4730-00-287-1589	D-06	3
5310-00-082-6780	D-07	3	4720-00-402-9511	BULK	
5310-00-082-6780	D-08	3	5310-00-407-9566	D-03	2
9515-00-141-8066	BULK		5310-00-407-9566	D-05	2
4510-00-142-1619	D-07	5	5310-00-407-9566	D-14	6
4730-00-142-1960	D-08	5	5305-00-477-0120	D-06	8
5306-00-145-7036	D-14	5	5306-00-531-8979	D-10	1
5306-00-150-9104	D-03	1	4730-00-541-8286	D-06	4
5306-00-150-9104	D-05	1	4730-00-547-0941	D-07	6
5306-00-151-1427	D-04	1	5340-00-565-0004	D-06	6
5310-00-167-0834	D-07	2	5310-00-582-5965	D-04	2
5310-00-167-0834	D-08	2	4730-00-595-0385	D-06	2
5310-00-180-1483	D-12	2	5310-00-599-0776	D-07	7
5306-00-180-1483	D-13	1	5306-00-616-1224	D-11	1
5306-00-180-1483	D-14	2	5306-00-616-1224	D-12	1
5306-00-180-1483	D-16	1	5306-00-616-1224	D-14	1
5310-00-187-2354	D-04	3	5306-00-624-9713	D-15	2
5310-00-187-2399	D-03	3	5310-00-637-9541	D-10	2
5310-00-187-2399	D-05	3	5310-00-637-9541	D-11	2
5310-00-187-2399	D-14	7	5310-00-637-9541	D-12	3
5310-00-187-2400	D-10	3	5310-00-637-9541	D-13	2
5310-00-187-2400	D-11	3	5310-00-637-9541	D-14	3
5310-00-187-2400	D-12	4	5310-00-637-9541	D-16	2
5310-00-187-2400	D-13	3	4730-00-724-1998	D-07	4
5310-00-187-2400	D-14	4	1670-00-725-1437	D-15	1
5310-00-187-2400	D-16	3	5305-00-728-6350	D-17	1
9540-00-197-9850	BULK		5975-00-878-3791	D-09	1
4730-00-203-3168	D-08	4	4730-00-932-7511	D-06	1
9530-00-228-9315	BULK		5310-00-934-9751	D-07	1
9530-00-228-9316	BULK		5310-00-934-9751	D-08	1

PART NUMBER INDEX

CAGEC	PART NO	FIG NO	ITEM NO	CAGEC	PART NO	FIG NO	ITEM NO
58536	A-A-232	D-07	5	81349	MIL-T-27260		
28977	AA52525-24	D-07	3		TYPECGU1B	D-15	1
28977	AA52525-24	D-08	3	81337	MIL-M-17199C	BULK	
88044	AN4-5A	D-04	1	81349	MIL-R-11461	D-09	1
88044	AN5-10A	D-14	5	96906	MS14315-5X	D-06	5
88044	AN5-5A	D-03	1	96906	MS35338-44	D-04	2
88044	AN5-5A	D-05	1	96906	MS35338-45	D-03	2
88044	AN6-6A	D-11	1	96906	MS35338-45	D-05	2
88044	AN6-6A	D-12	1	96906	MS35338-45	D-14	6
88044	AN6-6A	D-14	1	96906	MS35338-46	D-12	3
88044	AN6-7A	D-10	1	96906	MS35338-46	D-10	2
88044	AN6-11A	D-12	2	96906	MS35338-46	D-11	2
88044	AN6-11A	D-13	1	96906	MS35338-46	D-13	2
88044	AN6-11A	D-14	2	96906	MS35338-46	D-14	3
88044	AN6-11A	D-16	1	96906	MS35338-46	D-16	2
88044	AN742-12CB	D-06	6	96906	MS35650-3312	D-14	8
88044	AN9102C	D-06	4	96906	MS35650-3382	D-10	4
88044	AN960-PD-416	D-04	3	96906	MS51861-46C	D-06	8
88044	AN960-PD-516	D-03	3	96906	MS51966-90	D-17	1
88044	AN960-PD-516	D-05	3	45225	P74-144	D-09	2
88044	AN960-PD-516	D-14	7	81348	QQ-A-200/8	BULK	
88044	AN960-PD-616	D-10	3	01634	QQ-A-200/8	BULK	
88044	AN960-PD-616	D-11	3	81348	QQ-A-250/11	BULK	
88044	AN960-PD-616	D-12	4	14127	SHD11	D-08	5
88044	AN960-PD-616	D-13	3	97393	SL601-4-8C	D-01	1
88044	AN960-PD-616	D-14	4	97393	SL601-5-10C	D-01	2
88044	AN960-PD-616	D-16	3	97393	SL601-6-8C	D-01	3
81346	ASTM A366	BULK		97393	SL601-6-12C	D-01	4
19422	BM12297-06	D-08	1	59875	TX90790-34	D-07	2
19422	BM12297-06	D-07	1	59875	TX90790-34	D-08	2
73197	BN527-624-2-12	D-02	1	81348	WW-P-460	D-07	4
73197	BN527-524-1-12	D-02	2	81348	WW-P-521	D-08	4
79470	C3409X4	D-06	2	05415	134MKC1	BULK	
98313	FDA 1658-3	D-15	2	00624	4738-4-6	D-06	1
30938	FIG 1620-1	D-07	6	03958	896WM	D-06	3

**APPENDIX E
EXPENDABLE/DURABLE SUPPLIES AND MATERIALS LIST**

E-1. Scope This appendix lists expendable/durable supplies and materials you will need to operate and maintain the Rotor Shop. This listing is for informational purposes only and is not authority to requisition the listed items. These items are authorized to you by CTA 50-970, Expendable Items (Except Medical, Class V, Repair Parts and Heraldic Items), or CTA 8-100, Army Medical Department Expendable/Durable Items.

E-2. Explanation of Columns

a. Column 1 - Item Number. This number is assigned to the enjoy in the listing and is referenced in the narrative instructions to identify the material (e.g., "Use corrosion prevention components (item 1, app. E)").

b. Column 2- Level. This column identifies the lowest level of maintenance that requires the listed item.

AVIM - Aviation Intermediate Maintenance

c. Column 3- National Stock Number. This is the National stock number assigned to the item; use it to request or requisition the item.

d. Column 4 - Description. Indicates Federal item name and, if required, a description to identify the item. The last line for each item indicates the Contractor and Government Entity Code (CAGEC) in parentheses followed by the part number.

e. Column 5 - Unit of Measure (U/M). Indicates the measure used in performing the actual maintenance function. This measure is expressed by a two-character alphabetical abbreviation (e.g., ea, in, pr). If the unit of measure differs from the unit of issue, requisition the lowest unit of issue that will satisfy your requirements.

(1) ITEM NO.	(2) LEVEL	(3) NATIONAL STOCK NUMBER	(4) DESCRIPTION, PART NO. AND CAGEC	(5) U/M
1	AVIM	8040-00-270-8137	ADHESIVE, (81348) MMM-A-134	TU
2	AVIM	8040-00-877-9872	ADHESIVE, (81349) MIL-A-46106	TU
3	AVIM	8015-00-271-1511	BAG, COTTON, MAILING (81348) PPP-B-20	BD
4	AVIM	8010-00-852-9034	ENAMEL, GRAY (81348) 16187	PT
5	AVIM	8010-00-159-4520	ENAMEL, WHITE (81348) 17773	PT
6	AVIM	8010-00-297-0593	PRIMER, COATING (81348) TT-P-1757	PT
7	AVIM	3439-00-063-5200	ROD, WELDING (81348) 5356	LB

APPENDIX F
ILLUSTRATED LIST OF MANUFACTURED ITEMS

F-1. Scope. This appendix includes simplified line drawing illustrations for each item authorized to be manufactured/fabricated, modified or mounted by aviation intermediate maintenance personnel.

F-2. Introduction.

a. This appendix includes complete instructions for making items authorized to be manufactured or fabricated at aviation intermediate maintenance.

b. A part number index in alphanumeric order is provided for cross-referencing the part number of the item to be manufactured to the figure which covers fabrication criteria.

c. All bulk materials needed for manufacture of an item are listed by part number or specification number in a tabular list on the illustration.

d. All dimensions are given in U.S. Standard measures.

F-3. Manufactured Items part number Index.

PART NUMBER	NOMENCLATURE	FIG NO.
20083250	WATER FEED THRU CONNECTOR	1
20087058	AIR FEED THRU CONNECTOR	2
20089718	BRACKET, CABINET	3
20089712	BRACKET ASSEMBLY, STORAGE CHEST, R/H	4
20089713	BRACKET ASSEMBLY, STORAGE CHEST, L/H	5
20089710	RACK ASSEMBLY, BOOK	6
20089721	RACK ASSEMBLY, FIRST AID KIT	7
20089720	RACK ASSEMBLY, TOOL BOX	8
20089711	FRAME ASSEMBLY, ECU	9
20089727	SECURITY SCREEN, ECU	10

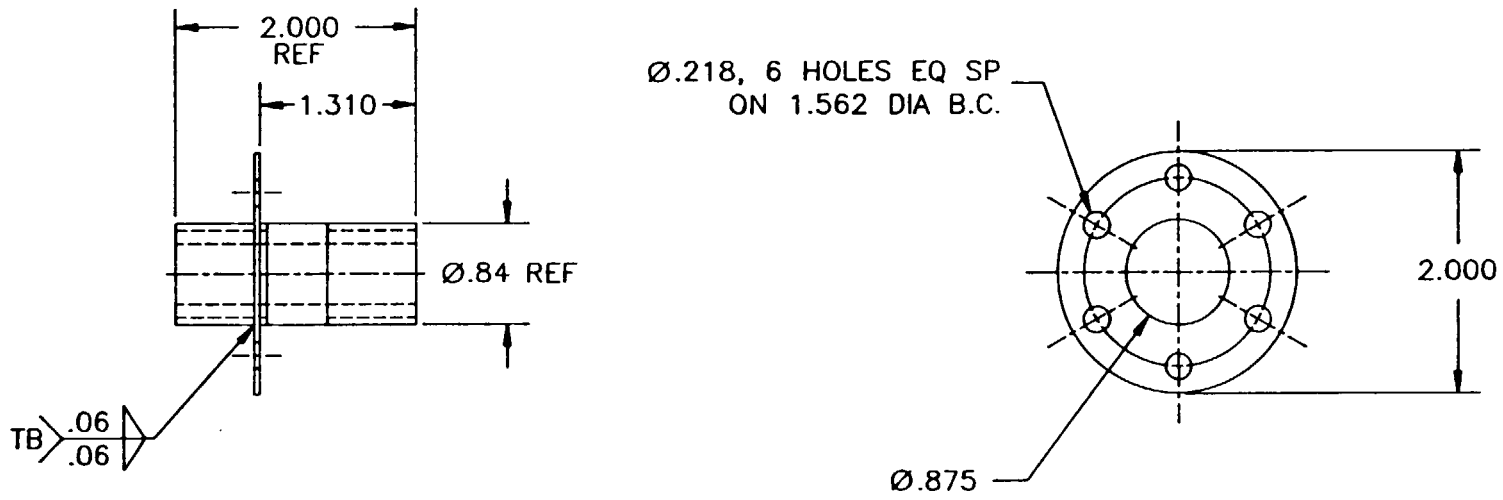

- NOTES:**
1. FABRICATE FROM:
 - A. SHEET STEEL, 18 GAUGE,
NSN 9515-00-141-8066,
 - B. NIPPLE PIPE, .500 X 2.00,
NSN 4730-00-196-1493.
 2. ALL DIMENSIONS ARE IN INCHES.

Figure 1. Water Feed Thru Connector Part Number 20083250.

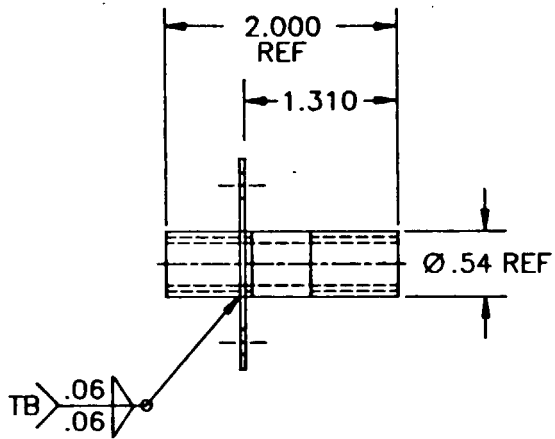

Ø.218, 6 HOLES EQ SP
ON 1.375 DIA B.C.

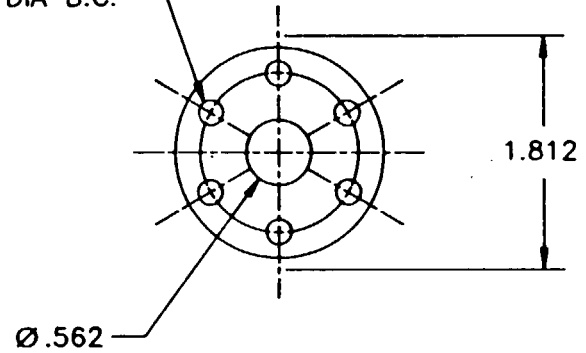

NOTES:

1. FABRICATE FROM:
 - A. SHEET STEEL, 18 GAUGE,
NSN 9515-00-141-8066,
 - B. NIPPLE PIPE, .500 X 2.00,
NSN 4730-00-196-1493.
2. ALL DIMENSIONS ARE IN INCHES.

Figure 2. Air Feed Thru Connector Part Number 20087058.

NOTES:

1. FABRICATE FROM:
STRUCTURAL ANGLE, 6061-T6
ALUMINUM ALLOY 2.00 X 2.00 X 0.25,
NSN 9540-00-197-9850.
2. TWO REQUIRED.
3. WELD WITH 5356 ROD OR EQUAL.
4. ALL DIMENSIONS ARE IN INCHES.
5. FINISH: PRIMER, TT-P-1757
6. FINISH: GRAY, PN 16187

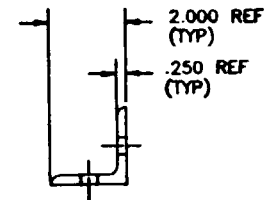
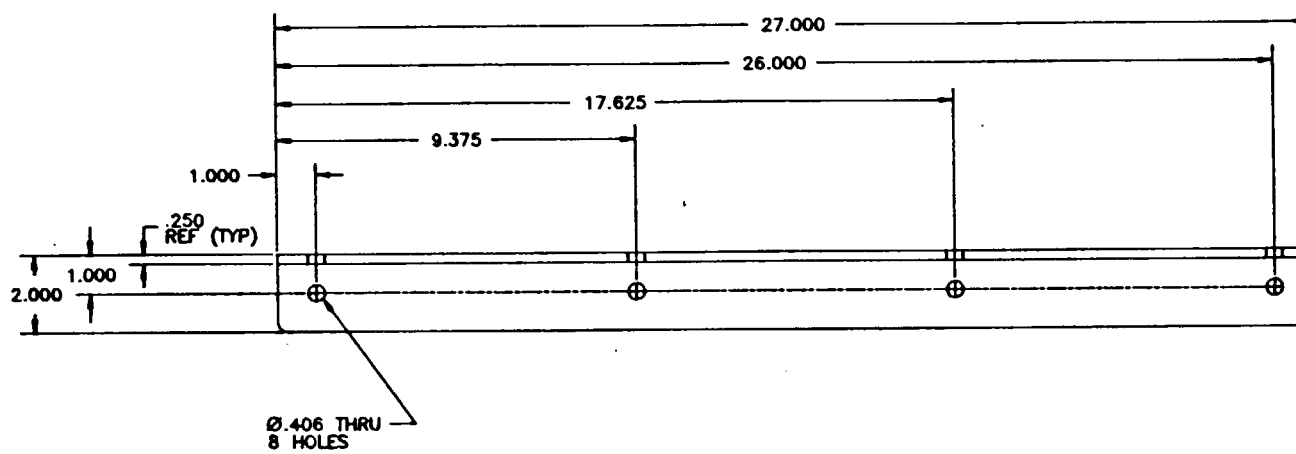

SIDE VIEW

Figure 3. Cabinet Bracket Part Number 20089718.

NOTES:

1. FABRICATE FROM:
 - A. STRUCTURAL ANGLE, 6061-T6
ALUMINUM ALLOY 2.00 X 2.00 X 0.25,
NSN 9540-00-197-9850.
 - B. METAL BAR, 6061-T6
ALUMINUM ALLOY, 2.00 X 0.25,
NSN 9530-00-228-9315.
2. WELD WITH 5356 ROD OR EQUAL.
3. ALL DIMENSIONS ARE IN INCHES.
4. FINISH: PRIMER, TT-P-1757
5. FINISH: WHITE, PN 17773

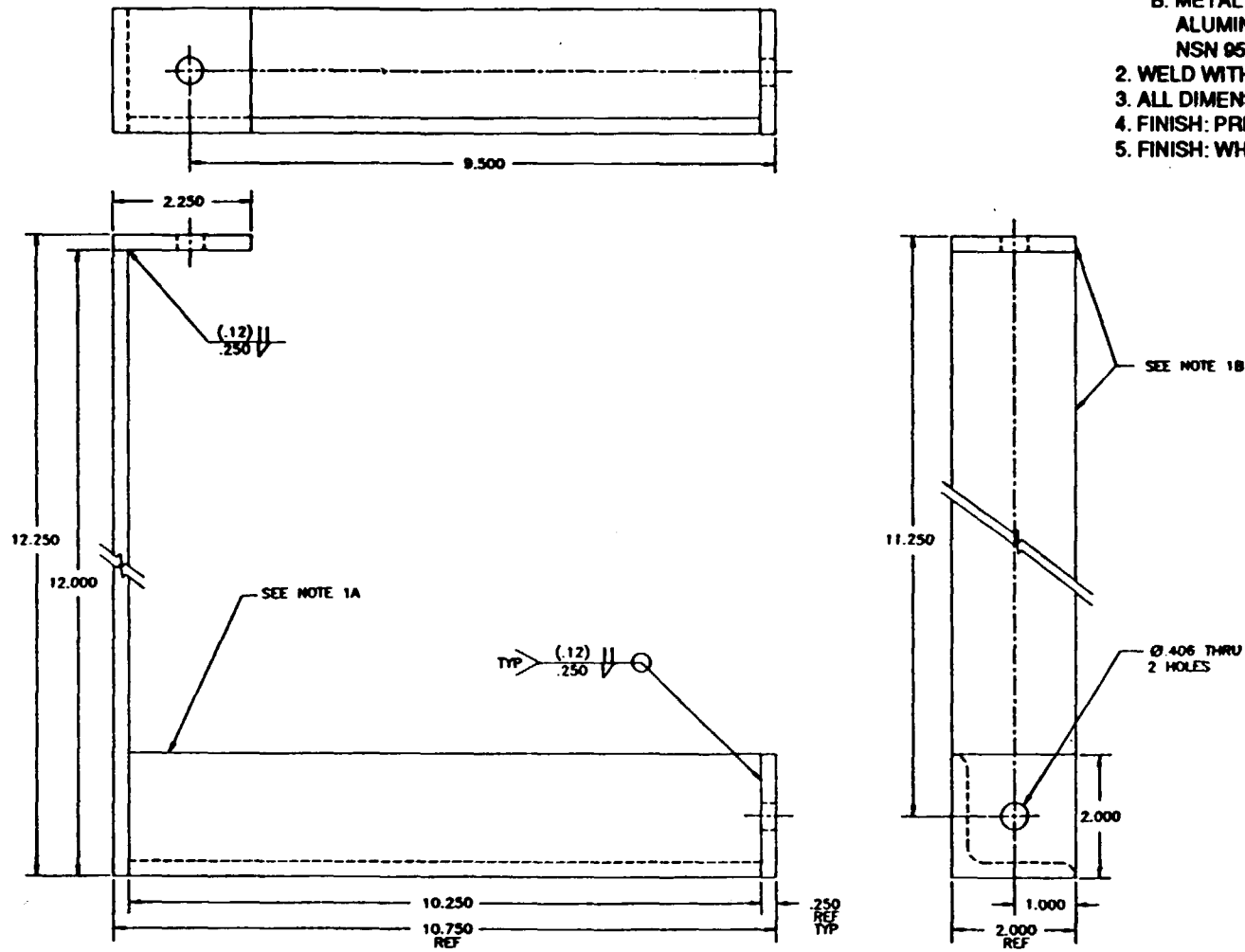
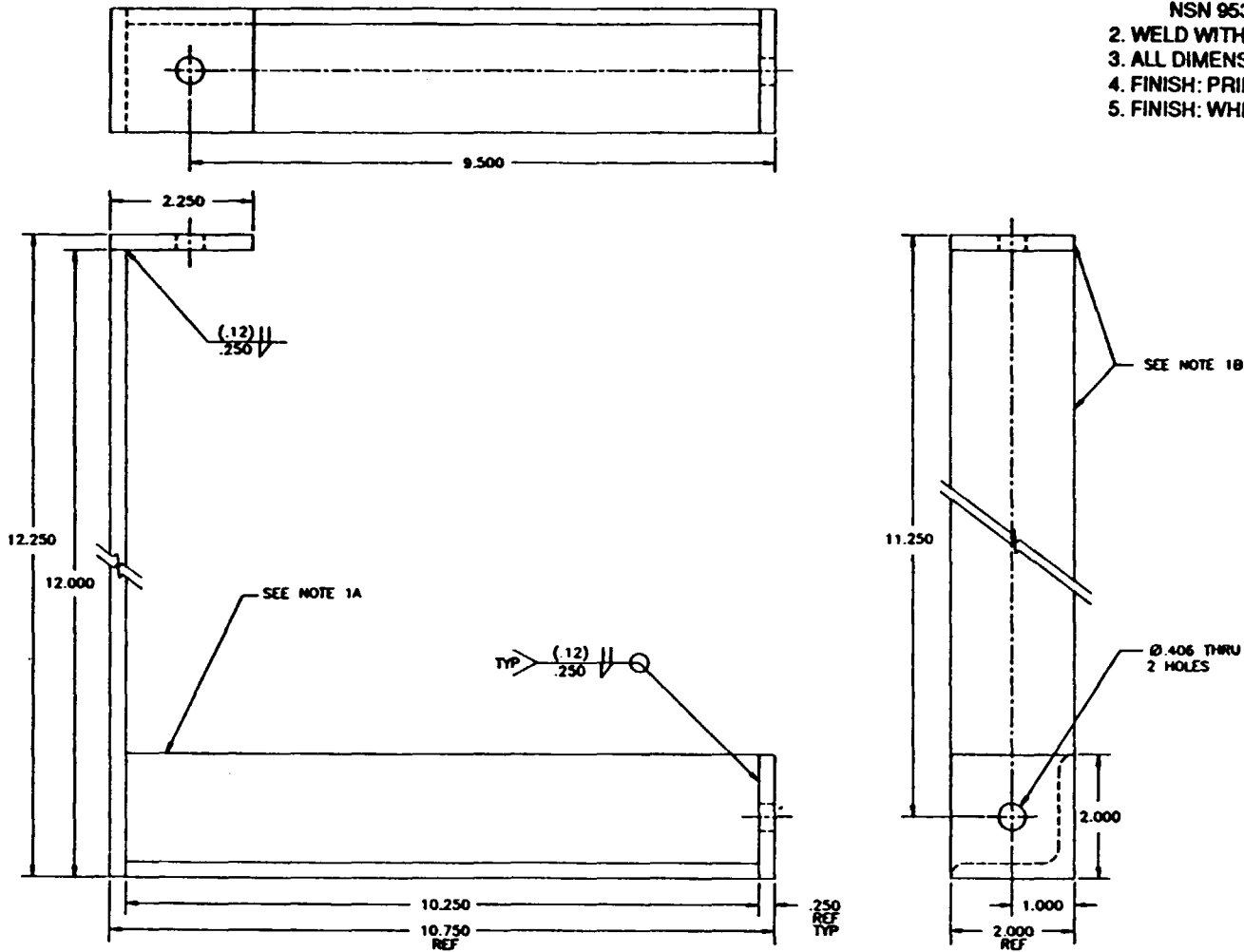

Figure 4. Storage Chest Bracket Assembly (R/H) Part Number 20089712.



NOTES:

1. FABRICATE FROM:
 - A. STRUCTURAL ANGLE, 6061-T6 ALUMINUM ALLOY 2.00 X 2.00 X 0.25, NSN 9540-00-197-9850.
 - B. METAL BAR, 6061-T6 ALUMINUM ALLOY, 2.00 X 0.25, NSN 9530-00-228-9315.
2. WELD WITH 5356 ROD OR EQUAL.
3. ALL DIMENSIONS ARE IN INCHES.
4. FINISH: PRIMER, TT-P-1757
5. FINISH: WHITE, PN 17773

Figure 5. Storage Chest Bracket Assembly (L/H) Part Number 20089713.

NOTES:

1. FABRICATE FROM:
 - A. STRUCTURAL ANGLE, 6061-T6
ALUMINUM ALLOY 2.00 X 2.00 X 0.25,
NSN 9540-00-197-9850.
 - B. METAL BAR, 6061-T6
ALUMINUM ALLOY, 2.00 X 0.25,
NSN 9530-00-228-9315.
2. WELD WITH 5356 ROD OR EQUAL.
3. ALL DIMENSIONS ARE IN INCHES.
4. FINISH: PRIMER, TT-P-1757
5. FINISH: WHITE, PN 17773

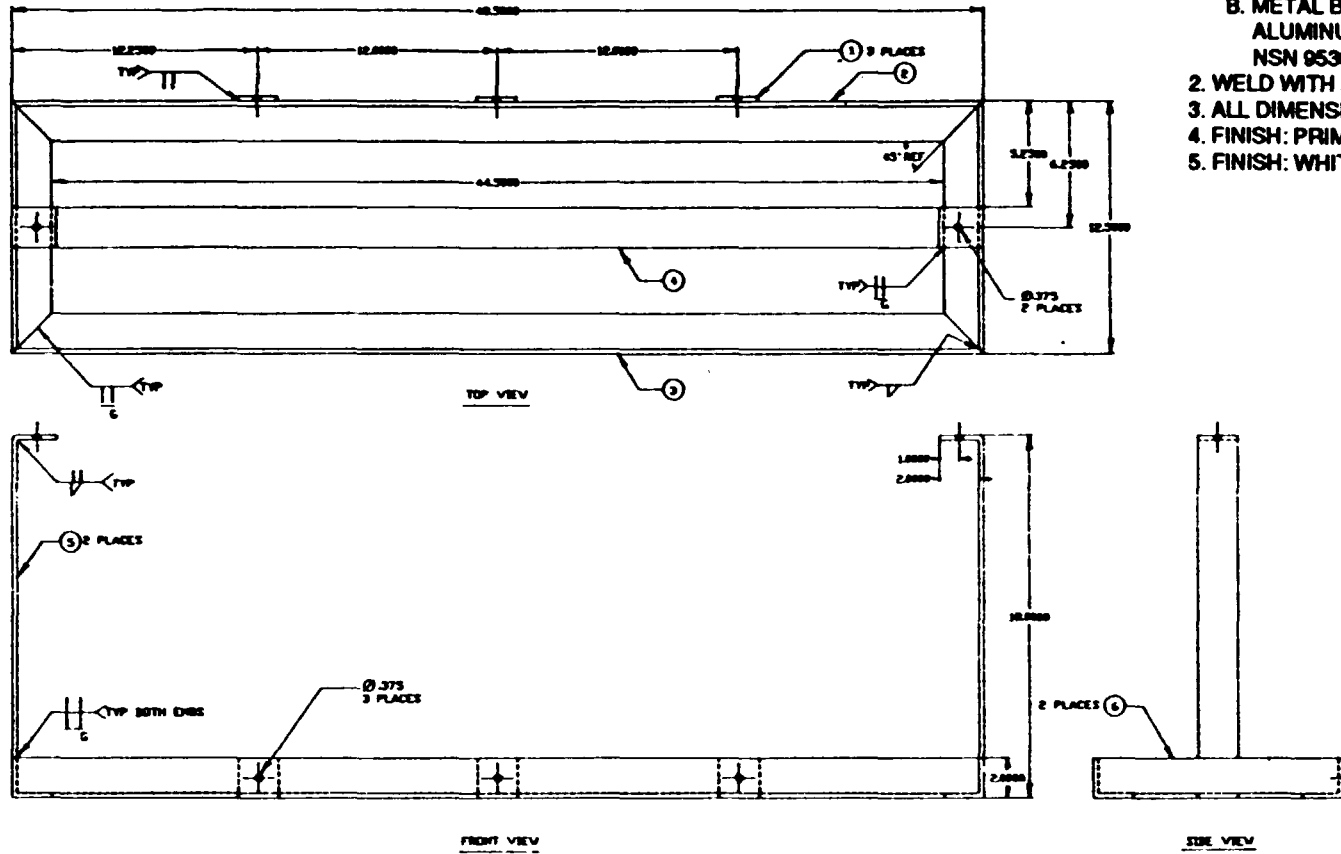
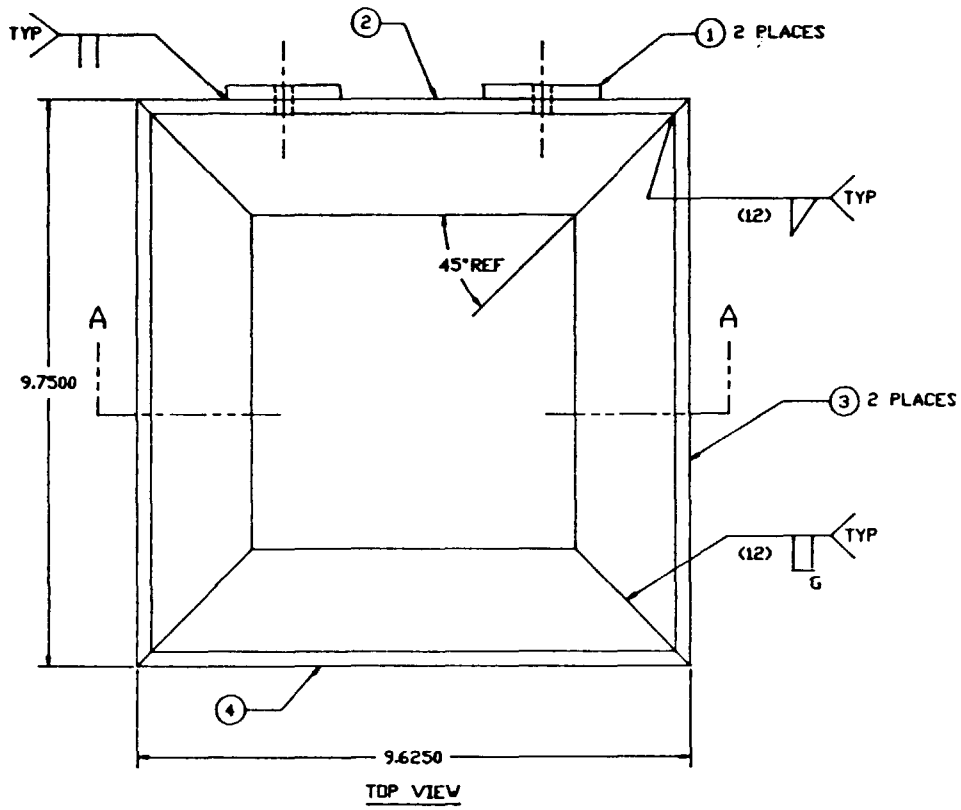
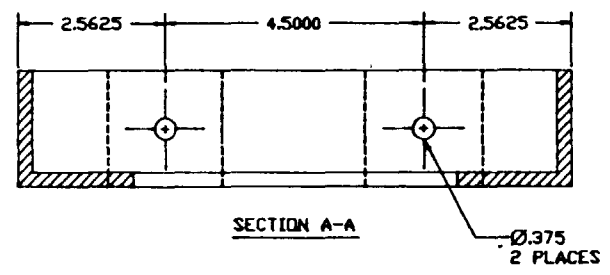

Figure 6. Book Rack Assembly Part Number 20089710.



TOP VIEW



SECTION A-A

Ø.375
2 PLACES

NOTES:

1. FABRICATE FROM:
 - A. STRUCTURAL ANGLE, 6061-T6 ALUMINUM ALLOY 2.00 X 2.00 X 0.25, NSN 9540-00-197-9850.
 - B. METAL BAR, 6061-T6 ALUMINUM ALLOY, 2.00 X 0.25, NSN 9530-00-228-9315.
2. WELD WITH 5356 ROD OR EQUAL.
3. ALL DIMENSIONS ARE IN INCHES.
4. FINISH: PRIMER, TT-P-1757
5. FINISH: WHITE, PN 17773

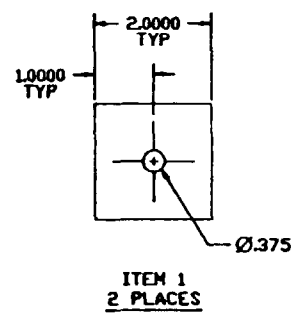

ITEM 1
2 PLACES

Figure 7. First Aid Kit Rack Assembly Part Number 20089721.

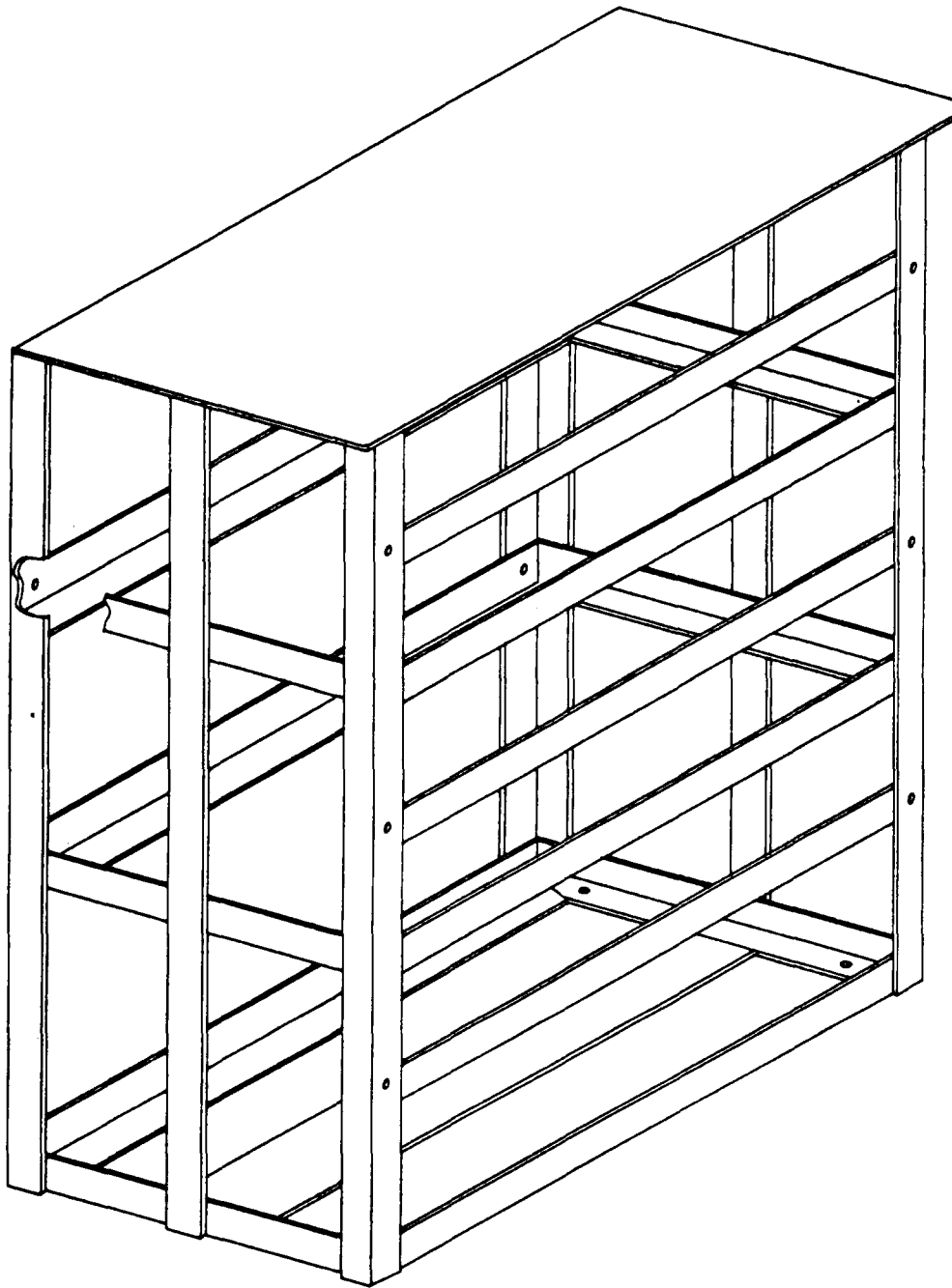

Figure 8. Tool Box Rack Assembly Pad Number 20089720-1 (Sheet 1 of 11).

NOTES:

1. FABRICATE FROM:
METAL PLATE, 6061-T6
ALUMINUM ALLOY
NSN 9535-00-231-8230
2. WELD WITH 5356 ROD OR EQUAL.
3. ALL DIMENSIONS ARE IN INCHES.
4. FINISH: PRIMER, TT-P-1757
5. FINISH: WHITE, PN 17773

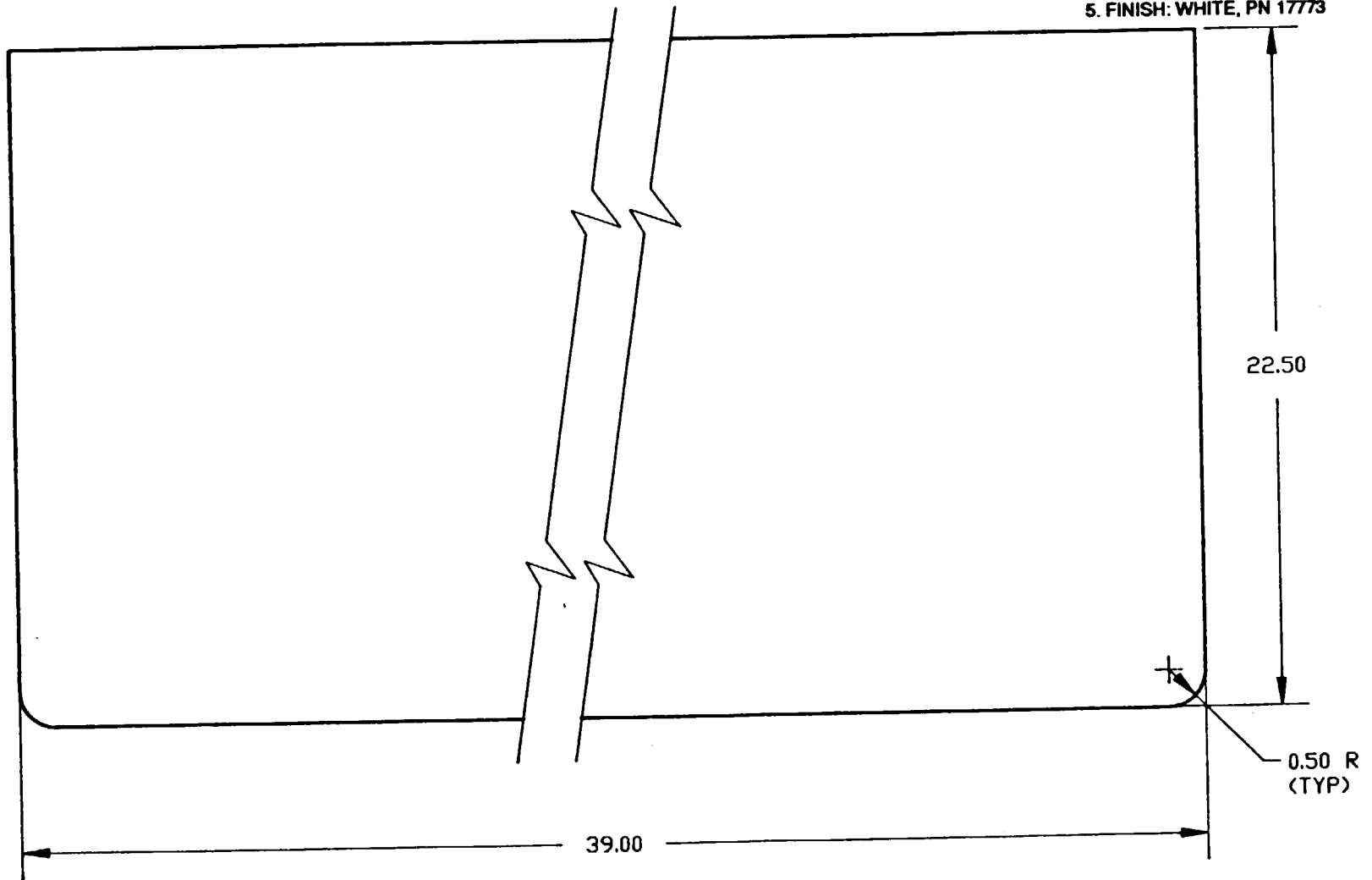

Figure 8. Tool Box Rack Assembly Part Number 20089720-2 (Sheet 2 of 11).

NOTES:

1. FABRICATE FROM:
STRUCTURAL ANGLE, 6061-T6
ALUMINUM ALLOY 2.00 X 2.00 X 0.25,
NSN 9540-00-197-9850.
2. TWO REQUIRED.
3. WELD WITH 5356 ROD OR EQUAL.
4. ALL DIMENSIONS ARE IN INCHES.
5. FINISH: PRIMER, TT-P-1757
6. FINISH: WHITE, PN 17773

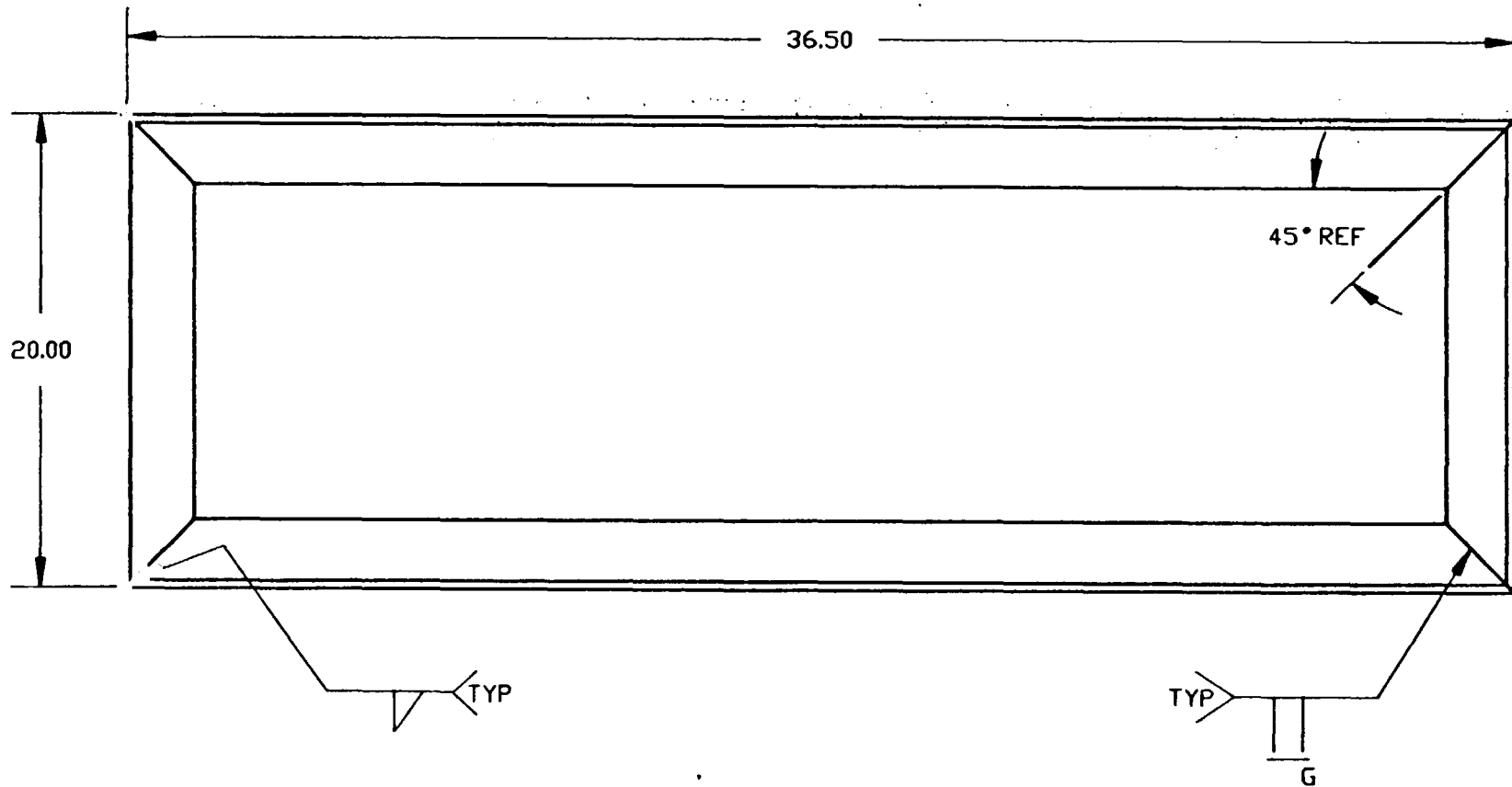

Figure 8. Tool Box Rack Assembly Part Number 20089720-3 (Sheet 3 of 11).

NOTES:

1. FABRICATE FROM:
STRUCTURAL ANGLE, 6061-T6
ALUMINUM ALLOY 2.00 X 2.00 X 0.25,
NSN 9540-00-197-9850.
2. WELD WITH 5356 ROD OR EQUAL.
3. ALL DIMENSIONS ARE IN INCHES.
4. FINISH: PRIMER, TT-P-1757
5. FINISH: WHITE, PN 17773

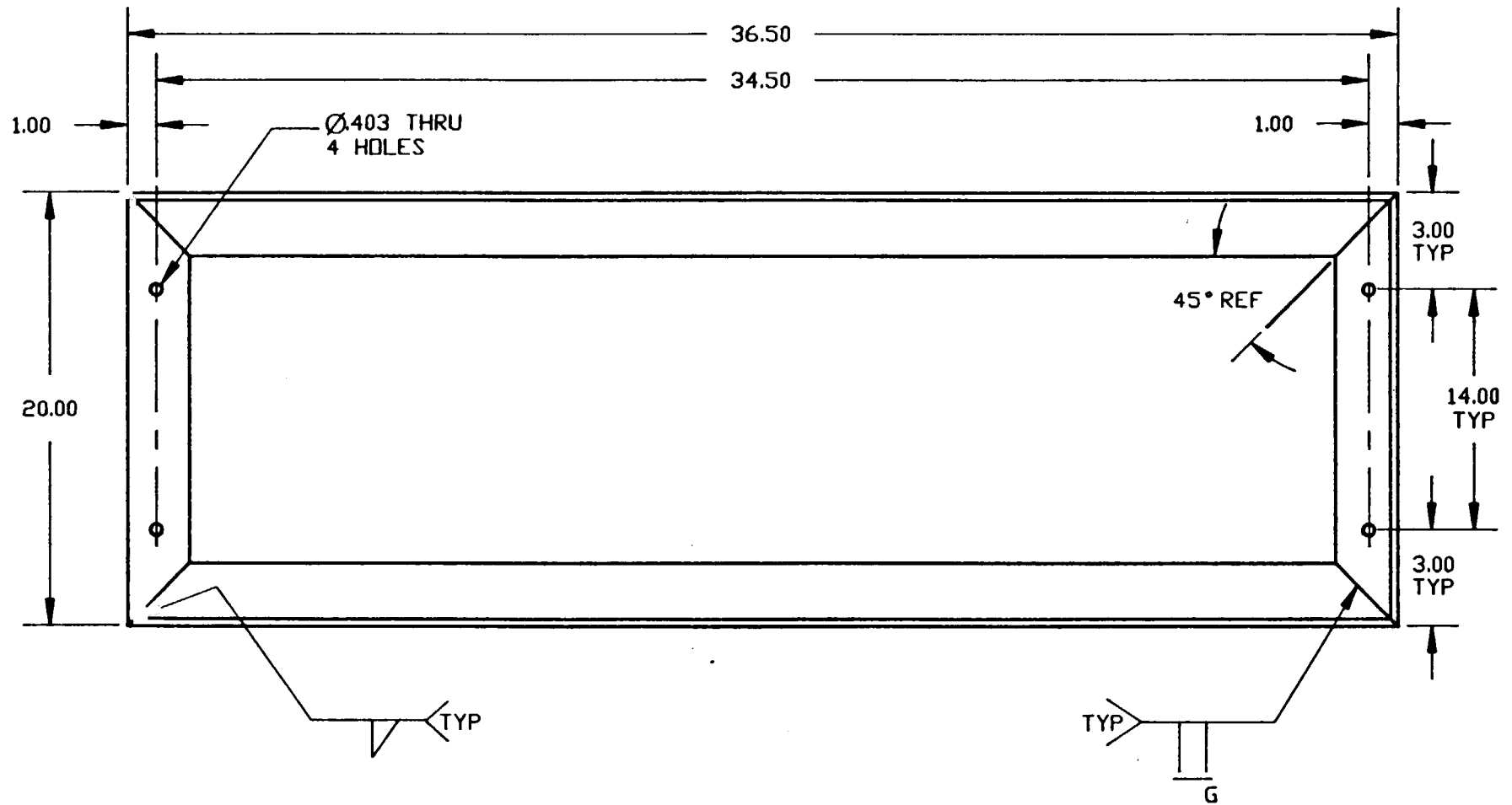

Figure 8. Tool Box Rack Assembly Part Number 20089720-4 (Sheet 4 of 11).

NOTES:

1. FABRICATE FROM:
STRUCTURAL ANGLE, 6061-T6
ALUMINUM ALLOY 2.00 X 2.00 X 0.25,
NSN 9540-00-197-9850.
2. WELD WITH 5356 ROD OR EQUAL.
3. ALL DIMENSIONS ARE IN INCHES.
4. FINISH: PRIMER, TT-P-1757
5. FINISH: WHITE, PN 17773

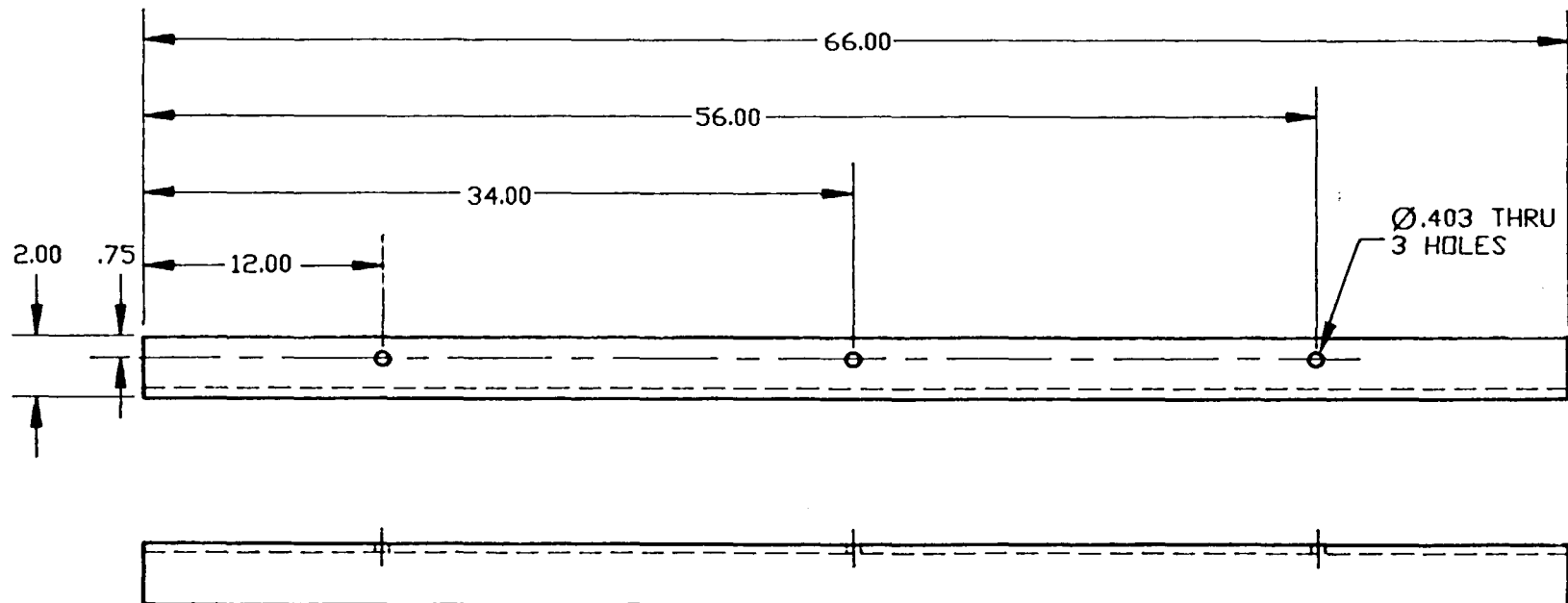

Figure 8. Tool Box Rack Assembly Part Number 20089720-5 (Sheet 5 of 11).

NOTES:

1. FABRICATE FROM:
STRUCTURAL ANGLE, 6061-T6
ALUMINUM ALLOY 2.00 X 2.00 X 0.25,
NSN 9540-00-197-9850.
2. WELD WITH 5356 ROD OR EQUAL.
3. ALL DIMENSIONS ARE IN INCHES.
4. FINISH: PRIMER, TT-P-1757
5. FINISH: WHITE, PN 17773

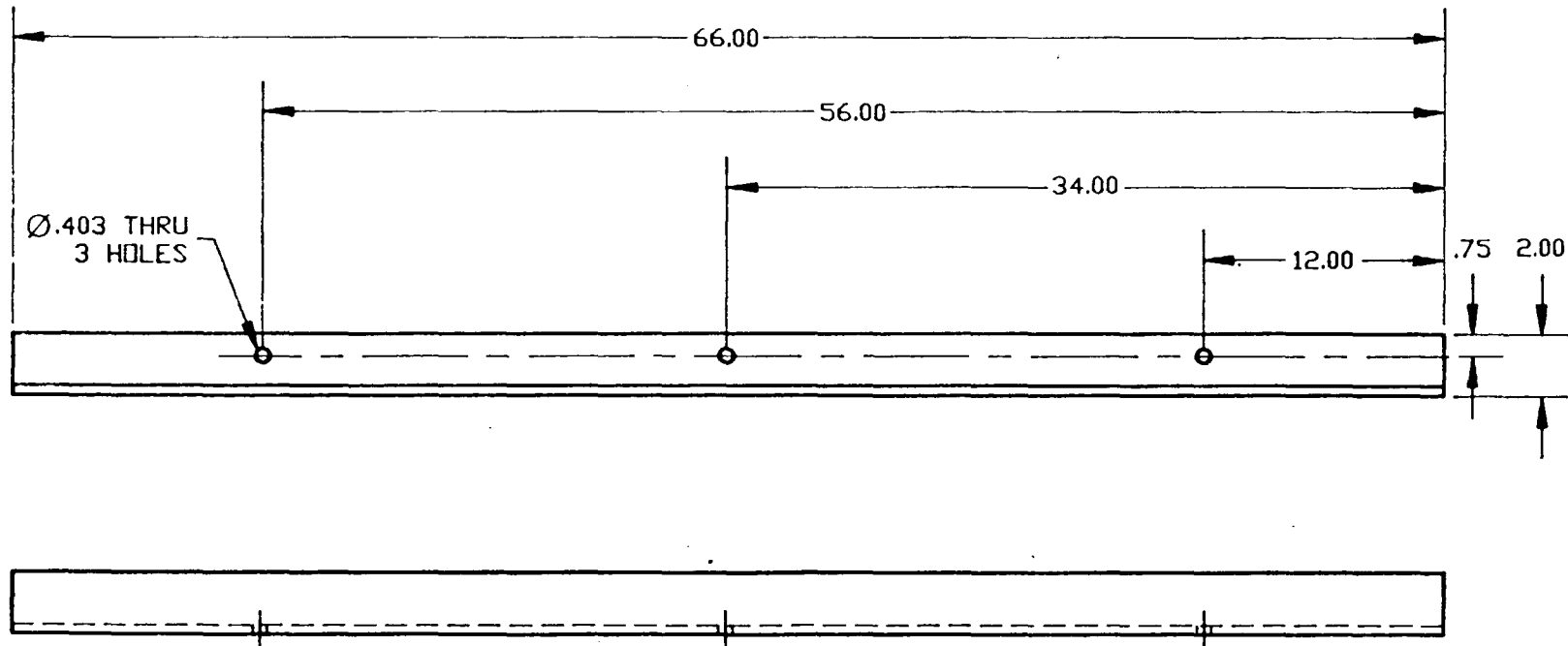

Figure 8. Tool Box Rack Assembly Part Number 20089720-6 (Sheet 6 of 11).

NOTES:

1. FABRICATE FROM:
STRUCTURAL ANGLE, 6061-T6
ALUMINUM ALLOY 2.00 X 2.00 X 0.25,
NSN 9540-00-197-9850.
2. WELD WITH 5356 ROD OR EQUAL.
3. ALL DIMENSIONS ARE IN INCHES.
4. FINISH: PRIMER, TT-P-1757
5. FINISH: WHITE, PN 17773

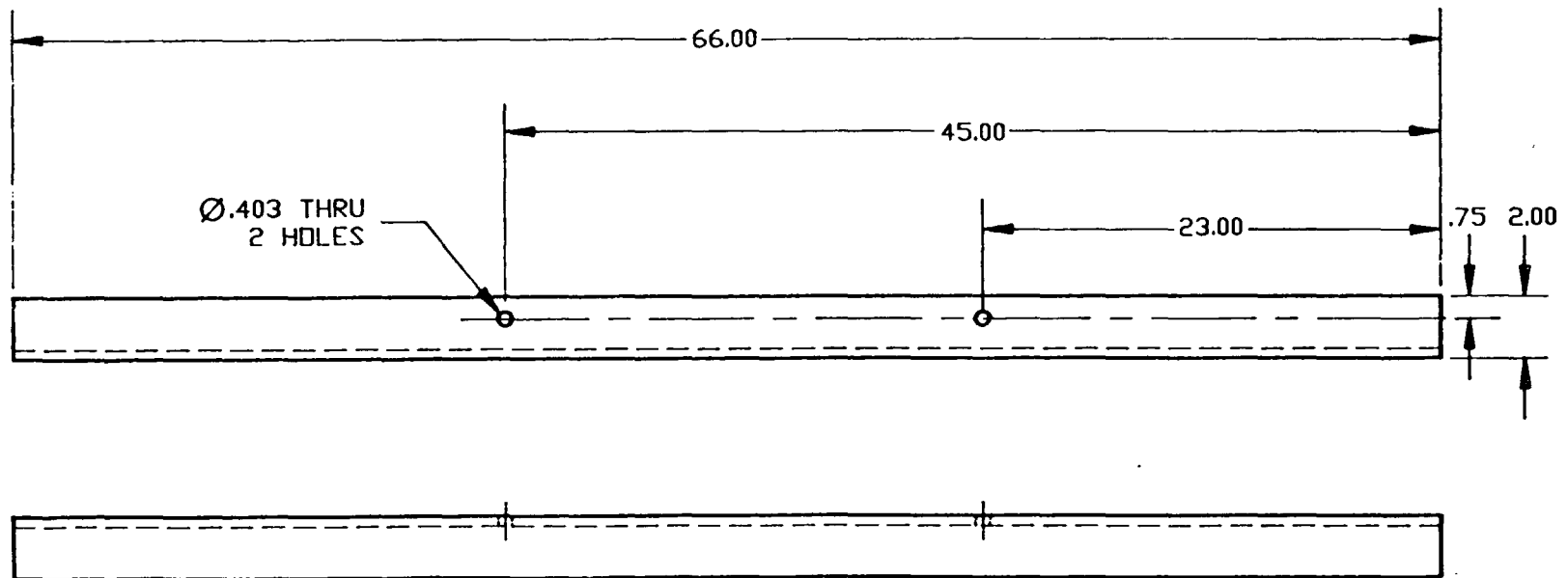

Figure 8. Tool Box Rack Assembly Part Number 20089720-7 (Sheet 7 of 11).

NOTES:

1. FABRICATE FROM:
METAL BAR, 6061-T6
ALUMINUM ALLOY, 2.00 X 0.25,
NSN 9530-00-228-9315.
2. TWO REQUIRED.
3. WELD WITH 5356 ROD OR EQUAL.
4. DIMENSIONS ARE IN INCHES.
5. FINISH: PRIMER, TT-P-1757
6. FINISH: WHITE, PN 1773

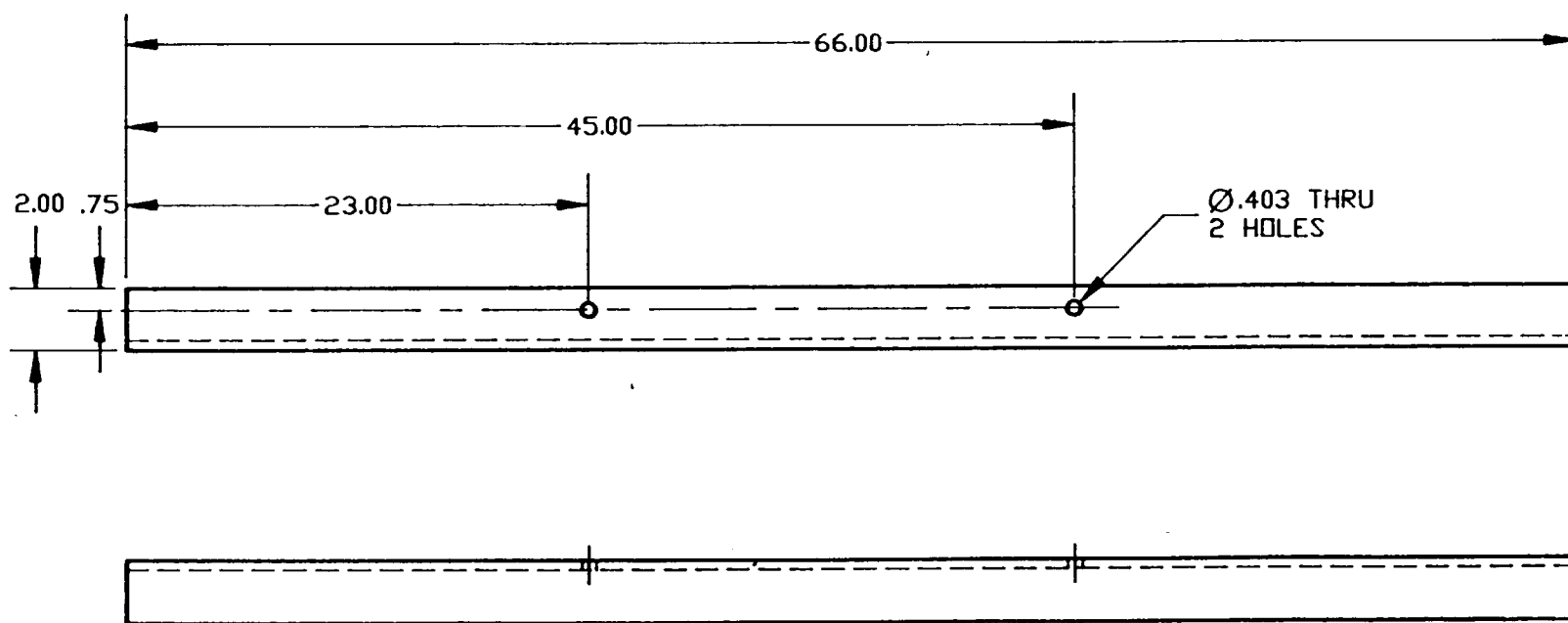

Figure 8. Tool Box Rack Assembly Part Number 20089720-8 (Sheet 8 of 11).

NOTES:

1. FABRICATE FROM:
METAL BAR, 6061-T6
ALUMINUM ALLOY, 2.00 X 0.25,
NSN 9530-00-228-9315.
2. THREE REQUIRED.
3. ALL DIMENSIONS ARE IN INCHES.
4. FINISH: PRIMER, TT-P-1757
5. FINISH: WHITE, PN 17773

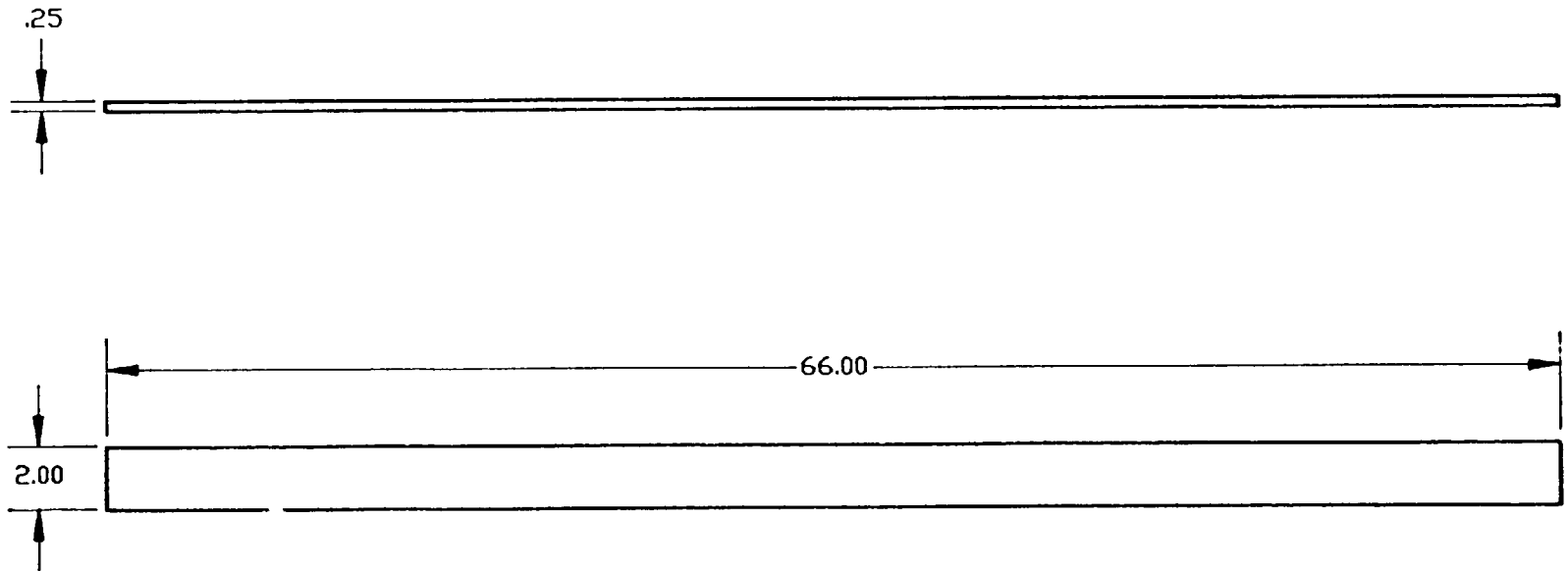

Figure 8. Tool Box Rack Assembly Part Number 20089720-9 (Sheet 9 of 11).

NOTES:

1. FABRICATE FROM:
METAL BAR, 6061-T6
ALUMINUM ALLOY, 4.00 X 0.25
NSN 9530-00-228-9316
2. THREE REQUIRED.
3. WELD WITH 5356 ROD OR EQUAL.
4. ALL DIMENSIONS ARE IN INCHES.
5. FINISH: PRIMER, TT-P-1757
6. FINISH: WHITE, PN 17773

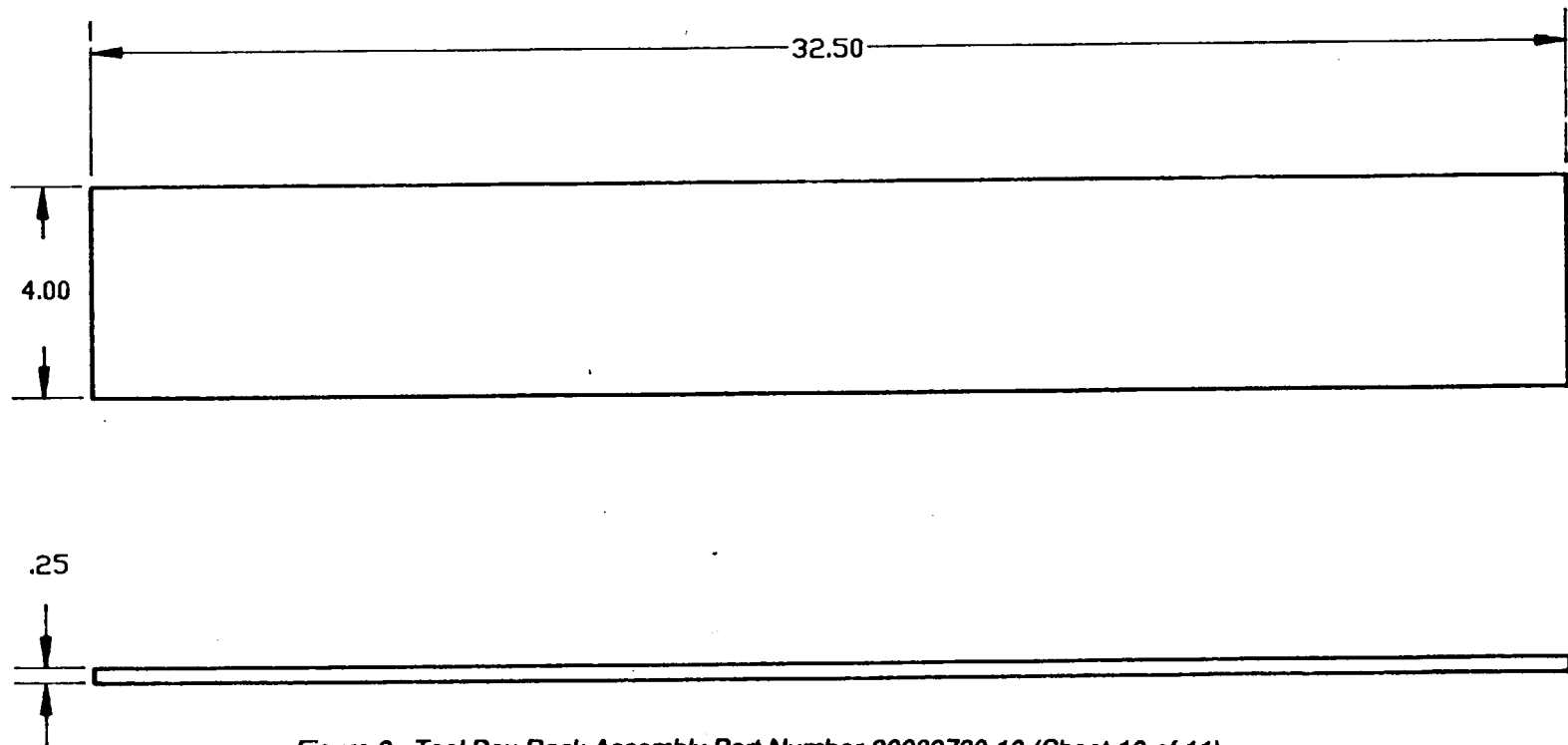

Figure 8. Tool Box Rack Assembly Part Number 20089720-10 (Sheet 10 of 11).

NOTES:

1. FABRICATE FROM:
METAL BAR, 6061-T6
ALUMINUM ALLOY, 4.00 X 0.25
NSN 9530-00-228-9316
2. THREE REQUIRED.
3. ALL DIMENSIONS ARE IN INCHES.
4. FINISH: PRIMER, TT-P-1757
5. FINISH: WHITE, PN 17773

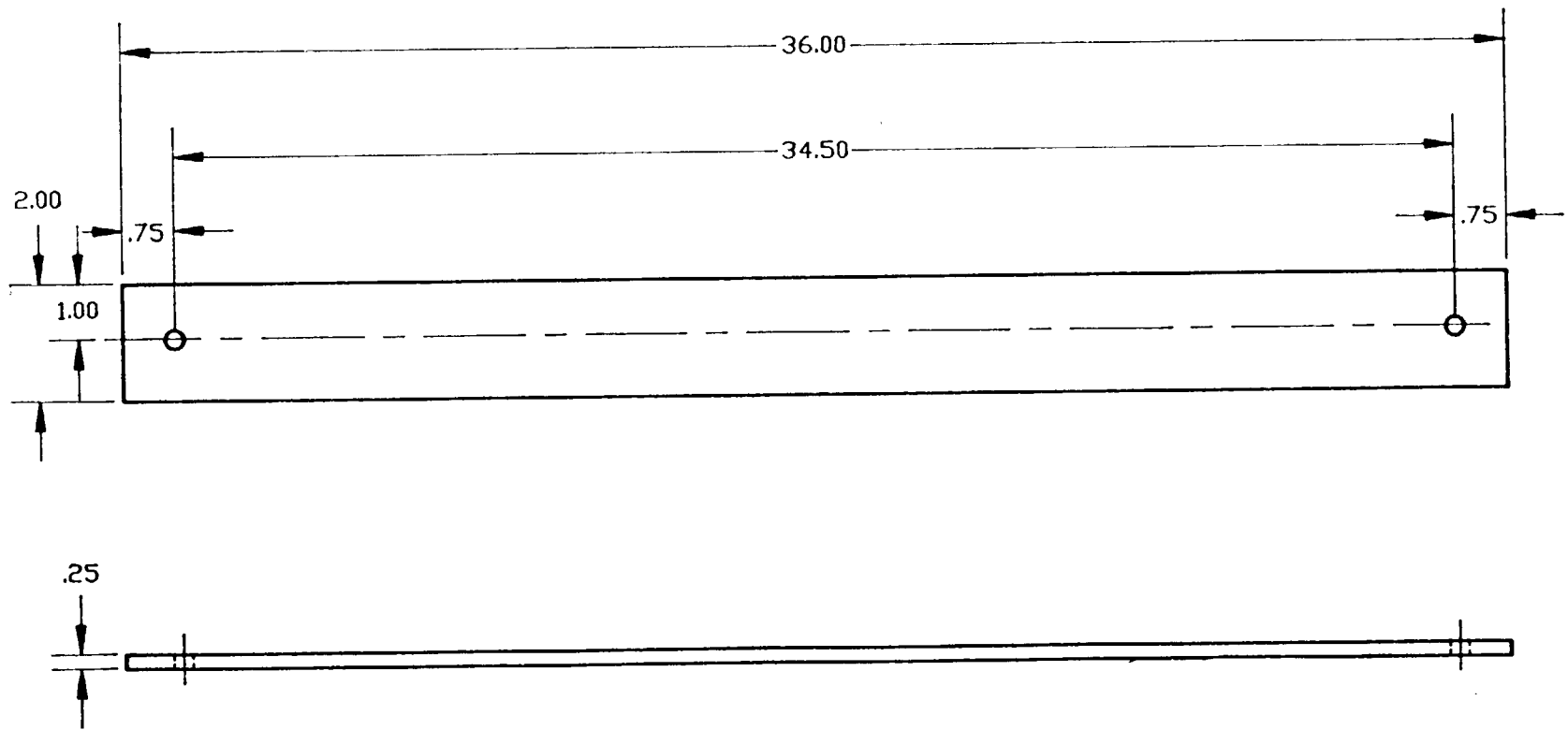

Figure 8. Tool Box Rack Assembly Part Number 20089720-11 (Sheet 11 of 11).

NOTES:

1. FABRICATE FROM:
STRUCTURAL ANGLE, 6061-T6
ALUMINUM ALLOY 2.00 X 2.00 X 0.25,
NSN 9540-00-197-9850.
2. TWO REQUIRED.
3. WELD WITH 5356 ROD OR EQUAL.
4. ALL DIMENSIONS ARE IN INCHES.
5. FINISH: PRIMER, TT-P-1757
6. FINISH: GRAY, PN 16187

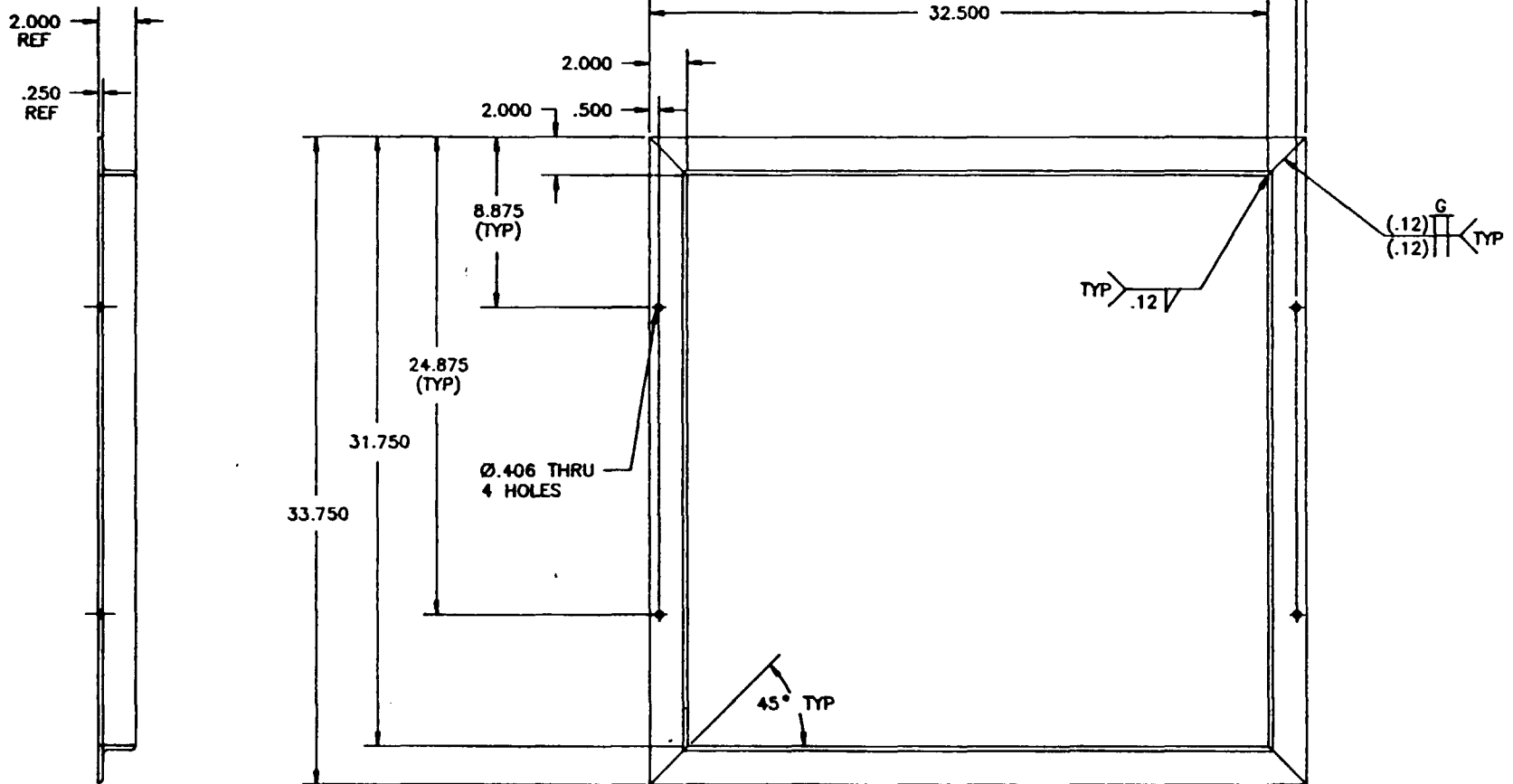
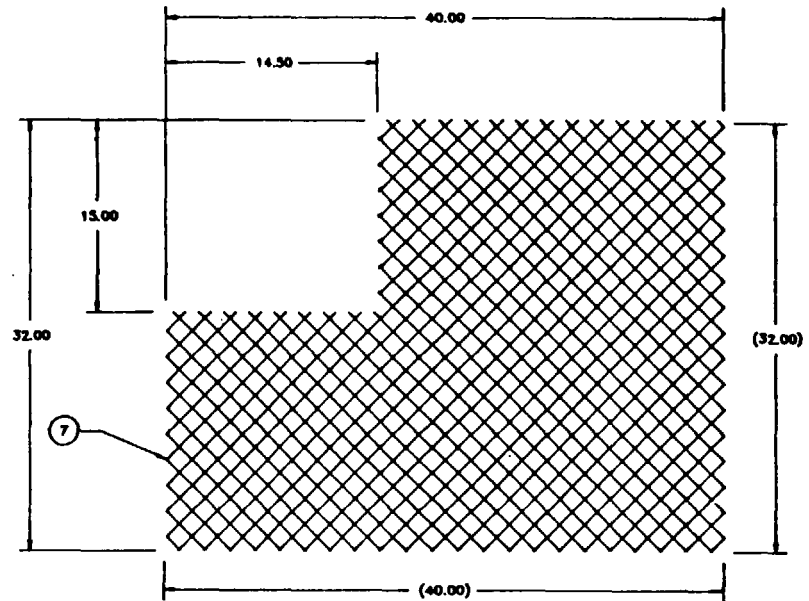
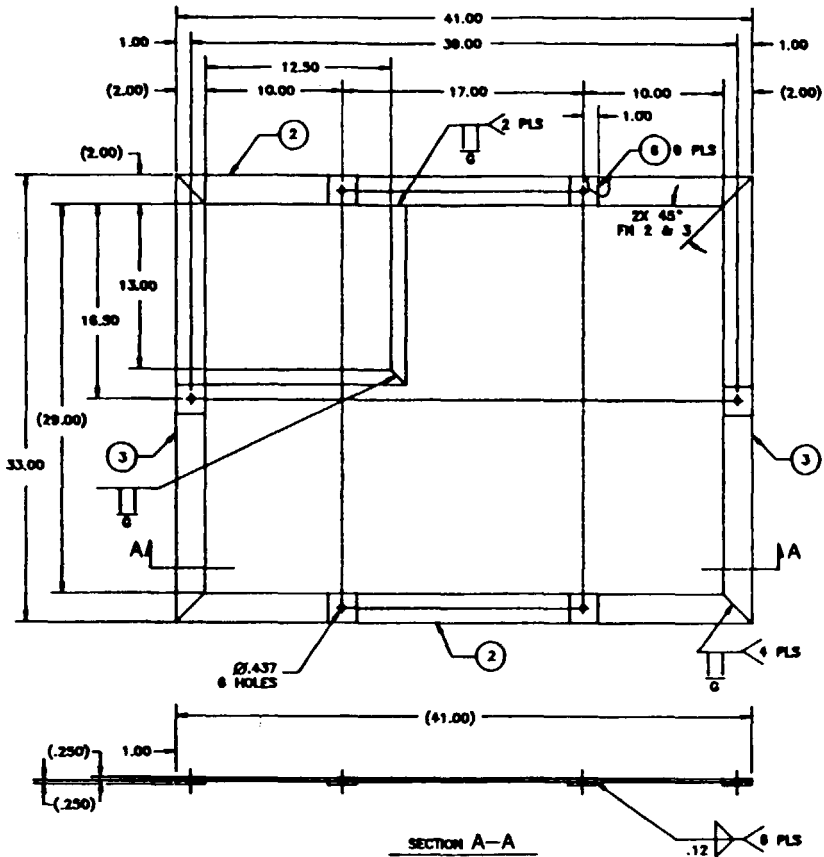

Figure 9. ECU Frame Assembly Part Number 20089711.



NOTES:

1. FABRICATE FROM:

**A. METAL BAR, 6061-T6
ALUMINUM ALLOY, 2.00 X 0.25
NSN 9530-00-228-9315**

**B. METAL BAR, 6061-T6
ALUMINUM ALLOY, 1.25 X 0.25
NSN 9530-00-237-0721**

C. EXPANDED ALUMINUM SHEET, 5055-H-34

2. TWO REQUIRED.

3. WELD WITH 5356 ROD OR EQUAL.

4. ALL DIMENSIONS ARE IN INCHES.

5. FINISH: PRIMER, TT-P-1757.

6. FINISH: WHITE, PN 17773.

Figure 10. ECU Security Screen Part Number 20089727.

APPENDIX G
TORQUE LIMITS

Bolt Size	Tension Loading
1/4-28	50-70 inch pounds
5/16-24	100-140 inch pounds
3/8-24	160-190 inch pounds

The above torque loads may be used on all cadmium-plated fine thread bolts which have approximately equal number of threads and equal face bearing areas. Size refers to bolt shank diameter or inside diameter of nut and thread indicates number of threads per inch.

ALPHABETICAL INDEX

Subject	Paragraph No.
A	
Allocation Chart, Maintenance (MAC), Column Explanation	
MAC, Section II	B-3
Remarks, Section IV	B-5
Tools and Test Equip. Requirements, Section III	B 4
Functions, Maintenance	B-2
B	
Basic Issue Items	
Column Explanation	C-1
Book Rack	
Inspect	3-19
Repair	3-20
Replace	3-21
C	
Cabinet	
Positioning for Operation	2-4.e
Positioning for Transport	2-10.b
Cable, Power, Connection to	
Power Distribution Panel.	2-3.d
Shelter	2-3.c
Cable, Counterbalance	
Removing	2-2.d
Installing	2-13.a
Capabilities	1-6.b
Characteristics	1-6.a
Chart, Maintenance Allocation (MAC), Column Explanation	
MAC, Section II	B-3
Remarks, Section IV	B-5
Tools and Test Equip. Requirements, Section III	B-4
Functions, Maintenance	B-2
Components, Location and Description of Major Ones	1-7
Components of End Item	C-1
Compressed Air	
Connecting.	2-5a
Disconnecting.	2-9.b
Counterbalance Cable	
Removing	2-2.d
Installing	2-13.a

Subject

Paragraph No.

D

Destruction of Army Materiel to Prevent Enemy Use	1-4
Disconnecting Shop Utilities	2-9
Compressed Air	2-9.b
Water Supply	2-9.a

E

ECU Shelves	
Closing	2-10.e
Lowering Procedures	2-4.a
ECUs	
Connecting Power	2-4.b
Disconnecting Power	2-10.d
Positioning for Operation	2-4.a
Positioning for Transport	2-10.e
Installing Support Frames	2-10.c
Electric Power	2-3
Connecting Power Cable to Power Distribution Panel	2-3.d
Connecting Power Cable to Shelter	2-3.c
Connecting Power Distribution Panel to Power Source	2-3.b
External Grounding of Shop	2-3a
Power ON at Shelter	2-3.e
Equipment, Unpacked, Checking	3-6
Equipment Improvement Recommendations, Reporting	1-3
Equipment, Shop, Positioning for Operation.	2-4
Cabinets	2-4.e
ECUs	2-4.a
Stool	2-4.f
Support Frames, ECU, Storing	2-4.d
Equipment Shop, Portioning for Transport	2-10
Cabinets	2-10.b
ECU's	2-10.e
Stool	2-10.a
Support Frames, ECU, Installing	2-10.c
Expendable/Durable Supplies and Materials List	
Column Explanation	D-3

F

Features	1-6
Fire Extinguisher Mounting - Inspect	3-10
Fire Extinguisher - Removal/Installation	3-9
Fixed Equipment Components - Removal/Installation	3-23
Floor Insert Fasteners and Plugs - Inspect	3-22
Forms, Maintenance	1-2

Subject	Paragraph No.
G	
Ground Rod/Strap - Inspect	3-18
Grounding, External, Shop	2-4.a
H	
Hardware	
Storage	2-7
Recover and Inspection	2-9
I	
Insert Fasteners and Bolts - Inspect	3-7
Insert Fasteners - Replace	3-8
Instructions, Maintenance	
Air Feed Thru Connector - Inspect	3-16
Air Feed Thru Connector - Replace	3-17
Book Rack - Inspect	3-19
Book Rack - Repair	3-20
Book Rack - Replace	3-21
Fasteners - Inspect	3-7
Fire Extinguisher Mounting - Inspect	3-10
Fire Extinguisher - Removal/Installation	3-9
Fire Equipment/Components - Removal/Installation	3-23
Floor Plugs - Inspect	3-22
Ground Rod/Strap - Inspect	3-18
Inserts-Replace	3-8
Water Feed Thru Connector - Inspect	3-14
Water Feed Thru Connector - Replace	3-15
Water/Oil Separator Fittings and Air Hose - Inspect	3-12
Water/Oil Separator Fittings and Air Hose - Replace	3-13
Water/Oil Separator Mounting - Inspect	3-11
Instructions, Supplemental, Expansion	2-2.c
L	
Level, Checking Shelter	2-7
Location and Description of Major Components	1-7
Lowering procedures, ECU Shelves	2-4
M	
Maintenance Allocation Chart (MAC) Column Explanation	
MAC, Section II	B-3
Remarks, Section IV	B-5
Tools and Test Equip. Requirements, Section III	B-4
Functions, Maintenance	B-2

Subject	Paragraph No.
Maintenance Instructions	
Air Feed Thru Connector - Inspect	3-16
Air Feed Thru Connector- Replace	3-17
Book Rack - Inspect	3-19
Book Rack - Repair	3-20
Book Rack - Replace	3-21
Fasteners -Inspect.....	3-7
Fire Extinguisher Mounting - Inspect	3-4
Fire Extinguisher - Removal/Installation	3-9
Fixed Equipment/Components - Removal/Installation	3-23
Floor Plugs - Inspect	3-22
Ground Rod/Strap - Inspect	3-18
Inserts - Replace.....	3-8
Water Feed Thru Connector - Inspect	3-14
Water Feed Thru Connector-Replace	3-15
Water/Oil Separator Fittings and Air Hose - Inspect	3-12
Water/Oil Separator Fittings and Air Hose - Replace	3-13
Water/Oil Separator Mounting-Inspect.....	3-11
Manufactured Items, Illustrated List	
Introduction	F-2
Scope	F-1
Manufactured Items Part Number Index	F-3

N

National Stock Number Index	Appendix D
-----------------------------------	------------

P

Part Number Index	Appendix D
Power Distribution Panel, Connecting to Power Source	2-3.b
Power, Electric	2-3
Connecting Power Cable to Power Distribution Panel	2-3.d
Connecting Power Cable to Shelter	2-3.c
Connection Power Distribution Panel to Power Source	2-3.b
External Grounding of Shop	2-3.a
Power ON at Shelter	2-3.e
Power Shutdown	2-11
Cable Disconnection	2-11.c
Circuit Breaker Panel	2-11.a
Preparation for Storage and Shipment	1-5

R

Records, Maintenance	1-2
References	
Dictionaries	A-1
Logistics and Storage	A-3
Maintenance	A-4
Other Publications	A-5
Publication Indexes	A-2
Repair	
Procedures	3-5
Parts	3-4

Subject	Paragraph No.
Repair Parts and Special Tools List	
Column Explanation	D-3
National Stock Number and Part Number List	Appendix D
Reports, Maintenance	1-2
Rotor Shop Characteristics	1-6
Rotor Shop, Expansion	2-2
Counterbalance Cable Removal	2-2.d
Supplemental Instructions	2-2.c
Rotor Shop, Placement	2-1

S

Shelter, Closing	2-13
Shelves, ECU	
Closing	2-10.e
Lowering Procedures	2-4a
Shipment/Storage, Preparation	1-5
Shop Equipment, Positioning for Operation	2-4
Cabinet	2-4.e
E C U ' s	2-4.a
Stool	2-4.f
Support Frames, ECU, Storing	2-4.d
Shop Equipment, Positioning for Transport	2-10
Cabinets	2-10.b
ECU's	2-10.e
Stool	2-10.a
Support Frames, ECU, Installing	2-10.c
Special Brackets and Fabricated Components - Book Rack Mounting	
Repair	3-19
Replace	3-20
Replace	3-21
Stool	
Positioning for Operation	2-4.e
Positioning for Transport	2-10.a
Supplies and Materials List Expendable/Durable	
Column Explanation	E-3
General	E-2
Scope	E-1
Support Frames, ECU	
Installing	2-10.d
Storing	2-4.d

T

Tools and Equipment Common	3-1
Tools and Equipment Special	3-3
Torque Limits	Appendix G
Torque Values	3-2
Transport, Position Shop Equipment for	2-10
Cabinet	2-10.b
ECU's	2-10.e
Stool	2-10.a
Support Frames, ECU, Installing	2-10.c

Subject

Paragraph No.

U

Utilities

Connecting Compressed Air	2-6.a
Connecting Water Supply	2-5.b
Disconnecting Compressed Air	2-9.b
Disconnecting Water Supply	2-9.a

W

Water Feed Thru Connector	
Inspect	3-14
Replace	3-15
Water/Oil Separator	
Fittings and Air Hose - Inspect	3-12
Fittings and Air Hose - Replace	3-13
Mounting - Inspect	3-11
Water Supply Connection	2-5.b
Water Supply, Disconnection	2-9.a

By Order of the Secretary of the Army:

Official

CARL E. VUONO
General, United States Army
Chief of Staff

PATRICIA P. HICKERSON
Colonel, United States Army
The Adjutant General

DISTRIBUTION:

To be distributed in accordance with DA Form 12-31-E, block no. 3148, -10 & CL and AVIM maintenance requirements for TM 1-4920-451-13&P.

RECOMMENDED CHANGES TO EQUIPMENT TECHNICAL PUBLICATIONS



THEN... JOT DOWN THE DOPE ABOUT IT ON THIS FORM. CAREFULLY TEAR IT OUT. FOLD IT AND DROP IT IN THE MAIL!

SOMETHING WRONG WITH THIS PUBLICATION?

FROM: (PRINT YOUR UNIT'S COMPLETE ADDRESS)

PFC JOHN DOE
COA, 3d ENGINEER BN
FT. LEONARDWOOD, MO 63108

DATE SENT

PUBLICATION NUMBER

PUBLICATION DATE

PUBLICATION TITLE

BE EXACT. PIN-POINT WHERE IT IS

PAGE NO

PARA-GRAPH

FIGURE NO

TABLE NO

6

2-1
a

IN THIS SPACE TELL WHAT IS WRONG AND WHAT SHOULD BE DONE ABOUT IT:

In line 6 of paragraph 2-1a the manual states the engine has 6 Cylinders. The engine on my set only has 4 Cylinders. Change the manual to show 4 Cylinders.

B1

4-3

Callout 16 on figure 4-3 is pointing at a bolt. In key to figure 4-3, item 16 is called a shim - Please Correct one or the other.

125

line 20

I ordered a gasket, item 19 on figure B-16 by NSN 2 910-00-762-3001. I got a gasket but it doesn't fit. Supply says I got what I ordered, so the NSN is wrong. Please give me a good NSN

PRINTED NAME, GRADE OR TITLE, AND TELEPHONE NUMBER

JOHN DOE, PFC (268) 317-7111

SIGN HERE

JOHN DOE

DA FORM 2028-2
1 JUL 79

PREVIOUS EDITIONS ARE OBSOLETE.

DRSTS-M Overprint 1, 1 Nov 80

PS--IF YOUR OUTFIT WANTS TO KNOW ABOUT YOUR RECOMMENDATION MAKE A CARBON COPY OF THIS AND GIVE IT TO YOUR HEADQUARTERS

TEAR ALONG F. ITED LINE

FILL IN YOUR
UNIT'S ADDRESS

FOLD BACK

DEPARTMENT OF THE ARMY

OFFICIAL BUSINESS

COMMANDER
U S ARMY AVIATION SYSTEMS COMMAND
ATTN: AMSAV-MC
4300 GOODFELLOW BOULEVARD
ST. LOUIS, MO 63120-1798

TEAR ALONG
PERFORATED LINE

RECOMMENDED CHANGES TO EQUIPMENT TECHNICAL PUBLICATIONS

SOMETHING WRONG WITH THIS PUBLICATION?



THEN... JOT DOWN THE DOPE ABOUT IT ON THIS FORM. CAREFULLY TEAR IT OUT. FOLD IT AND DROP IT IN THE MAIL!

FROM: (PRINT YOUR UNIT'S COMPLETE ADDRESS)

DATE SENT

PUBLICATION NUMBER

TM 1-4920-451-13&P

PUBLICATION DATE

1 May 1991

PUBLICATION TITLE Operator's & AVIM

Manual Including RPSTL for Shop Set
Rotor, Airmobile

BE EXACT PIN-POINT WHERE IT IS

PAGE NO	PARA-GRAPH	FIGURE NO	TABLE NO

IN THIS SPACE TELL WHAT IS WRONG AND WHAT SHOULD BE DONE ABOUT IT:

PRINTED NAME GRADE OR TITLE AND TELEPHONE NUMBER

SIGN HERE

DA FORM 2028-2
1 JUL 79

PREVIOUS EDITIONS ARE OBSOLETE

PS - IF YOUR OUTFIT WANTS TO KNOW ABOUT YOUR RECOMMENDATION MAKE A CARBON COPY OF THIS AND GIVE IT TO YOUR HEADQUARTERS

FILL IN YOUR
UNIT'S ADDRESS

FOLD BACK

DEPARTMENT OF THE ARMY

OFFICIAL BUSINESS

COMMANDER
U S ARMY AVIATION SYSTEMS COMMAND
ATTN: AMSAV-MC
4300 GOODFELLOW BOULEVARD
ST. LOUIS, MO 63120-1798

TEAR ALONG
PERFORATED LINE

RECOMMENDED CHANGES TO EQUIPMENT TECHNICAL PUBLICATIONS



THEN... JOT DOWN THE DOPE ABOUT IT ON THIS FORM. CAREFULLY TEAR IT OUT. FOLD IT AND DROP IT IN THE MAIL.

SOMETHING WRONG WITH THIS PUBLICATION?

FROM (PRINT YOUR UNIT'S COMPLETE ADDRESS)

DATE SENT

PUBLICATION NUMBER

TM 1-4920-451-13&P

PUBLICATION DATE

1 May 1991

PUBLICATION TITLE Operator's & AVIM

Manual Including RPSTL for Shop Set Rotor, Airmobile

BE EXACT PIN-POINT WHERE IT IS

PAGE NO

PARA-GRAPH

FIGURE NO

TABLE NO

IN THIS SPACE TELL WHAT IS WRONG AND WHAT SHOULD BE DONE ABOUT IT:

PRINTED NAME GRADE OR TITLE AND TELEPHONE NUMBER

SIGN HERE

FILL IN YOUR
UNIT'S ADDRESS

FOLD BACK

DEPARTMENT OF THE ARMY

OFFICIAL BUSINESS

COMMANDER
U S ARMY AVIATION SYSTEMS COMMAND
ATTN: AMSAV-MC
4300 GOODFELLOW BOULEVARD
ST. LOUIS, MO 63120-1798

TEAR ALONG PERFORATED LINE

RECOMMENDED CHANGES TO EQUIPMENT TECHNICAL PUBLICATIONS



SOMETHING WRONG WITH THIS PUBLICATION?

THEN... JOT DOWN THE DOPE ABOUT IT ON THIS FORM. CAREFULLY TEAR IT OUT. FOLD IT AND DROP IT IN THE MAIL.

FROM: (PRINT YOUR UNIT'S COMPLETE ADDRESS)

DATE SENT

PUBLICATION NUMBER TM 1-4920-451-13&P	PUBLICATION DATE 1 May 1991	PUBLICATION TITLE Operator's & AVIM Manual Including RPSTL for Shop Set Rotor, Airmobile
--	--------------------------------	--

BE EXACT PIN-POINT WHERE IT IS				IN THIS SPACE TELL WHAT IS WRONG AND WHAT SHOULD BE DONE ABOUT IT:
PAGE NO	PARA-GRAPH	FIGURE NO	TABLE NO	

PRINTED NAME GRADE OR TITLE AND TELEPHONE NUMBER	SIGN HERE
--	-----------

FILL IN YOUR
UNIT'S ADDRESS

FOLD BACK

DEPARTMENT OF THE ARMY

OFFICIAL BUSINESS

COMMANDER
U S ARMY AVIATION SYSTEMS COMMAND
ATTN:AMSAV-MC
4300 GOODFELLOW BOULEVARD
ST. LOUIS, MO 63120-1798

TEAR ALONG PERFORATED LINE

The Metric System and Equivalents

Linear Measure

1 centimeter = 10 millimeters = .39 inch
 1 decimeter = 10 centimeters = 3.94 inches
 1 meter = 10 decimeters = 39.37 inches
 1 dekameter = 10 meters = 32.8 feet
 1 hectometer = 10 dekameters = 328.08 feet
 1 kilometer = 10 hectometers = 3,280.8 feet

Weights

1 centigram = 10 milligrams = .15 grain
 1 decigram = 10 centigrams = 1.54 grains
 1 gram = 10 decigrams = .035 ounce
 1 dekagram = 10 grams = .35 ounce
 1 hectogram = 10 dekagrams = 3.52 ounces
 1 kilogram = 10 hectograms = 2.2 pounds
 1 quintal = 100 kilograms = 220.46 pounds
 1 metric ton = 10 quintals = 1.1 short tons

Liquid Measure

1 centiliter = 10 milliliters = .34 fl. ounce
 1 deciliter = 10 centiliters = 3.38 fl. ounces
 1 liter = 10 deciliters = 33.81 fl. ounces
 1 dekaliter = 10 liters = 2.64 gallons
 1 hectoliter = 10 dekaliters = 26.42 gallons
 1 kiloliter = 10 hectoliters = 264.18 gallons

Square Measure

1 sq. centimeter = 100 sq. millimeters = .155 sq. inch
 1 sq. decimeter = 100 sq. centimeters = 15.5 sq. inches
 1 sq. meter (centare) = 100 sq. decimeters = 10.76 sq. feet
 1 sq. dekameter (are) = 100 sq. meters = 1,076.4 sq. feet
 1 sq. hectometer (hectare) = 100 sq. dekameters = 2.47 acres
 1 sq. kilometer = 100 sq. hectometers = .386 sq. mile

Cubic Measure

1 cu. centimeter = 1000 cu. millimeters = .06 cu. inch
 1 cu. decimeter = 1000 cu. centimeters = 61.02 cu. inches
 1 cu. meter = 1000 cu. decimeters = 35.31 cu. feet

Approximate Conversion Factors

To change	To	Multiply by	To change	To	Multiply by
inches	centimeters	2.540	ounce-inches	newton-meters	.007062
feet	meters	.305	centimeters	inches	.394
yards	meters	.914	meters	feet	3.280
miles	kilometers	1.609	meters	yards	1.094
square inches	square centimeters	6.451	kilometers	miles	.621
square feet	square meters	.093	square centimeters	square inches	.155
square yards	square meters	.836	square meters	square feet	10.764
square miles	square kilometers	2.590	square meters	square yards	1.196
acres	square hectometers	.405	square kilometers	square miles	.386
cubic feet	cubic meters	.028	square hectometers	acres	2.471
cubic yards	cubic meters	.765	cubic meters	cubic feet	35.315
fluid ounces	milliliters	29.573	cubic meters	cubic yards	1.308
pints	liters	.473	milliliters	fluid ounces	.034
quarts	liters	.946	liters	pints	2.113
gallons	liters	3.785	liters	quarts	1.057
ounces	grams	28.349	liters	gallons	.264
pounds	kilograms	.454	grams	ounces	.035
short tons	metric tons	.907	kilograms	pounds	2.205
pound-feet	newton-meters	1.356	metric tons	short tons	1.102
pound-inches	newton-meters	.11296			

Temperature (Exact)

°F	Fahrenheit	5/9 (after	Celsius	°C
	temperature	subtracting 32)	temperature	

